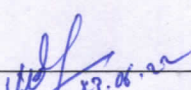
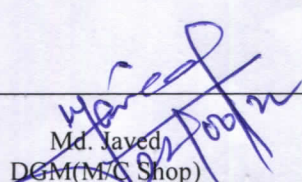
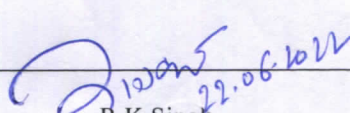

**PARTING PLANE MACHINING OF IPI CASING (LH)****i) PRE QUALIFICATION REQUIREMENT**

S.No.	BHEL Requirements	Vendor's Confirmation
1	Only those vendors should quote who have past experience of machining of similar jobs having max. height $\geq 2500$ mm and weight $\geq 20$ MT to the full satisfaction of the customer. (Both criteria may be fulfilled through one or more jobs)	Vendor to Confirm and submit detail (including copy of P.O. & Inspection/Acceptance report along with the offer)
2	Vendor to provide specification of the suitable machine on which machining is planned	Vendor to submit detail
3	Vendor should have material handling capacity $\geq 34$ MT	Vendor to Confirm and submit detail

**ii) TECHNICAL REQUIREMENT**

S.No.	BHEL Requirement	Vendor's Confirmation
1	Marking and Machining as per drawing no. 0-106-02-56901/M6:Rev-A	Vendor to confirm
2	Vendor to arrange all tools & instruments required for machining of the job	Vendor to confirm
3	BHEL reserves the right to visit vendor for stage inspection during job machining to assess the progress and technical aspects and further processing shall be done accordingly.	Vendor to confirm
4	Final Inspection of the machined job may be carried out by BHEL at vendor's works before despatch	Vendor to confirm
5	Delivery requirement: 4 weeks/pc from the date of lifting	Vendor to confirm
6	Identification details on the casting to be maintained	Vendor to confirm
7	Vendor to submit following with the offer:- a) Details of the Organization b) Details of the machine tools and other facilities installed in the company	Vendor to submit
8	Vendor to submit Filled Supplier Registration Form along with Requisite Documents to SDC Cell in MM Deptt. of CFFP, BHEL, Haridwar. If already registered at CFFP or any other unit of BHEL, then Vendor code may be furnished.	Vendor to submit
9	Vendor may plan a visit to CFFP for technical discussion.	Vendor to Note
10	BHEL team may visit vendor's works for facility/capacity verification.	Vendor to Accept
11	Job shall be offered to vendor with parting plane machined. Therefore, parting plane machining is not required from vendor.	Vendor to Note

 Vikalp Bibhuti Dy. Manager (M/C Shop)	 Md. Javed DGM(M/C Shop)	 R.K.Singh AGM (M/C Shop)
---	---	--

Indent No. : 20220072

9W/L06901/M6  
0-106-02-56901-0  
DRAWING NUMBER

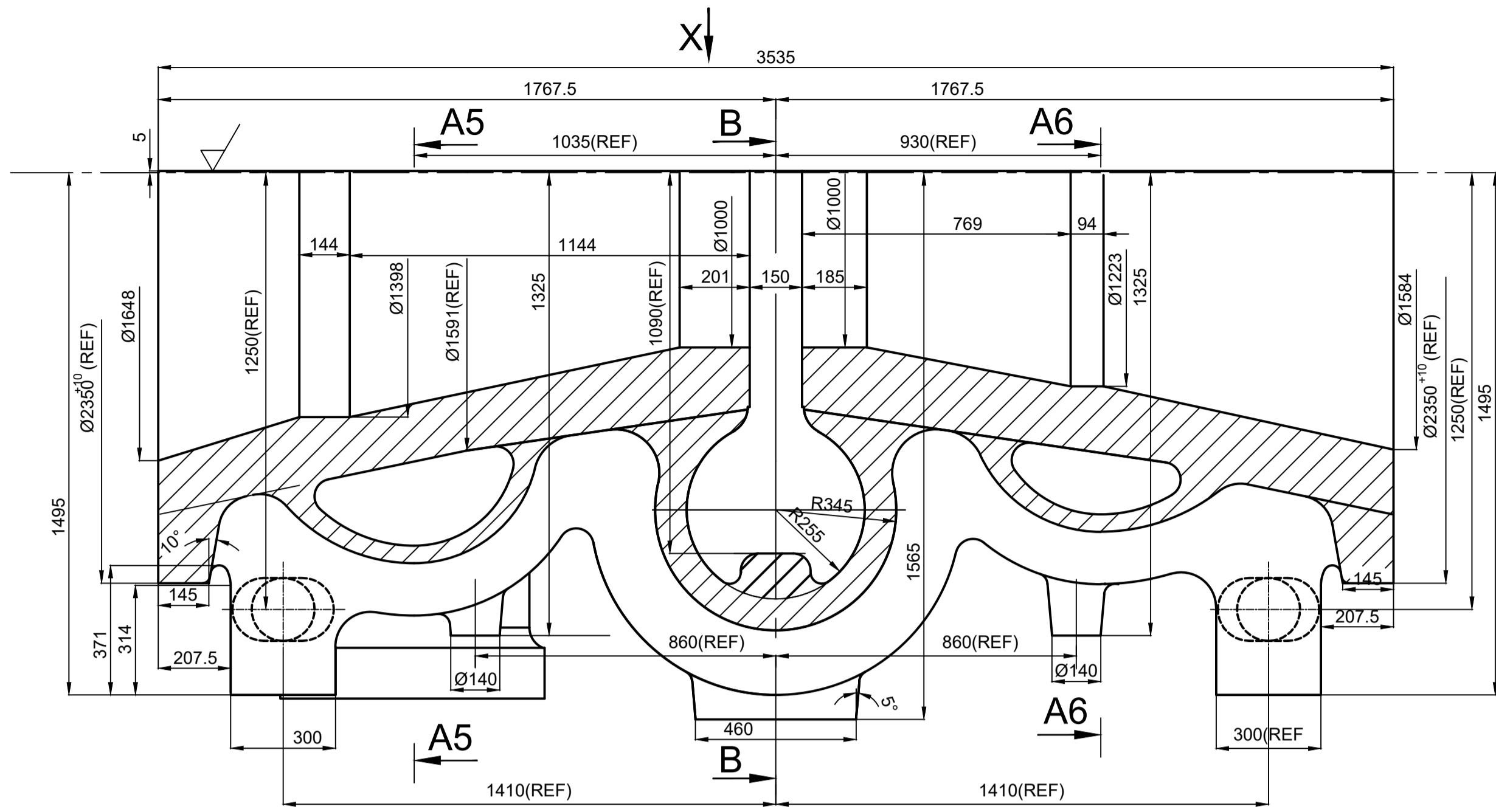

SECTION A-A

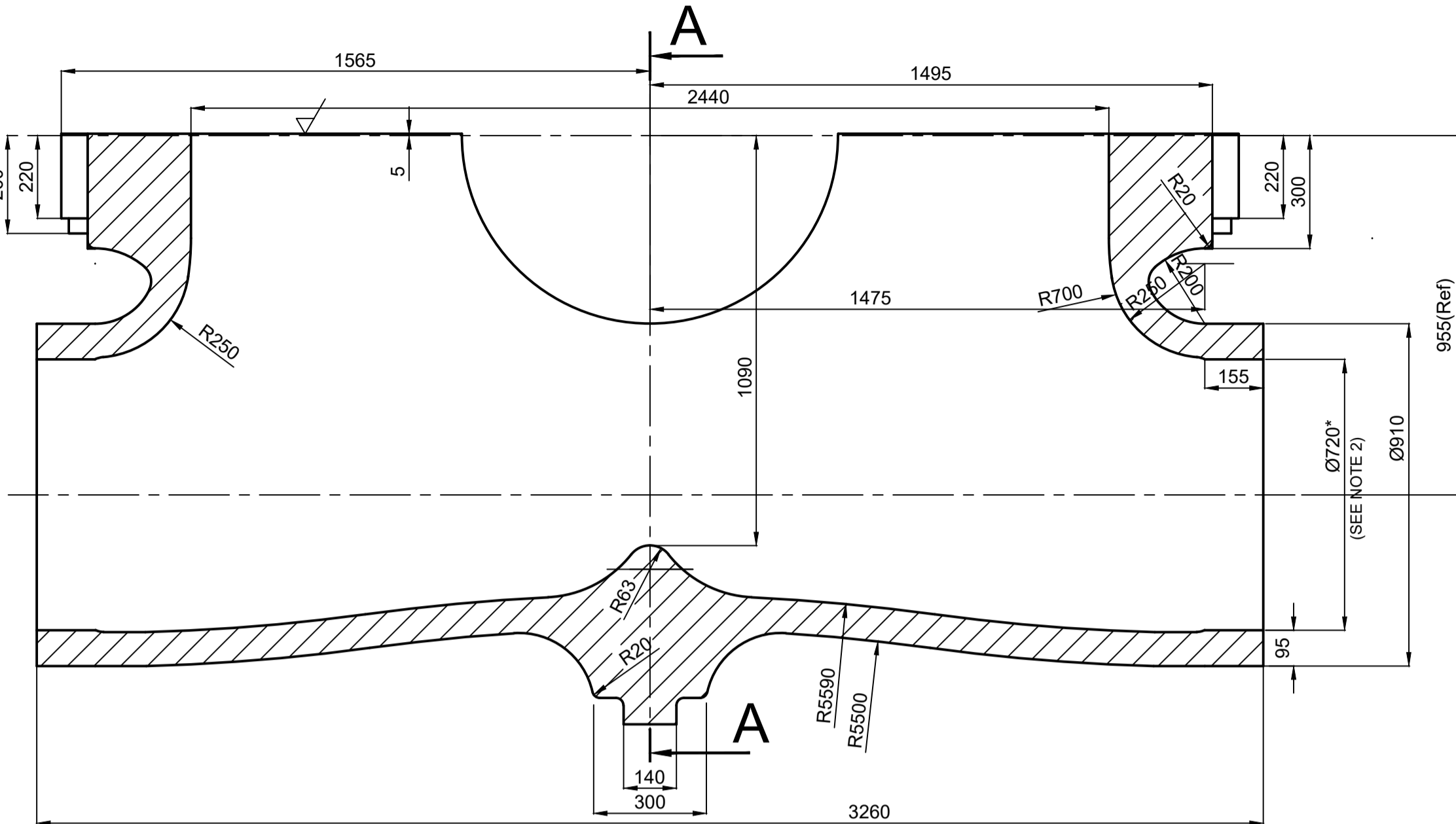

SECTION B-B

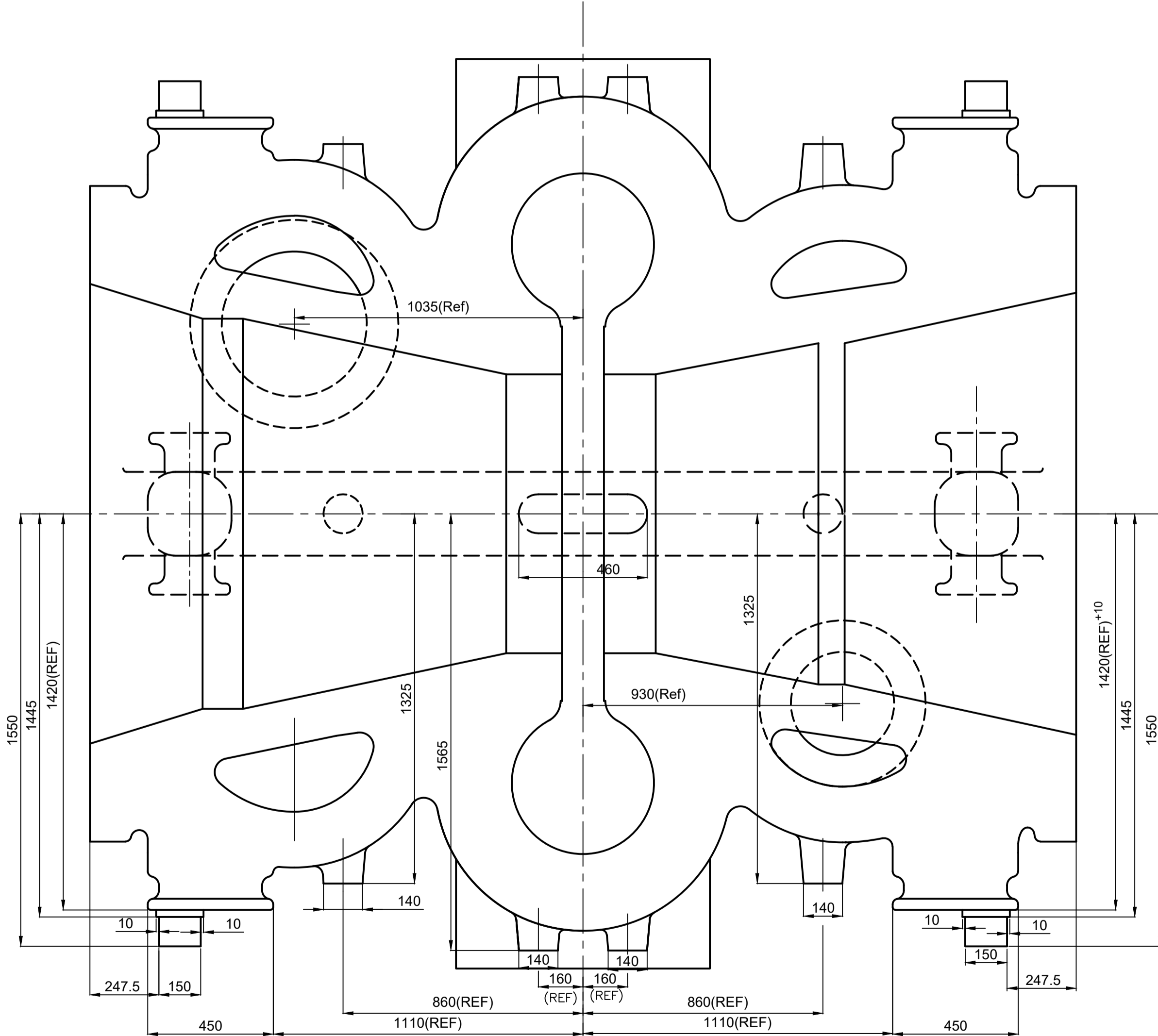

VIEW-X

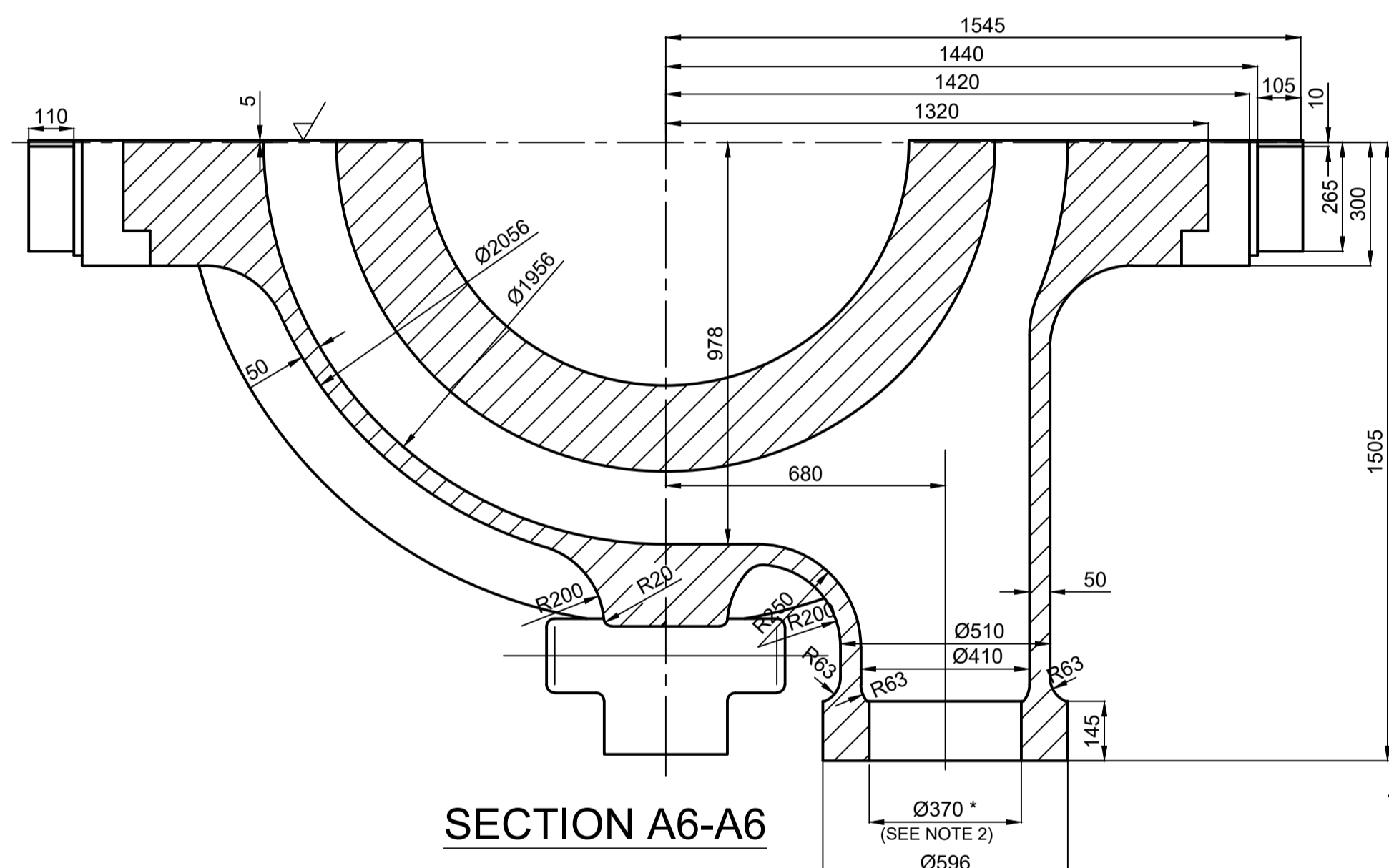

SECTION A6-A6

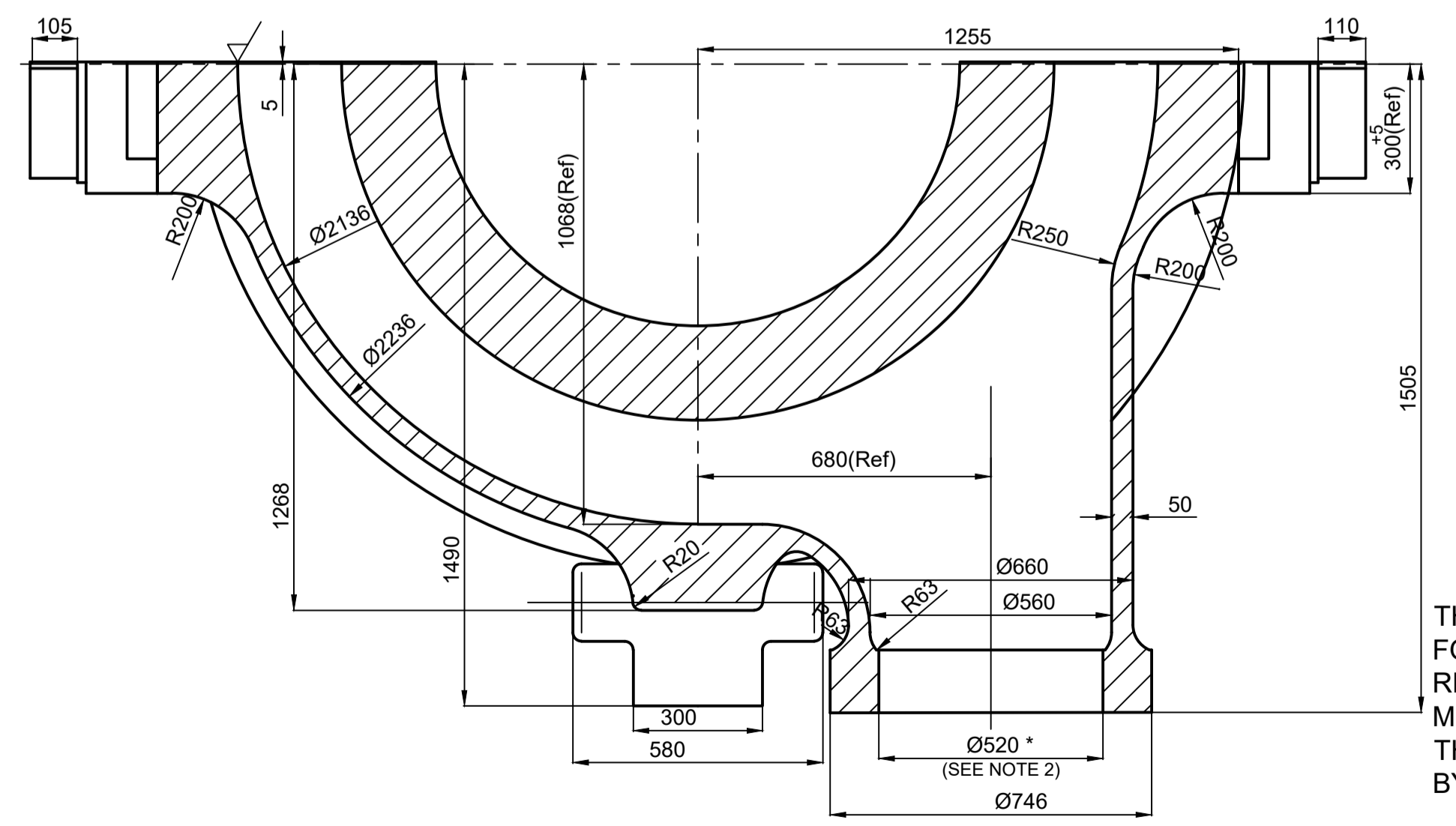

SECTION A5-A5

- NOTE**
- CASTING TO BE ROUGH MACHINED ALL OVER TO DRAWING DIMENSIONS TO THE SURFACE FINISH OF 12.5 MICRONS AND TO THE TOLERANCE OF +2 ON OD AND HT, -2 ON ID, UNLESS OTHERWISE STATED. -0 -0
  - THE \* MARKED DIMENSIONS TO BE MACHINED FURTHER TO ACHIEVE DIMENSIONS AS DETAILED BELOW AFTER UPGRADATION WORK OF THE CASTING IN FOUNDRY.
- | SL NO. | * MARKED DIM | DIM TO BE ACHIEVED |
|--------|--------------|--------------------|
| I.     | Ø720         | Ø730               |
| II.    | Ø370         | Ø380               |
| III.   | Ø520         | Ø530               |
- THIS DRG IS ISSUED FOR THE PURPOSE OF ROUGH MACHINING ONLY. FOR ALL OTHER DETAILS PLEASE REFER COMPONENT DRG NO. 0-106-02-56901 REV 01
  - WT OF THE CASTING BEFORE MACHINING : 33900 Kgs.  
WT OF THE CASTING AFTER 1st STAGE MACHINING: 33250 Kgs.

THIS DRAWING IS ISSUED FOR MACHINING OF IP INNER CASING FOR MAITREE, KURJA & SAGARDIGI PROJECT AS PER RESPECTIVE PO. THE INTERNAL DIAMETERS HAVE BEEN MODIFIED IN LINE WITH REQUIREMENT OF CUSTOMER VIDE THEIR EMAIL DT. 2/4/2018 AND ANNEXURE DOCUMENT PROVIDED BY MTE.

**BHARAT HEAVY ELECTRICALS. LTD.**  
CENTRAL FOUNDRY FORGE PLANT  
RANIPUR HARDWAR

REV	DATE	ALTERED	ZONE	REV	DATE	ALTERED	ZONE	REV	DATE	ALTERED	ZONE	REV	DATE	ALTERED	ZONE
		CHECKED				CHECKED				CHECKED				CHECKED	

TITLE: ROUGH MACHINING DRG. FOR I.P. INNER CASING (L.H.)  
 PROJECT AND CUSTOMER NAME: 660 MW MAITREE  
 TECHNOLOGY NO: 16601D  
 DRAWING NO: 0-106-02-56901/M6  
 SHEET NO.: 1 NO. OF SHEETS: 11

### Item Description

Tender Enquiry No	FF/SC/22024/202200721
Item	IP Inner Casing LH (R/M)
Drg No	0-106-02-56901/M6: Rev-A
Quantity	2 No
Delivery Terms	4 Weeks / Pc
Before M/c weight	33900 KG
After M/c weight	33250 KG

- 1 MARK & MACHINE AS PER DLY DRG.
- 2 IDENTIFICATION NO. TO BE PUNCHED
- 3 NTPC SEAL TO BE RETAINED
- 4 SCOPE OF MACHINING- PARTING PLANE MACHINING