

# REQUEST FOR QUOTATION

	<b>BHARAT HEAVY ELECTRICALS LIMITED</b> Electronics Division PB No. 2606, Mysore Road Bangalore - 560026 INDIA	RFQ NUMBER: <b>AKSPROP003</b>	Due Date/Day: 12.05.2022 THU Time : 13:00 HRS [REDACTED]
MMI:PU:RF:003		RFQ DATE : 19.04.2022	[REDACTED]

(address for communication) :	(for all correspondence) Purchase Executive : ABHISHEK Phone : 26998102 Fax : 00918026989215 E-mail: singh.abhishek@bhel.in
-------------------------------	---

1) This RFQ is for entering into Rate contract (RC) with BHEL for the tendered item. Validity of the RC will be 1 year from the award of rate contract. Firm orders will be placed during the tenure of rate contract. Prices will remain firm till the validity of RC or till the completion of supplies against the Purchase Orders placed against this rate contract whichever is later. Please note that these quantities are projections based on the current business scenario and expected orders from customers. In the eventuality of business not coming through, BHEL is not obligated to exhaust the ordering of RC quantities.

2) Reverse Auction Clause: BHEL shall be resorting to Reverse Auction (RA) (Guidelines as available on www.bhel.com) for this tender. RA shall be conducted among all the techno-commercially qualified bidders. Price bids of all techno-commercially qualified bidders shall be opened and same shall be considered as initial bids of bidders in RA. In case any bidder(s) do(es) not participate in online Reverse Auction, their sealed envelope price bid along with applicable loading, if any, shall be considered for ranking.

SI No.	Description	Qty	Unit	Delivery qty	Delivery Date
1	TI0668103779 CAPACITOR 1.085mF 2800Vdc 300A * HSN/SAC : 8532 [REDACTED] [REDACTED] CAPACITOR 1.085mF 2800Vdc 300A [REDACTED]	2,000	NO	2,000	[REDACTED]

Total Number of Items - 1

- 1.
- 2.

NOTES: 1. This RFQ is governed by: a) INSTRUCTIONS TO BIDDERS/SELLERS and GENERAL CONDITIONS OF CONTRACT FOR PURCHASE available at <a href="http://edn.bhel.com">http://edn.bhel.com</a> (RFQ-PO Terms & Conditions) b) Any other specific Terms and Conditions mentioned. [REDACTED] [REDACTED]	For and On behalf of BHEL.  ABHISHEK Control Equipment  1 OF 1
* The HSN/SAC no mentioned against the line items in the RFQ are indicative only.	



**PREQUALIFICATION CRITERIA (PQC)  
FOR 1085 $\mu$ F RESONANT CAPACITOR  
GROUP: TRACTION ENGINEERING**

Ref: 445/PQ\_1085uFC/21

Rev. No.: 00

Page 1 of 1

COPYRIGHT AND CONFIDENTIAL  
The information on this document is the property of BHARAT HEAVY ELECTRICALS LIMITED.  
It must not be used directly or indirectly in anyway detrimental to the interest of the company.

**1.0 PRE QUALIFICATION CRITERIA (PQC)**

1. The Bidder should be Supplier of Capacitors used in Traction applications.
2. BHEL shall approach and submit credentials/details furnished by vendor with their offers to customer and await customer's decision for a maximum of one month from the date of tender opening. If approval is not received within the above period, BHEL shall treat the offer as "Not meeting" Pre-qualification criteria and offer shall be rejected.
3. It is preferred that the bidder is the manufacturer of this item. If the bidder is importing some portion of the components, then minimum value addition shall be 20%. Bidder to confirm this in the offer. Value addition less than 20% is not acceptable

**2.0 DOCUMENTS SUBMISSION**

1. Bidder to submit clause by clause compliance to complete technical specification (Technical specification no. PS4452714 Rev. No.00, dated 03-02-2021) along with copy of type test report.
2. Should possess a valid type test report, not older than five years, conducted at a NABL accredited laboratory as per relevant standards mentioned in the specification with respect to time during the bid submission.
3. Proof of supply of Power Capacitors for power electronic converters used in traction applications directly or through any agency to Indian Railways during the last 5 years to be submitted.

**3.0 REFERENCE DOCUMENTS**

- a) Purchase Specification No PS4452714, Rev. No. 00 for 1085 $\mu$ F Resonant Capacitors.

REVISION 00

APPROVED

  
AGOSH CHANDRAN R S

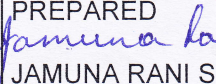
PREPARED  
  
JAMUNA RANI S

ISSUED  
TRACTION ENGG

DATE  
03.02.2021



**PURCHASE SPECIFICATION FOR  
1085 $\mu$ F RESONANT CAPACITOR  
GROUP: TRACTION ENGINEERING**

P.S NO. : PS4452714

REV. NO: 00

PAGE 01 OF 07

**REVISION HISTORY SHEET**

REV. NO	DATE	NATURE OF CHANGE	REASONS	PREPARED BY	APPROVED BY
00	03.02.2021	FIRST ISSUE	--	Jamuna Rani S	Agosh Chandran

THIS DOCUMENT IS A SPECIFICATION CUM DATA SHEET. VENDOR TO GIVE CONFIRMATIONS AND DATA AS REQUIRED AND SUBMIT THE SAME TO BHEL / EDN, BANGALORE. ANY DEVIATIONS TO THIS DOCUMENT TO BE BROUGHT OUT CLEARLY BY VENDOR.

REVISIONS 00 DT: 03.02.2021

APPROVED BY:   
Agosh Chandran R S

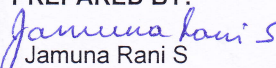
PREPARED BY:  
  
Jamuna Rani S

ISSUED BY  
TRACTION ENGG

DATE  
03.02.2021

COPYRIGHT AND CONFIDENTIAL  
The information on this document is the property of BHARAT HEAVY ELECTRICALS LIMITED.  
It must not be used directly or indirectly in anyway detrimental to the interest of the company.



**PURCHASE SPECIFICATION FOR  
1085 $\mu$ F RESONANT CAPACITOR  
GROUP: TRACTION ENGINEERING**

P.S NO. : PS4452714

REV. NO: 00

A4 – 12

PAGE 02 OF 07

**SPECIFICATION FOR 1085 $\mu$ F RESONANT CAPACITOR**

**Brief description**

A 100Hz ripple voltage arise because of the single –phase powered and DC loaded system. To reduce the 100Hz DC-link ripple voltage a series resonant filter is used. This filter comprises an inductor and a capacitor bank. The series resonant circuit serves to filter out the current at double the line frequency, and is tuned to this frequency.

This document specifies a 100Hz series resonant capacitor, used in IGBT propulsion systems. A simplified schematic of the main power scheme can be found in **Figure 1: Simplified main power scheme.**

Figure 1:

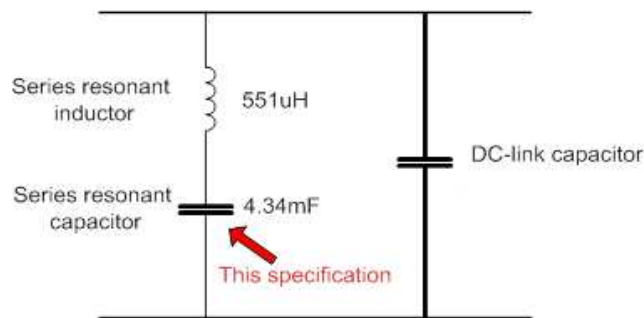

Figure 1: Simplified main power scheme

The capacitor will be fitted in the traction converter cubicle. It will be natural cooled, no forced ventilation. **The capacitor must be dry, oil filled is not allowed.**

**1. Detailed Specification**

1. Electrical Parameters	
Capacitance per Capacitor	1085 $\mu$ F +/-5% (4 capacitors in parallel)
Rated DC Voltage	2800 VDC
Maximum Voltage	3640 V
Rated Current	300 Arms 1200A for 4 capacitors in parallel
Test Voltage b/w terminals	DC 5265V/10sec
Test Voltage b/w terminals	AC 6900V/60sec
Series resistance	<0.28m $\Omega$
Tangent of Loss Angle	2*10 <sup>-4</sup>
Self-Inductance	approx. 100nH
Maximum Peak Current	25 kA
Maximum Surge Current	75 kA
Cooling	Natural Convection

COPYRIGHT AND CONFIDENTIAL  
The information on this document is the property of BHARAT HEAVY ELECTRICALS LIMITED.  
It must not be used directly or indirectly in anyway detrimental to the interest of the company.



A4 – 12

**PURCHASE SPECIFICATION FOR  
1085 $\mu$ F RESONANT CAPACITOR  
GROUP: TRACTION ENGINEERING**

P.S NO. : PS4452714

REV. NO: 00

PAGE 03 OF 07

COPYRIGHT AND CONFIDENTIAL  
The information on this document is the property of BHARAT HEAVY ELECTRICALS LIMITED.  
It must not be used directly or indirectly in anyway detrimental to the interest of the company.

**2. Technology**

<b>Dielectric</b>	Polypropylene film metallized, self-healing
<b>Filling material</b>	N <sub>2</sub> ; resin, dry

**3. Bushing**

<b>Internal thread</b>	M12
<b>Max. torque</b>	20 Nm
<b>Height</b>	73 mm
<b>Creepage distance</b>	128 mm

**4. Mechanical Parameters**

<b>Dimensions</b>	450 x 120 x 560 mm
<b>Weight</b>	40 kg
<b>Casing material</b>	Stainless steel
<b>Mounting position</b>	every position
<b>Clearance distance b/w terminals</b>	$\geq 60$ mm
<b>Clearance distance b/w terminals and case</b>	$\geq 40$ mm
<b>Colour</b>	RAL 7033
<b>Shock Resistance</b>	As per IEC 61373
<b>Vibration</b>	As per IEC 61373

**2. Standards**

Standard	Description
IEC61881-1	Rolling stock equipment – capacitors for power electronics
IEC61373	Shock and vibration test
EN50125-1	Environmental conditions
IEC61376	Creepage and clearance

**3. Functional requirements**

Description	Value	Unit
Operating hours	8640	hours/year
Typical load	continuous operation	
Surge current	1	times/year



A4 - 12

**PURCHASE SPECIFICATION FOR  
1085µF RESONANT CAPACITOR  
GROUP: TRACTION ENGINEERING**

P.S NO. : PS4452714

REV. NO: 00

PAGE 04 OF 07

**4. Ambient conditions / operating conditions**

Description	Value	Unit	Notes
Operating Temperature	-25..+85	°C	
Temperature distribution over the year	+75	°C	10 days/year
	+65	°C	20 days/year
	+55	°C	90 days/year
	+40	°C	100 days/year
	< +40	°C	130 days/year
Storage	-25..+70	°C	
Average year temperature	+ 40	°C	
Relative humidity	< 95	%	During app 3 - 4 months (rainy season) per year frequent condensation can occur
Altitude	<1200	m	
Pollution levels			
Operation in coastal areas			
Maximum PH	8.5		of water damp
Max. concentration of sulphate	7	mg/liter	of water damp
Max. concentration of chlorine	6	mg/liter	of water damp
Maximum conductivity	130	µS/cm	of water damp
Operation in desert terrain			
Dust content in air	1.6	mg/m3	

**5. Reliability, availability, maintainability and safety**

Description	Value	Unit	Notes
Design life	30	years	Expected lifetime: 30 x 8640 = 260000 hours
Failure rate	50	FIT	
Maintenance			To be defined by supplier
Safety			The risk of explosion due to over voltage, ageing, loss or other reasons should be minimized

COPYRIGHT AND CONFIDENTIAL  
The information on this document is the property of BHARAT HEAVY ELECTRICALS LIMITED.  
It must not be used directly or indirectly in anyway detrimental to the interest of the company.



**PURCHASE SPECIFICATION FOR  
1085 $\mu$ F RESONANT CAPACITOR  
GROUP: TRACTION ENGINEERING**

P.S NO. : PS4452714

REV. NO: 00

PAGE 05 OF 07

A4 - 12

**6. Dimensional details**

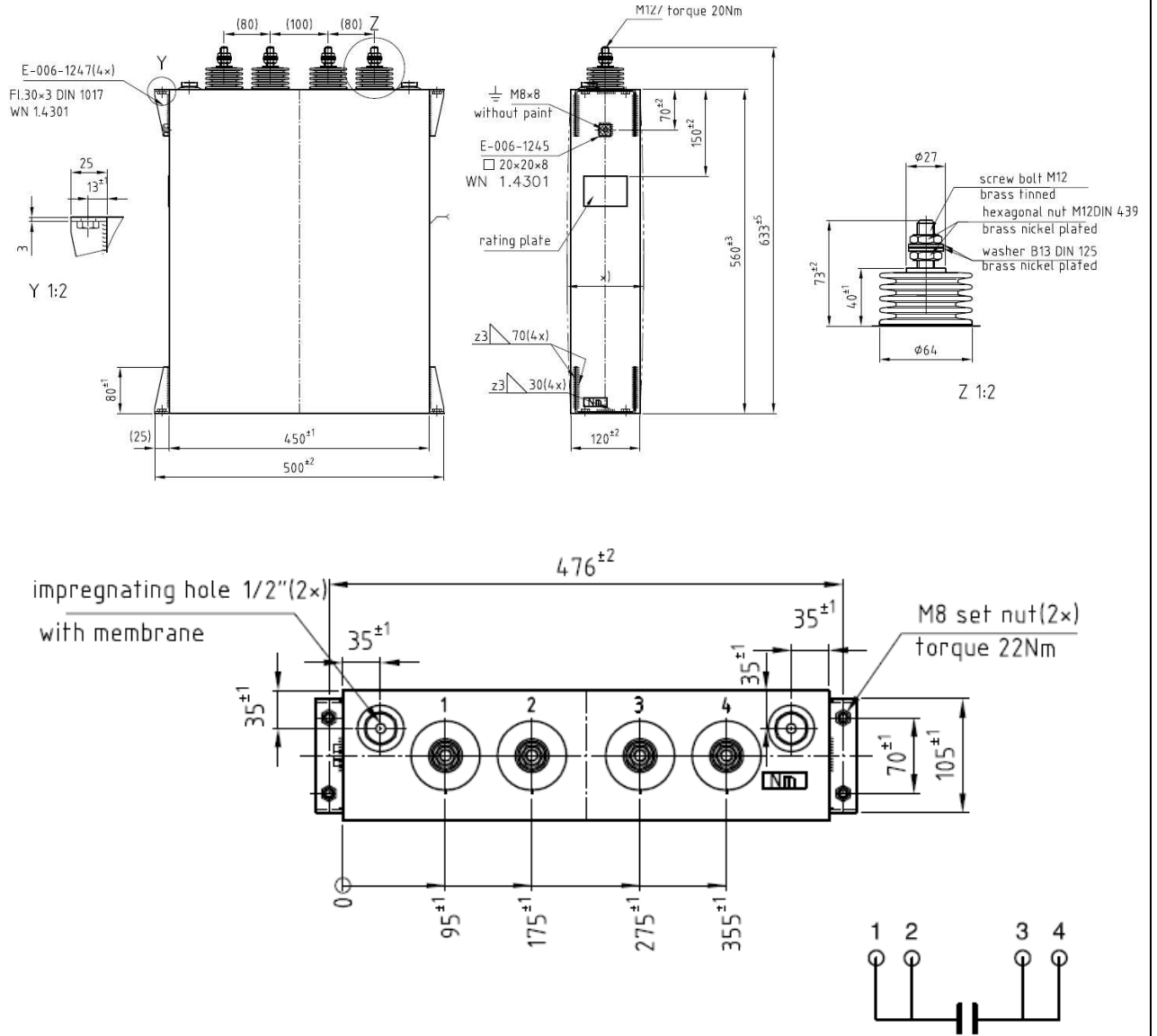

**Fig 2: Dimensional Drawing**

COPYRIGHT AND CONFIDENTIAL  
 The information on this document is the property of BHARAT HEAVY ELECTRICALS LIMITED.  
 It must not be used directly or indirectly in anyway detrimental to the interest of the company.



**PURCHASE SPECIFICATION FOR  
1085 $\mu$ F RESONANT CAPACITOR  
GROUP: TRACTION ENGINEERING**

P.S NO. : PS4452714

REV. NO: 00

PAGE 06 OF 07

**A4 - 12**

**7. Testing**

List of tests to be performed on prototype as per IEC 61881 are as follows

Sl No	Test	Acceptance criteria	Type/Routine Test
1	Capacitance and Tan $\delta$ measurement	Measurements should be within the tolerances specified by the manufacturer	Type/Routine
2	Dimensional check	Dimensions to comply with the Approved drawing	Type/Routine
3	Voltage test between terminals and case	During the test neither flashover nor puncture should occur.	Type/Routine
4	Voltage test between terminals	During the test neither flashover nor puncture should occur. Capacitance measured after the test should be within the range specified	Type/Routine
5	Surge discharge test	After conducting the test capacitance to be measured and the change should be < +/-1%	Type
6	Thermal stability test and loss angle tangent measurement test	No breakdown of the capacitor should occur during the test. The capacitor losses should be measured after the test and should be within the tolerances specified by the manufacturer	Type
7	Self-healing test	Change of capacitance after the test should be < +/- 0.5%	Type
8	Resonance frequency measurement	The self-inductance measured should be within the tolerances specified by the manufacturer	Type
9	Environmental Test 1. Damp heat test 2. Change of temperature	Change of capacitance after the test should be < +/-2%	Type
10	Mechanical tests Mechanical tests of terminals 1. External inspection 2. Vibration and shocks	No mechanical damage should occur after the test.	Type
11	Endurance test	Change of capacitance after the test should be < +/-3%	Type

COPYRIGHT AND CONFIDENTIAL  
The information on this document is the property of BHARAT HEAVY ELECTRICALS LIMITED.  
It must not be used directly or indirectly in anyway detrimental to the interest of the company.





A4 – 12

**PURCHASE SPECIFICATION FOR  
1085 $\mu$ F RESONANT CAPACITOR  
GROUP: TRACTION ENGINEERING**

P.S NO. : PS4452714

REV. NO: 00

PAGE 07 OF 07

## 8. Rating plate

The following information shall be given on the rating plate of each capacitor unit:

1. Manufacturer
2. Identification number and manufacturing date
3.  $C = \mu\text{F}$
4. Tol = %
5. UNDC or UN = V
6.  $\theta \text{ min} = ^\circ\text{C}$
7.  $\theta \text{ max} = ^\circ\text{C}$
8. Maximum tightening torque = Nm

## 9. Documentation

1. Datasheet
2. Dimensional Drawing
3. Type test Procedure, Type test Report
4. Routine test Procedure, Routine test Report

## 10. Acceptance

1. Routine test report to be submitted along with each delivery
2. Equipment shall be packed in a manner suitable for delivery and storage at the appointed delivery address. Transport packaging will provide adequate protection against accidental damage during normal handling. Terminals, leads, mounting brackets will be protected from mechanical damage

### Notes:

1. Mounting dimensions needs to be strictly adhered as per the approved drawing submitted by the vendor
2. Supplier should try to minimize the self-inductance and series resistance to a lower value as much as possible

COPYRIGHT AND CONFIDENTIAL  
The information on this document is the property of BHARAT HEAVY ELECTRICALS LIMITED.  
It must not be used directly or indirectly in anyway detrimental to the interest of the company.

COMMERCIAL BID				
Tender department: CE- MM, EDN, BHEL, BANGALORE			RFQ/NIT/Enquiry no.	AKSPROP003
			Bidder Name:	
<b>Item: CAPACITOR 1.085mF 2800Vdc 300A</b>				
Tender floated through NIC e-Procurement system Website - <a href="https://eprocurebhel.co.in/nicgep/app">https://eprocurebhel.co.in/nicgep/app</a> . Vendor to submit offer only through NIC e-Procurement system.				
Sr. No	DESCRIPTION	Details	Bidder's Acceptance / Response	Remarks if any
1	Price Basis	The quoted prices will be firm till supply completion of the tendered quantity.		
2	Terms of Delivery	<b>Indigenous vendors</b> -DDL, BHEL EDN, Bangalore (Free delivery to EDN/BHEL Bangalore including packing & forwarding charges) <b>Foreign Vendors</b> - FCA to International Airport(Airport Name to be indicated).		
3	Delivery Period	Total quantity requirement is for 1 year. Indicate the best possible delivery schedule from the date of issue of Purchase order with Best possible quantity per Month. BHEL will consider the production program and release order accordingly.		
4	Payment Term	<b>Indigenous vendors</b> - 100% within 45 days from the date of receipt of material at BHEL EDN Stores. <b>Foreign Vendors</b> - 100% against Sight draft with 45 days credit.( 45 days from the receipt of documents at our Bank will be considered)		
5	Evaluation of L1 vendor	Evaluation will be done on item wise, lowest bidder will be considered for ordering.		
6	Penalty for delay in delivery	Penalty of 0.5% per week at the basic price of the good for undelivered quantity of supply portion, subject to a maximum of 10%.If PSI is indicated in PO, then date of call letter with the test reports will be considered as the delivery date for penalty . If no PSI(Foreign vendors), then date will be as per NIT terms for supply of material.(i.e., Invoice date or date of intimation to freight forwarder which ever is earlier)		
7	Loading towards Penalty for delay in delivery	For any deviation in penalty term, the offer will be liable for loading as per Clause No. G, Point No.(b) of ITB.		
8	Pre shipment inspection	Not applicable. Test Certificate required as per Specification.		
9	Other terms & conditions	For detailed Terms and Conditions, kindly refer to the following:A: INSTRUCTIONS TO BIDDERS/SELLERS(Doc No :BHEL:EDN:ITB-SHOP) available at <a href="http://www.edn.bhel.com">www.edn.bhel.com</a> (RFQ-PO Terms & Conditions)B: GENERAL CONDITIONS OF CONTRACT FOR PURCHASE(Doc no :BHEL:EDN:GCC-SHOP)available at <a href="http://www.edn.bhel.com">www.edn.bhel.com</a> (RFQ-PO Terms & Conditions)		
10	Validity	Quotation should remain valid for a period of 90 days from the due date.		
11	Reverse Auction	Applicable.		
12	Declaration for GFR 2017 Rule 144(Xi)	Declaration to be uploaded (Format attached)		
13	Declaration for Make in India (MII)	Declaration to be uploaded (Format attached).		
14	Declaration	The bidder declares that they will not enter into any illegal or undisclosed agreement of understanding, whether formal or informal with other bidder(s). This applies in particular to prices, specifications, subsidiary contracts, submission or non-submission of bids or any other actions to restrict competitiveness or to introduce cartelization in the bidding process. In case, the Bidder is found having indulged in above activities, suitable action shall be taken by BHEL as per extent policies/guidelines.		
15	Warranty	12months from date of commissioning or 18 months from the date of supply whichever is earlier		
16	No Deviation	We hereby confirm that all the terms & conditions of tender are accepted without any deviation and any . Any additional commercial term or deviation in commercial term mentioned anywhere else shall be ignored and not be considered for evaluation		
17	Rate Contract	This RFQ is for entering into Rate contract (RC) with BHEL for the tendered item . Validity of the RC will be 1 year from the award of rate contract. Firm orders will be placed during the tenure of rate contract. Prices will remain firm till the validity of RC or till the completion of supplies against the purchase orders placed against this rate contract whichever later. Please note that these quantities are projections based on the current business scenario and expected orders from customers. In the eventuality of business not coming through, BHEL is not obligated to exhaust the ordering of RC quantities.		
18	Non acceptance of RC	Offer will be liable for commercial rejection for non acceptance of RC.		
19	Authorisation letter	Valid authorisation letter from OEM to be provided if dealer.		

Sr. No	DESCRIPTION	Details	Bidder's Acceptance / Response	Remarks if any
20	Documents for bill processing	<p>Complete set of despatch documents (original + 1 photocopy set) as per Purchase Order shall be submitted as below:</p> <p>1. For Indigenous vendors documents to be sent to the purchase Officer directly on below address for bill processing - Mr. Abhishek, Dy. MANAGER /CE-MM, NEB , 2ND FLOOR, BHEL-EDN, BANGALORE - 560026, KARNATAKA Telephone: 080-26998102</p> <p>If documents are Digitally Signed by Authorized Signatory, submission of Hard copy of document is not required. However digitally signed soft copy of complete set of documents to be sent to below email IDs, singh.abhishek@bhel.in</p> <p>Depending upon the PO, despatch documents may include one or more documents from the following:</p> <ol style="list-style-type: none"> <li>1. Invoice for payment (original)</li> <li>2. Invoice for payment (extra copy)</li> <li>3. Packing list</li> <li>4. LR Copy</li> <li>5. Warranty certificate</li> <li>6. PBG if applicable as per PO</li> <li>7. Copy of UDYAM certificate for considering MSE, if applicable.</li> <li>8. Copy of First Inspection call letter along with TC if applicable.</li> </ol>		
21	Note -			
	<p>(1) Any tender condition does not prohibit any bidder to submit their offer along with clause wise deviation from the specification/commercial terms of tender. Changes, if any, in technical specification / Scope etc shall be informed to participating bidders only.</p> <p>(2) Any additional commercial term or deviation in commercial term, if sought by vendor, should be clearly brought out in this commercial bid document. Any additional commercial term or deviation in commercial term mentioned anywhere else shall be ignored and not be considered for evaluation</p> <p>(3) Any technical or commercial clarification for this tender can be raised within <b>one week</b> of floating tender. No clarification will be entertained by BHEL after given cutoff date. Clarifications with regard to the tender shall be addressed to purchase officers whose e-mail IDs are given below: singh.abhishek@bhel.in</p> <p>(4) The evaluation currency for this tender shall be INR.</p> <p>(5) Only Class-I and Class-II Local suppliers as per MII order dated 04.06.2020 are eligible to bid in this tender. Minimum 50% Local content required for qualifying as Class I Local Supplier and Minimum 20% Local content required for qualifying as Class II Local Supplier.</p>			

# Special Conditions of Contract

## Clause on IP in the tender

### “Integrity Pact (IP)”

**RFQ No: AKSPROP003**

(a) IP is a tool to ensure that activities and transactions between the Company and its Bidders/ Contractors are handled in a fair, transparent and corruption free manner. Following Independent External Monitors (IEMs) on the present panel have been appointed by BHEL with the approval of CVC to oversee implementation of IP in BHEL.

SI No.	IEM	Email
1.	Shri Arun Chandra Verma, IPS (Retd.)	<a href="mailto:acverma1@gmail.com">acverma1@gmail.com</a>
2.	Shri Virendra Bahadur Singh, IPS (Retd.)	<a href="mailto:vbsinghips@gmail.com">vbsinghips@gmail.com</a>

(b) The IP as enclosed with the tender is to be submitted (duly signed by authorized signatory) along with techno-commercial bid (Part-I, in care of two/three part bid). Only those bidders who have entered into such an IP with BHEL would be competent to participate in the bidding. In other words, entering into this Pact would be a preliminary qualification.

(c) Please refer Section-8 of IP for Role and Responsibilities of IEMs. In case of any complaint arising out of the tendering process, the matter may be referred to the above IEM. All correspondence with the IEMs shall be done through email only.

**Note:**

No routine correspondence shall be addressed to the IEM (phone/ post/ email) regarding the clarifications, time extensions or any other administrative queries, etc on the tender issued. All such clarification/ issues shall be addressed directly to the tender issuing (procurement) department's officials whose contact details are provided below:

Name : Mr Abhishek,	Name : Mr MASAND J P,
Department : CE-MM	Department : CE-MM
Address : BHEL EDN, NEB 2 <sup>nd</sup> Floor, Mysore Road, P B No. 2606, Bangalore - 560026.	Address : BHEL EDN, NEB 2 <sup>nd</sup> Floor, Mysore Road, P B No. 2606, Bangalore - 560026.
Phone : +91 80 2699 8102 / 9008891680	Phone : +91 26998391/ 9425604767
Email : <a href="mailto:singh.abhishek@bhel.in">singh.abhishek@bhel.in</a>	Email : <a href="mailto:jpmasand@bhel.in">jpmasand@bhel.in</a>
Fax : +91 80 26989215	Fax : +91 80 26989228

**INTEGRITY PACT****Between**

Bharat Heavy Electricals Ltd. (BHEL), a company registered under the Companies Act 1956 and having its registered office at "BHEL House", Siri Fort, New Delhi - 110049 (India) hereinafter referred to as "The Principal", which expression unless repugnant to the context or meaning hereof shall include its successors or assigns of the ONE PART

**and**

\_\_\_\_\_, (description of the party along with address), hereinafter referred to as "The Bidder/ Contractor" which expression unless repugnant to the context or meaning hereof shall include its successors or assigns of the OTHER PART

**Preamble**

The Principal intends to award, under laid-down organizational procedures, contract/s for \_\_\_\_\_

\_\_\_\_\_ (hereinafter referred to as "Contract"). The Principal values full compliance with all relevant laws of the land, rules and regulations, and the principles of economic use of resources, and of fairness and transparency in its relations with its Bidder(s)/ Contractor(s).

In order to achieve these goals, the Principal will appoint panel of Independent External Monitor(s) (IEMs), who will monitor the tender process and the execution of the contract for compliance with the principles mentioned above.

**Section 1- Commitments of the Principal**

- 1.1 The Principal commits itself to take all measures necessary to prevent corruption and to observe the following principles: -
  - 1.1.1 No employee of the Principal, personally or through family members, will in connection with the tender for, or the execution of a contract, demand, take a promise for or accept, for self or third person, any material or immaterial benefit which the person is not legally entitled to.
  - 1.1.2 The Principal will, during the tender process treat all Bidder(s) with equity and reason. The Principal will in particular, before and during the tender process, provide to all Bidder(s) the same information and will not provide to any Bidder(s) confidential/ additional information through which the Bidder(s) could obtain an advantage in relation to the tender process or the contract execution.
  - 1.1.3 The Principal will exclude from the process all known prejudiced persons.
- 1.2 If the Principal obtains information on the conduct of any of its employees which is a penal offence under the Indian Penal Code 1860 and Prevention of Corruption Act 1988 or any other statutory penal enactment, or if there be a substantive suspicion in this regard, the Principal will inform its Vigilance Office and in addition can initiate disciplinary actions:

**Section 2 - Commitments of the Bidder(s)/ Contractor(s)**

- 2.1 The Bidder(s)/ Contractor(s) commit himself to take all measures necessary to prevent corruption. The Bidder(s)/ Contractor(s) commits himself to observe the following principles during participation in the tender process and during the contract execution.

*Handwritten signature/initials in blue ink.*

- 2.1.1 The Bidder(s)/ Contractor(s) will not, directly or through any other person or firm, offer, promise or give to the Principal or to any of the Principal's employees involved in the tender process or the execution of the contract or to any third person any material, immaterial or any other benefit which he/ she is not legally entitled to, in order to obtain in exchange any advantage of any kind whatsoever during the tender process or during the execution of the contract.
- 2.1.2 The Bidder(s)/ Contractor(s) will not enter with other Bidder(s) into any illegal or undisclosed agreement or understanding, whether formal or informal. This applies in particular to prices, specifications, certifications, subsidiary contracts, submission or non-submission of bids or any other actions to restrict competitiveness or to introduce cartelization in the bidding process.
- 2.1.3 The Bidder(s)/ Contractor(s) will not commit any penal offence under the relevant Indian Penal Code (IPC) and Prevention of Corruption Act; further the Bidder(s)/ Contractor(s) will not use improperly, for purposes of competition or personal gain, or pass on to others, any information or document provided by the Principal as part of the business relationship, regarding plans, technical proposals and business details, including information contained or transmitted electronically.
- 2.1.4 Foreign Bidder(s)/ Contractor(s) shall disclose the name and address of agents and representatives in India and Indian Bidder(s)/ Contractor(s) to disclose their foreign principals or associates. The Bidder(s)/ Contractor(s) will, when presenting his bid, disclose any and all payments he has made, and is committed to or intends to make to agents, brokers or any other intermediaries in connection with the award of the contract.
- 2.2 The Bidder(s)/ Contractor(s) will not instigate third persons to commit offences outlined above or be an accessory to such offences.
- 2.3 The Bidder(s)/ Contractor(s) shall not approach the Courts while representing the matters to IEMs and shall await their decision in the matter.

### Section 3 - Disqualification from tender process and exclusion from future contracts

If the Bidder(s)/ Contractor(s), before award or during execution has committed a transgression through a violation of Section 2 above, or acts in any other manner such as to put his reliability or credibility in question, the Principal is entitled to disqualify the Bidder(s)/ Contractor(s) from the tender process, terminate the contract, if already awarded, exclude from future business dealings and/ or take action as per the separate "Guidelines on Banning of Business dealings with Suppliers/ Contractors", framed by the Principal.

### Section 4 - Compensation for Damages

- 4.1 If the Principal has disqualified the Bidder (s) from the tender process before award / order acceptance according to Section 3, the Principal is entitled to demand and recover the damages equivalent to Earnest Money Deposit/ Bid Security.
- 4.2 If the Principal is entitled to terminate the Contract according to Section 3, or terminates the Contract in application of Section 3 above, the Bidder(s)/ Contractor (s) transgression through a violation of Section 2 above shall be construed breach of contract and the Principal shall be entitled to demand and recover from the Contractor an amount equal to 5% of the contract value or the amount equivalent to Security Deposit/ Performance Bank Guarantee, whichever is higher, as damages, in addition to and without prejudice to its right to demand and recover compensation for any other loss or damages specified elsewhere in the contract.

**Section 5 - Previous Transgression**

- 5.1 The Bidder declares that no previous transgressions occurred in the last 3 (three) years with any other company in any country conforming to the anti-corruption approach or with any other Public Sector Enterprise in India that could justify his exclusion from the tender process.
- 5.2 If the Bidder makes incorrect statement on this subject, he can be disqualified from the tender process or the contract, if already awarded, can be terminated for such reason or action can be taken as per the separate "Guidelines on Banning of Business dealings with Suppliers/ Contractors", framed by the Principal.

**Section 6 - Equal treatment of all Bidder (s)/ Contractor (s) / Sub-contractor (s)**

- 6.1 The Principal will enter into Integrity Pacts with identical conditions as this Integrity Pact with all Bidders and Contractors.
- 6.2 In case of Sub-contracting, the Principal Contractor shall take the responsibility of the adoption of Integrity Pact by the Sub-contractor(s) and ensure that all Sub-contractors also sign the Integrity Pact.
- 6.3 The Principal will disqualify from the tender process all Bidders who do not sign this Integrity Pact or violate its provisions.

**Section 7 - Criminal Charges against violating Bidders/ Contractors /Subcontractors**

If the Principal obtains knowledge of conduct of a Bidder, Contractor or Subcontractor, or of an employee or a representative or an associate of a Bidder, Contractor or Subcontractor which constitutes corruption, or if the Principal has substantive suspicion in this regard, the Principal will inform the Vigilance Office.

**Section 8 -Independent External Monitor(s)**

- 8.1 The Principal appoints competent and credible panel of Independent External Monitor (s) (IEMs) for this Integrity Pact. The task of the IEMs is to review independently and objectively, whether and to what extent the parties comply with the obligations under this Integrity Pact.
- 8.2 The IEMs are not subject to instructions by the representatives of the parties and performs his functions neutrally and independently. He reports to the CMD, BHEL.
- 8.3 The IEMs shall be provided access to all documents/ records pertaining to the Contract, for which a complaint or issue is raised before them as and when warranted. However, the documents/records/information having National Security implications and those documents which have been classified as Secret/Top Secret are not to be disclosed.
- 8.4 The Principal will provide to the IEMs sufficient information about all meetings among the parties related to the Contract provided such meetings could have an impact on the contractual relations between the Principal and the Contractor. The parties offer to the IEMs the option to participate in such meetings.

- 8.5 The advisory role of IEMs is envisaged as that of a friend, philosopher and guide. The advice of IEMs would not be legally binding and it is restricted to resolving issues raised by a Bidder regarding any aspect of the tender which allegedly restricts competition or bias towards some Bidders. At the same time, it must be understood that IEMs are not consultants to the Management. Their role is independent in nature and the advice once tendered would not be subject to review at the request of the organization.
- 8.6 For ensuring the desired transparency and objectivity in dealing with the complaints arising out of any tendering process or during execution of Contract, the matter should be examined by the full panel of IEMs jointly, who would look into the records, conduct an investigation, and submit their joint recommendations to the Management.
- 8.7 The IEMs would examine all complaints received by them and give their recommendations/ views to the CMD, BHEL at the earliest. They may also send their report directly to the CVO, in case of suspicion of serious irregularities requiring legal/ administrative action. Only in case of very serious issue having a specific, verifiable Vigilance angle, the matter should be reported directly to the Commission. IEMs will tender their advice on the complaints within 30 days.
- 8.8 The CMD, BHEL shall decide the compensation to be paid to the IEMs and its terms and conditions.
- 8.9 IEMs should examine the process integrity, they are not expected to concern themselves with fixing of responsibility of officers. Complaints alleging mala fide on the part of any officer of the Principal should be looked into by the CVO of the Principal.
- 8.10 If the IEMs have reported to the CMD, BHEL, a substantiated suspicion of an offence under relevant Indian Penal Code / Prevention of Corruption Act, and the CMD, BHEL has not, within reasonable time, taken visible action to proceed against such offence or reported it to the Vigilance Office, the IEMs may also transmit this information directly to the Central Vigilance Commissioner, Government of India.
- 8.11 After award of work, the IEMs shall look into any issue relating to execution of Contract, if specifically raised before them. As an illustrative example, if a Contractor who has been awarded the Contract, during the execution of Contract, raises issue of delayed payment etc. before the IEMs, the same shall be examined by the panel of IEMs. Issues like warranty/ guarantee etc. shall be outside the purview of IEMs.
- 8.12 However, the IEMs may suggest systemic improvements to the management of the Principal, if considered necessary, to bring about transparency, equity and fairness in the system of procurement.
- 8.13 The word 'Monitor' would include both singular and plural.

#### Section 9 - Pact Duration

- 9.1 This Integrity Pact shall be operative from the date this Integrity Pact is signed by both the parties till the final completion of contract for successful Bidder, and for all other Bidders 6 months after the Contract has been awarded. Any violation of the same would entail disqualification of the bidders and exclusion from future business dealings.
- 9.2 If any claim is made/ lodged during currency of this Integrity Pact, the same shall be binding and continue to be valid despite the lapse of this Pact as specified above, unless it is discharged/ determined by the CMD, BHEL.

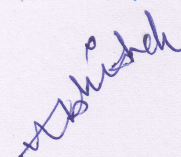



**Section 10 - Other Provisions**

- 10.1 This Integrity Pact is subject to Indian Laws and exclusive jurisdiction shall be of the competent Courts as indicated in the Tender or Contract, as the case may be.
- 10.2 Changes and supplements as well as termination notices need to be made in writing.
- 10.3 If the Bidder(s)/ Contractor(s) is a partnership or a consortium or a joint venture, this Integrity Pact shall be signed by all partners of the partnership or joint venture or all consortium members.
- 10.4 Should one or several provisions of this Integrity Pact turn out to be invalid, the remainder of this Integrity Pact remains valid. In this case, the parties will strive to come to an agreement to their original intentions.
- 10.5 Only those bidders / contractors who have entered into this Integrity Pact with the Principal would be competent to participate in the bidding. In other words, entering into this Integrity Pact would be a preliminary qualification.
- 10.6 In the event of any dispute between the Principal and Bidder(s)/ Contractor(s) relating to the Contract, in case, both the parties are agreeable, they may try to settle dispute through Mediation before the panel of IEMs in a time bound manner. In case, the dispute remains unresolved even after mediation by the panel of IEMs, either party may take further action as the terms & conditions of the Contract. The fees/expenses on dispute resolution through mediation shall be shared by both the parties. Further, the mediation proceedings shall be confidential in nature and the parties shall keep confidential all matters relating to the mediation proceedings including any settlement agreement arrived at between the parties as outcome of mediation. Any views expressed, suggestions, admissions or proposals etc. made by either party in the course of mediation shall not be relied upon or introduced as evidence in any further arbitral or judicial proceedings, whether or not such proceedings relate to the dispute that is the subject of mediation proceedings. Neither of the parties shall present IEMs as witness in any Alternative Dispute Resolution or judicial proceedings in respect of the dispute that was subject of mediation.

ಅಭಿಷೇಕ, ಉಪ ವ್ಯವಸ್ಥಾಪಕರು/ನಿ.ಉ.-ಎಂ.ಎಂ.-ಎಂ.ಪಿ.ಸಿ.  
 ಅಭಿಷೇಕ, ಉಪ-ಪ್ರबंधक/सी.ई.-एम.एम.-एम.पी.सी.  
 For & On Behalf of the Principal-EM-MPC  
 BHEL-EDN, (Office Seal), MYSURU ROAD, BENGALURU-560026

Place Bangalore  
 Date 22/04/2022

Witness: [Signature]  
 (Name & Address) \_\_\_\_\_

ರೆಡ್ಡೆಪ್ಪ ಅಂಗಜಾಲ, ಹಿರಿಯ ವ್ಯವಸ್ಥಾಪಕರು/ನಿ.ಉ.-ಎಂ.ಎಂ.  
 रेड्डेप्पा अंगजाल, वरिष्ठ प्रबंधक/सी.ई.-एम.एम.  
 REDDEPPA ANGAJALA, SR. MANAGER/CE-MM  
 BHEL-EDN, MYSURU ROAD, BENGALURU-560026

For & On behalf of the Bidder/ Contractor  
 (Office Seal)

Witness: \_\_\_\_\_  
 (Name & Address) \_\_\_\_\_