

Annexure For Techno Commercial Bid

Check List - to be filled and submitted along with Technical Bid

BHEL Commercial Terms and Conditions for Indigenous Supplies	Vendor's Confirmation / Comments
Technical confirmation to BHEL's Specification as called for in BHEL Format shall be furnished. If needed additional sheets shall be used.	
Prices shall be quoted item wise only as per the model format enclosed	
Prices shall be quoted on " FIRM PRICE " basis only The prices should be only on F.O.R / Despatching station basis with Packing & Forwarding charges if any. Applicable % of GST & Freight & Insurance, Installation & Commissioning Charges should be clearly Indicated	
Validity of offer shall be for a minimum period of 120 days from the date of Tender opening	
Delivery period from the date of Letter of Intent / Purchase order shall be clearly mentioned in the offer	
Liquidated damages @ '0.5% per week subject to a maximum of 10% of the order value shall be applicable for delay in deliveries For Details Refer Annexure- v	
Following Risk Purchase clause shall be applicable The purchaser at his option will be entitled to terminate the contract and to purchase elsewhere at the risk and cost of the seller either the whole of the goods or any part which the supplier has failed to deliver or dispatch within the time stipulated or if the same were not available, the best and the nearest available substitute therefore The supplier shall be liable for any loss which the Purchaser may sustain by reason of such risk purchases	
Payment term for supply portion: Payment term is 100% direct payment after 45 days from the date of receipt and acceptance of materials For details Refer Annexure- v	
Erection / commissioning: (if applicable only) Erection / commissioning charges if any has been mentioned in the offer or else confirmation that Erection /commissioning shall be done at free of cost is available in the offer,	
The equipment shall be guaranteed for a period of 12 months from the date of commissioning	
Final inspection and acceptance of equipment will be after installation at BHEL, Trichy	
The vendor shall provide necessary drawings, Test Certificates and Operating Maintenance Manuals etc., as called for in the Technical Specification, in the required number of copies at no extra cost	
Any warranty replacement during warranty period shall be supplied free of charge on FOR BHEL, Trichy basis.	
Confirm MSE vendor or not (Incase of MSE vendor necessary documentary proof shall be furnished as per Annexure VI)	
% of applicable GST	
Packing & Forwarding Charges (if any in % only)	
Percentage of Freight& transit insurance charges, if any Freight charges from Dispatching station to BHEL, Tiruchirappalli • Supplier should quote for F.O.R-BHEL Trichy Stores.	
As per Commercial terms and conditions, acceptance for participation in Reverse auction (RA).Yes/No to be indicated	
Name of the person for participating reverse auction	
Land Line Number	
Fax Number	
Mobile Number	
E-mail ID	

NOTE:-

- It is confirmed that all the terms and conditions stipulated in the Enquiry have been fully understood by us and all clarifications & details have been obtained.
- Your offer should be indicating applicable if any P&F Charges, % of GST, Freight, Insurance and Installation and Commissioning Charges etc., as per our Price Format
- Your specific acceptance to our Payment terms, LD & Risk Purchase Clause are essential for consideration of your offer. Other wise your offer is liable for rejection.
- No row shall be left blank. Please indicate NA, in case the item is "not applicable"

Offers of indigenous Suppliers with any other Payment terms will be rejected.	
Payment Term (Indigenous)	
If offer is received from both OEM/Manufacturer and authorized dealers or agent, then OEM/Manufacturer offer will only be considered and dealers or agent offer will be ignored.	
If materials are receivable at Stores/Trichy without PBG	Payment term is 100% direct payment after 45 days from the date of receipt and acceptance of materials.
If materials are receivable at Stores/Trichy with PBG	Payment term is 100% direct payment after 45 days from the date of receipt and acceptance of materials and against 10% PBG valid for the warranty period.
Any deviation in the above payment term will attract loading as mentioned below. “Base rate of SBI (as applicable on the date of bid opening. Techno-commercial bid opening in case of two part bids) + 6% shall be considered for loading for the period of relaxation sought by bidders.	

Liquidated Damages / Penalty -
The delivery of the goods specified in the purchase order should be made within the time prescribed. LD for delay in 'Supply' and/or 'E&C' will be applicable to the delays attributed to vendor. LD will be considered separately for 'Delivery' and 'E&C'. Where the seller supplies or dispatches the goods, beyond the delivery period Liquidated damages shall be applicable 0.5% of the total order value per week or part thereof subject to a maximum of 10% of the total order value. Material Despatched after Due date: Once the delivery due date is crossed, bills have to be clubbed till final despatch and forwarded for processing of payment as a single bunch. LD percentage will be calculated from Delivery due date to final despatch date. The rate of LD for delayed E&C shall be @ 0.5% per week of delay of total PO value (Supply + E&C) in E&C subject to a maximum of 10% of total PO value (Supply + E&C). For staggered delivery schedule, LD shall be 0.5% of the undelivered portion per week of the delay or part thereof subject to a maximum of 10% of the total order value. Any deviation from the above LD clause, loading will be applied to the extent to which it is not agreed by the bidder (at offered value). For the purpose of Imposing LD, the FOB delivery (B/L date) shall be considered.

Guarantee / Warranty Period – (if applicable)
Normally No deviation permitted and the deviated offers are liable for rejection.

Ranking-
BHEL will consider the ranking after the loading is applied as referred above wherever deviations are observed.

Performance Bank Guarantee – (if applicable)
Normally No deviation permitted and the deviated offers are liable for rejection.

Fraud prevention clause: The bidder along with its associate/collaborator/sub-contractor/sub-vendor/consultants/service providers shall strictly adhere to BHEL fraud prevention policy displayed on BHEL website <http://www.bhel.com> and shall immediately bring to the notice of BHEL management about any fraud or suspected fraud as soon as it comes to their notice.

- NOTE:-**
1. If the due date of tender opening happens to be a holiday, the tenders will be opened on the next working day.
 2. BHEL reserves the right to go for a reverse auction (RA) instead of opening the submitted bid which will be decided after technical evaluation. Information and general terms and conditions covering RA are given in commercial terms and conditions.
 3. Corrigendum if any, with respect to this tender will be hosted only in the website <http://www.bhel.com> or <http://tenders.gov.in>. You are requested to visit the website regularly for updates.

Special Provisions for Micro and Small Enterprises (MSE)

1. 20% of the tendered quantity is earmarked for MSE suppliers in this tender.

2. Out of the 20% tendered quantity reserved for MSE suppliers, 4% shall be earmarked for procurement from MSE owned by SC/ST entrepreneurs.
Such Micro/Small Enterprises registered vendors must state the sub-category to which they belong and submit documentary proof for the same. The sub-categories are:
 - (a) Enterprises owned by Scheduled Castes.
 - (b) Enterprises owned by Scheduled Tribes.
 - (c) Enterprises owned by other than above two categories

The enterprises under (a) & (b) means the proprietor in case of single owned firm and all partners in case of partnership firm and all directors in case of private/public limited must belong to SC/ST category.

3. In case MSE vendor participating in the tender quotes within the price band of L1+15%, they will be allowed to supply the portion of the requirement subject to acceptance of L1 price by MSE vendor. In case of more than one such MSE, the supply shall be shared proportionately.

4. "MSE suppliers can avail the intended benefits only if they submit along with the offer, attested copies of either EM II certificate having deemed validity (five years from the date of issue of acknowledgement in EM-II) or valid NSIC certificate or EM II certificate along with attested copy of a CA certificate (Format enclosed at Annexure -VII where deemed validity of EM II certificate of five Years has expired) applicable for the relevant financial year (latest audited). Date to be reckoned for determining the deemed validity will be the date of bid opening (Part 1 in case of two part bid). Non submission of such documents will lead to consideration of their bid at par with other bidders. No benefit shall be applicable for this enquiry if any deficiency in the above required documents are not submitted before price bid opening. If the tender is to be submitted through e-procurement portal, then the above required documents are to be uploaded on the portal. Documents should be notarized or attested by a Gazetted officer."

Certificate by Chartered Accountant

This is to certify that M/s., hereinafter referred to as 'company') having its registered office at is registered under MSMED Act 2006, Entrepreneur Memorandum No (Part - II) dtd:....., Category :.....(Micro / Small)). (Copy enclosed).

Further verified from the Books of Accounts that the investment of the company as on date as per MSMED Act 2006 is as follows:

1. For Manufacturing Enterprises: Investment in plant and machinery (i.e. original cost excluding land and building and the items specified by the Ministry of Small Scale Industries vide its notification No.5.0.1722(E) dated October 5, 2006:

Rs.....Lacs

2. For Service Enterprises: Investment in equipment (original cost excluding land and building and furniture, fittings and other items not directly related to the service rendered or as may be notified under the MSMED Act, 2006:

Rs.....Lacs

The above investment of Rs..... Lacs is within permissible limit of Rs.....Lacs for Micro / Small (Strike off which is not applicable) Category under MSMED Act 2006.

Date:

(Signature)

Name -

Membership Number -

Seal of Chartered Accountant

Terms for GST:

For supplies after implementation of GST i.e. after 30.06.2017, the following conditions will

apply and supplier shall fully comply to the below points.

Indigenous suppliers:

1. Response to Tenders for Indigenous supplier will be entertained only if the vendor has a valid GST registration no which should clearly mentioned in the offer. If any specific exemption is available, a declaration with due supporting documents need to be furnished for considering the offer..
2. Supplier shall mention their GSTN registration number in all their invoices and invoices shall be in the format as specified/prescribed under GST laws. Invoices shall necessarily contain Invoice number (in case of multiple numbering system is being followed for billing like SAP invoice no, commercial invoice no etc., then the Invoice No which is linked/uploaded in GSTN network shall be clearly indicated), item description as per PO, Quantity, Rate, Value, applicable taxes with nomenclature (like IGST, SGST, CGST & UTGST) separately, HSN/ SAC Code, etc.
3. All invoices shall bear the HSN Code for each item separately (Harmonized System of Nomenclature)/ SAC code (Services Accounting Code).
4. A declaration to the effect that all invoice particulars are/were uploaded in the GSTN network/ portal & all tax liability as per GST rules and regulations have been and will be discharged, shall be mentioned in the invoice. If not mentioned in the invoice, a separate declaration shall be submitted as per the requirement of BHEL.
5. All documents like Mill Test Certificate, LR copy, Guarantee/Warranty certificate, work completion certificate, any other document mentioned in PO, shall be sent along with the vehicle/consignment. For all consignments received within the calendar month, input credit will be availed within that month in line with monthly returns filing cycle. In case of any discrepancy in the document or non-submission of documents mentioned in the PO, then BHEL will not be able to accept or account the material, in such case availing of tax credit will be deferred to next month or so.
6. In case of discrepancy in the data uploaded by supplier in the GSTN portal or in case of any shortages or rejection in the supply, then BHEL will not be able to avail the tax credit and will notify the supplier of the same. Supplier has to rectify the data discrepancy in the GSTN portal or issue credit note (details to be uploaded in GSTN portal) for the shortages or rejections in the suppliers, within the calendar month notified by BHEL.
7. For any such delay in availing of tax credit for reasons attributable to supplier (as mentioned above), interest (calculated @ SBI Base Rate + 6%) alongwith penalty if any will be deducted for the delayed period i.e. from the month of receipt till the month tax credit is availed, from the running bills.
8. Under GST regime, BHEL has to discharge GST liability on LD recovered from suppliers/contractors. Hence applicable GST shall also be recoverable from suppliers/contractors on LD amount. For this Debit note will be issued by BHEL indicating the respective supply invoice number.

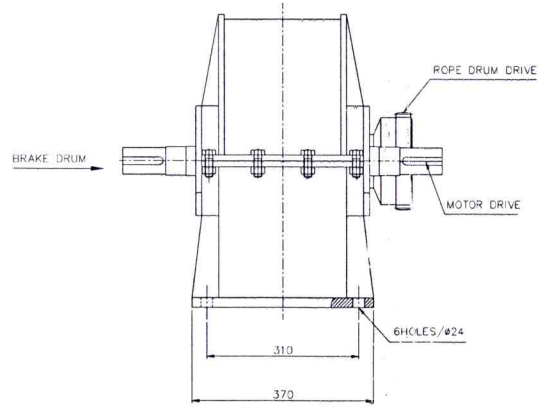
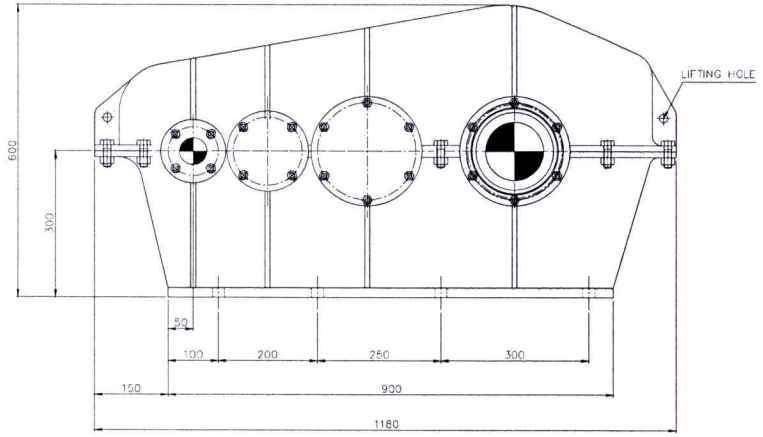

TECHNICAL DETAILS	
APPLICATION	CRANE DUTY - MAIN HOIST (10 TON)
SIZE / TYPE	650 HR HORIZONTAL SPLIT CASE 3 STAGE HELICAL GEARING
HANDING/ROTATION	AS SHOWN IN DRG/ BI-DIRECTIONAL
INPUT POWER OF MOTOR	18 KW
INPUT SPEED	960 RPM
OUTPUT SPEED	SUPPLIER TO FURNISH
RATIO	NOMINAL: 62:1
	ACTUAL: SUPPLIER TO FURNISH
SERVICE FACTOR	2
GEAR BOX RATED CAPACITY (CLASS-3, IS 4137)	36 KW
CASING MATERIAL	Fe410WR : IS, 20R2 (STRESS RELIEVED)
GEARS AND PINION SHAFT MATERIAL	20MnCr5 CASE HARDENED TO 58+3 HRC AND PROFILE GROUND EN 100B4
OUTPUT SHAFT MATERIAL	C60E, EN 100B3-2

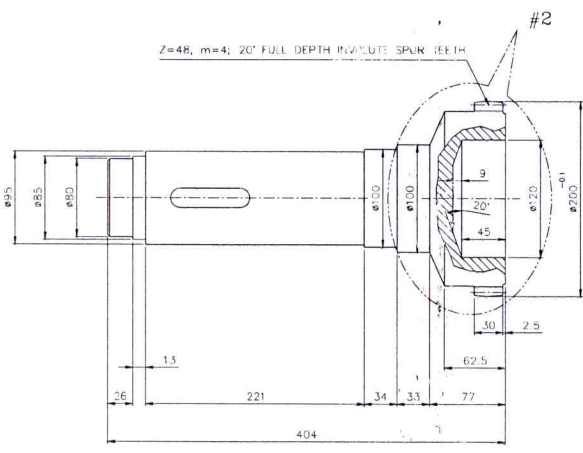
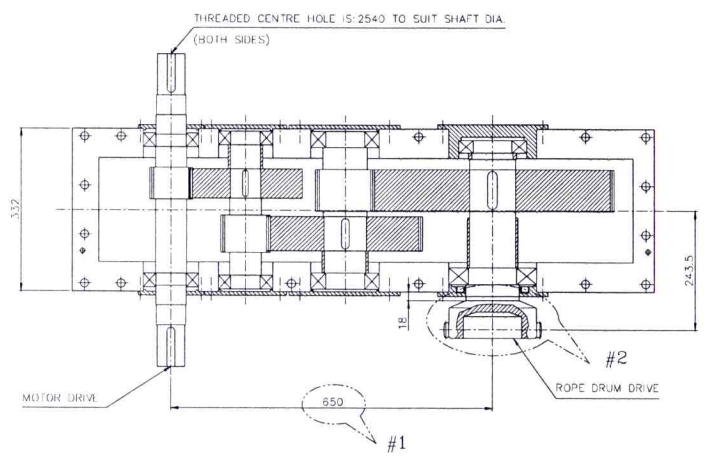

OUTPUT SHAFT
SCALE - 1:2.5

FOR TENDERING PURPOSE ONLY

NOTE:-
#1 AND #2 DIMENSIONS/FEATURES ARE MANDATORY.
OTHER DIMENSIONS ARE ONLY INDICATIVE.

ITEM NO	DESCRIPTION	DRAWING NO	MATL CODE	UNIT WT
EQUIP: 650 HR, HORIZONTAL SPLIT CASE, 3 STAGE HELICAL GEARING				
Shrihar Heavy Electricals Ltd HIGH PRESSURE BOILER PLANT TIRUCHIRAPPALLI - 620014			NAME: N. MAHADEVAIAH DES: G. GOVINDARAJU APPL: P. RAYAKRISHNAN	SIGNATURE: P. RAYAKRISHNAN DATE: 11.09.17
REV	DATE	ALTERED BY/REVISION	SCALE	WEIGHT (KG)
001		M&S	1:5	11.09.17
002		2587	1:2.5	
TITLE: HOIST GEAR BOX 650HR (PRINCIPAL DIMENSIONS FOR 10T MH)			DRAWING NO: M&S-PD-17-007	REV: 00