

CUSTOMER: UPRVUNL

**PROJECT: 1X660 MW PANKI THERMAL POWER
EXTENSION PROJECT**

TECHNICAL SPECIFICATION
FOR
**AUXILIARY STEAM PRESSURE REDUCING
AND DESUPERHEATING STATION
ALONGWITH ACCESSORIES**

SPECIFICATION No: PE-TS -426-142-N101



BHARAT HEAVY ELECTRICALS LIMITED
POWER SECTOR
PROJECT ENGINEERING MANAGEMENT
PPEI, NOIDA, INDIA

	TECHNICAL SPECIFICATION FOR AUXILIARY STEAM PRESSURE REDUCING & DESUPERHEATING STATION	SPEC. NO.: PE-TS-426-142-N101			
		SECTION	CONTENTS (I & II)		
		REV. NO.	00	DATE	03.01.20

CONTENTS

	<u>TITLE</u>	<u>PAGE NO.</u>
	<u>SECTION-I</u>	2-40
A	Scope of enquiry	
B	Project Information	
C	Specific Technical Requirements	
1.0	Brief System Description	
2.0	Sizing Data sheets (A-1)	
3.0	Data Sheets (A) for APRDS	
4.0	Tender Drawing	
5.0	Customer Specification	
	<u>SECTION-II</u>	41-72
	Specification for APRDS (Control Valve)	
1.0	Scope	
2.0	Codes And Standards	
3.0	Technical requirements	
4.0	Testing And Inspection	
5.0	Spares And Consumables	
6.0	Drawings And Documents	
7.0	Marking And Packing	
8.0	Hook-up Diagrams	
	Quality Plan for Control Valve	
	Compliance Certificate	
	Data Sheet-C for Control Valves	
	Schedule of Technical Deviation/ Clarification	



**TECHNICAL SPECIFICATION FOR
AUXILIARY STEAM PRESSURE REDUCING &
DESUPERHEATING STATION**

SPEC. NO.: PE-TS-426-142-N101

SECTION I

REV. NO. 00

DATE 13.01.20

SCOPE OF ENQUIRY



**TECHNICAL SPECIFICATION FOR
AUXILIARY STEAM PRESSURE REDUCING &
DESUPERHEATING STATION**

SPEC. NO.: PE-TS-426-142-N101

SECTION I

REV. NO. 00

DATE 13.01.20

- 1.1 This enquiry covers the Design, Manufacture, Assembly, Inspection and Testing at Vendor's and/or his sub-vendors works, painting and delivery to site of Auxiliary Steam Pressure Reducing & Desuperheating Stations, as mentioned in different sections of this specification.
- 1.2 It is not the intent to specify herein all the details of design and manufacture. However, the equipment shall conform in all respects to high standards of design, engineering and workmanship and shall be capable of performing the required duties in a manner acceptable to the Engineer/Owner who will interpret the meaning of drawings and specifications and shall be entitled to reject any work or material, which in his judgment is not in full accordance herewith.
- 1.3 The bidder may quote for his standard, proven design of equipment and shall submit stamped compliance certificate (enclosed in Section II) conforming all the specification requirements.
- 1.4 The bids shall be in English language and MKS Units.
- 1.5 Filled up quality plan as minimum technical requirements, is included in this specification in Sec-II. Bidder is required to submit the enclosed quality plan, while submitting the bid.
- 1.6 The omission of specific reference to any component / accessory necessary for the proper performance of the equipments shall not relieve the supplier of the responsibility of providing such facilities to complete the supply within the quoted prices.
- 1.7 BHEL's / CUSTOMER'S representatives shall be given access to the shop in which the equipments are being manufactured or tested and all test records shall be made available to him.
- 1.8 The Equipment covered under this specification shall not be dispatched unless the same have been finally inspected, accepted and Material Dispatch Clearance Certificate (MDCC) is issued by BHEL / CUSTOMER.



**TECHNICAL SPECIFICATION FOR
AUXILIARY STEAM PRESSURE REDUCING &
DESUPERHEATING STATION**

SPEC. NO.: PE-TS-426-142-N101

SECTION 1

REV. NO. 00

DATE 13.01.20

PROJECT INFORMATION

CHAPTER 2 : GENERAL PROJECT INFORMATION**1.0 PROJECT INFORMATION**

1.1	Owner	:	UTTAR PRADESH RAJYA VIDYUT UTPADAN NIGAM LIMITED, LUCKNOW	
1.2	Project Title	:	Panki Thermal Power Station (1x660MW)	
1.3	Owner's Engineer	:	DEVELOPMENT CONSULTANTS PVT. LTD	
1.4	Project Site Location	:	Place	Panki
		:	District	Kanpur
		:	State	Uttar Pradesh
		:	Country	India
1.5	Latitude & Longitude of project site	:	North	N26 ⁰ 28'20"
		:	East	E 80 ⁰ 14'32"
1.6	Nearest Railway Station	:	Panki	5 km
1.7	Nearest Town	:	Kanpur	16km
1.8	Nearest Highway	:	National Highway - 25	
1.9	Nearest Airport	:	Kanpur	25 km
		:	Lucknow	80 Km
1.10	Nearest Commercial Airport	:	Delhi	140 km
1.11	Nearest Water Body	:	Lower Ganga Canal, adjacent to site	
1.12	Land	:	Land is in possession of UPRVUNL.	
1.13	Station Graded Level Elevation from Mean sea level (MSL)	:	Plant FGL → RL(+) 126.0M → EI(-) 0.500M Plant FFL → RL(+) 126.5M → EI(+/-) 0.000M	
1.14	Water	:		
1.14.1	Nearest Water Source	:	Lower Ganga Canal system running adjacent for project site	
1.14.2	Water Requirement for station	:	~ 1927 m ³ /hr considering closed cooling cycle with NDCT. Additional 700m ³ /hr for ash slurry preparation during emergency ash disposal to ash dyke.	
1.14.3	Raw Water Analysis from Upper Ganga Canal	:	Refer Appendix - I	
1.15	Site Ambient Condition	:		
1.15.1	Monthly mean (DBT)	:	Maximum	44.4 °C
		:	Minimum	3.8 °C
1.15.2	Extreme Recorded (DBT)	:	Maximum	47.3 °C
		:	Minimum	-0.9 °C
1.15.3	Monthly mean (WBT)	:	Maximum	27.3 °C
		:	Minimum	9.2 °C
1.15.4	Relative Humidity	:	Maximum	84 %
		:	Minimum	28 %
1.15.5	Average relative humidity	:	Annual Average	65 %
1.15.6	Rainfall	:	Annual average	832.6 mm



			Heaviest fall recorded in 24 hrs	247.4 mm
1.15.7	Basic Wind Speed	:	47.00 m/s	As per IS: 875 part - III
			For wind resistance design of structure & equipment refer relevant civil section	
1.15.8	Climatic condition	:	For detailed information refer attached Climatological data as published by IMD for Kanpur station.	
1.16	Seismic data	:	Zone - III	As per IS: 1893
			For earthquake resistance design of structure & equipment refer relevant civil section	
1.17	Fuel Data			
1.17.1	Coal Source	:	Coal requirement for this stage of the project is estimated as 2.99 million tones/annum considering 660 MW capacity, GCV of blended coal 4030 kcal/kg, Heat Rate as 2317 kcal/kwh and 90% PLF as per CERC operative norms effective from 1/4/2009.	
1.17.2	Coal Transportation	:	Thru BOXN wagons of Indian Railways System	
1.17.3	Coal Analysis	:	Refer Appendix - II	
1.17.4	Support Fuel (HFO / LDO) transportation	:	Support fuel will be transported by road tankers or by Railway system. Start-up / support fuel for the proposed project will be LDO/HFO.	
1.17.5	Support Fuel (HFO / LDO) analysis	:	Refer Appendix - II	



1 x 660 MW - Panki Thermal Power Station

Bidding Doc. No. : 14A14-SPC-G-0001





**TECHNICAL SPECIFICATION FOR
AUXILIARY STEAM PRESSURE REDUCING &
DESUPERHEATING STATION**

SPEC. NO.: PE-TS-426-142-N101

SECTION I

REV. NO. 00

DATE 22.01.20

SPECIFIC TECHNICAL REQUIREMENTS



**TECHNICAL SPECIFICATION FOR
AUXILIARY STEAM PRESSURE REDUCING &
DESUPERHEATING STATION**

SPEC. NO.: PE-TS-426-142-N101

SECTION I

REV. NO. 00

DATE 23.01.20

BRIEF SYSTEM DESCRIPTION

- 1.1 Auxiliary steam system is designed to provide steam for the turbine auxiliaries, boiler auxiliaries, fuel oil heating system during start-up, low loads and normal running of unit.
- 1.2 The system comprises of One "High capacity PRDS" with tapping from Main steam line to meet auxiliary steam requirements during unit start-up, low loads and the other "Low Capacity PRV" with tapping off steam from CRH line to meet auxiliary steam requirements during normal running. Spray water required for desuperheating will be tapped off from CEP discharge.
- 1.3 The HCPRDS will reduce the pressure and temperature of the steam tapped off from main steam line to 16 kg/cm² (abs) & 290°C. The LCPRV shall reduce the pressure of steam tapped from CRH line to 16 kg/cm² (abs) and temperature in the range of 280°C to 310°C, depending upon the CRH parameters at corresponding load.
- 1.4 APRDS system Comprises of:

S No	Description	Quantity/unit
1	Combined Type High Capacity Pressure Reducing & De-superheating Valve (On MS line)	1 no.
2	Low Capacity PRV (on CRH Line)	1 nos.
3	Spray Control Valve for HC-PRDS	2 no.

1.5 Spares, consumable and specified tools & tackles:

- i) Start-up, Commissioning spares and consumables shall be part of main package supply; however bidder to indicate prices separately. All such items shall be strictly interchangeable with the parts for which they are intended for replacements.
- ii) The bidder shall supply one complete set of special tools & tackles (if any) required for the erection, assembly, disassembly & maintenance of the equipment. A list of such tools & tackles to be supplied shall be submitted along with the bid.
- iii) Bidder to indicate the service life expectancy period for the spare parts under normal working conditions. The spares shall be treated and packed for long storage under climatic conditions prevailing at site. Small items shall be packed in sealed transparent plastic bags with desiccators' packs as necessary.
- iv) Commissioning Spares: As applicable for the project
(For Minimum requirement refer section II)

Stat-up & Commissioning spares:

- i) Start-up and Commissioning spares are those spares, which may be required during the start-up and commissioning of the Control Valves. All start-up spares, which are supplied under this contract, shall be strictly interchangeable with the parts for which they are intended for replacements.



**TECHNICAL SPECIFICATION FOR
AUXILIARY STEAM PRESSURE REDUCING &
DESUPERHEATING STATION**

SPEC. NO.: PE-TS-426-142-N101

SECTION I

REV. NO. 00

DATE 23.01.20

- ii) The Start-up and commissioning spares indicated by the bidder shall be a part of the main Control valves supply. However bidder to indicate prices separately. The list of these spares required to be supplied shall be submitted along with the bid.

v) **Mandatory Spares List:**

Auxiliary Steam Pressure Reducing & Desuperheating System

High Capacity PRDS System (i.e. for ASV-22)

1)	Desuperheater liners	1 set
2)	Steam pressure reducing cum desuperheating valves	
a)	Stem	1 no.
b)	Disc	1 no.
c)	Body Seat Rings	2 nos. for each type, size and rating of valves
d)	Gland Packing	2 nos. for each type, size and rating of valves
e)	Pressure Seal Ring	2 nos.
f)	gasket	2 nos.

For Spray Water Line Control Valve (i.e. for CDV-262 & 265)

a)	Valve trim (including cage, plug, stem, seat rings, guide bushings, stem packing etc.)	2 no. for each type, size and rating of valves
----	--	--

Low Capacity PRDS System (i.e for ASV-26)

Steam pressure reducing valve

	Stem	1 no.
	Disc	1 no.
	Body Seat Rings	2 nos. for each type, size
	Gland Packing	2 nos. for each type, size and rating of valves
	Pressure Seal Ring	3 nos.
	gasket	2 nos.



TECHNICAL SPECIFICATION FOR
AUXILIARY STEAM PRESSURE REDUCING &
DESUPERHEATING STATION

SPEC. NO.: PE-TS-426-142-N101

SECTION I

REV. NO. 00

DATE 23.01.20

SIZING DATA SHEET- A-1

COMBINED AUXILIARY STEAM PRDS & SPRAY CONTROL VALVE (ASV-22)

S.No.	Parameters	Cond.-1	Cond.-2	Cond.-3	Cond.-4	Cond.-5	Cond.-6	Mech. Design	
1.0	Inlet of Combined APRDS (ASV-22)								
1.1	Pressure (kg/cm ² (a))	70	95	110	145	270	120	295.8	
1.2	Temp. (°C)	320	475	445	550	593	465	601	
1.3	Flow (T/Hr)	Bidder To Calculate							
2.0	Outlet of combined APRDS (ASV-22)								
2.1	Pressure (kg/cm ² (a))	16	16	16	16	16	16	21	
2.2	Temp. (°C)	251	290	290	290	290	290	310	
2.3	Flow (T/Hr)	64.9	84.1	85.5	90.5	164.6	85	-	
3.0	Inlet of Spray Control Valve (CDV-262 & 265)								
3.1	Pressure (kg/cm ² (a))	42	42	40.2	40.2	38.5	40.2	51	
3.2	Temp. (°C)	36	36	37.1	37.1	44.5	37.1	60	
3.3	Flow (T/Hr)	BIDDER TO CALCULATE							

NOTE:

1. Cond.-1 is the capability check point for PRV ASV-22. Cond.-4 is the capability check point for Spray Water control valves.
2. Low capacity steam pressure reducing valve (i.e.ASV-26) at upstream parameters (60.61 kg.cm2(a), 344.7 0C) & downstream parameters (16 kg.cm2(a)) at 95% valve lift shall corresponds to passing capability of High capacity steam pressure reducing valve (i.e.ASV-22) at upstream parameters (247kg.cm2(a), 565 0C) & downstream parameters (16 kg.cm2(a), 290 0C) min. flow at 15% approx. valve lift.



**TECHNICAL SPECIFICATION FOR
AUXILIARY STEAM PRESSURE REDUCING &
DESUPERHEATING STATION**

SPEC. NO.: PE-TS-426-142-N101

SECTION I

REV. NO. 00

DATE 23.01.20

	Condition	VWO Flow (in T/Hr) at 100% Lift
CASE-1	Upstream pressure = 295.8 kgf/cm ² (a) Upstream temperature = 601 deg.C Downstream pressure = 21 kgf/cm ² (a)	
CASE-2	Upstream pressure = 270 kgf/cm ² (a) Upstream temperature = 593 deg.C Downstream pressure = 21 kgf/cm ² (a)	

SIZING DATA SHEET- A-2

AUXILIARY STEAM PRV (ASV-26)

S.No.	Parameters	Cond.-1	Cond.-2	Mech. Design
1.0	Inlet of PRV (ASV-26)			
1.1	Pressure (kg/cm ² (a))	24.4	58.5	74.1
1.2	Temp. (°C)	292.3	349.7	375
1.3	Flow (T/Hr)	10.60	28.60	-
2.0	Outlet of PRV (ASV-26)			
2.1	Pressure (kg/cm ² (a))	16	16	21
2.2	Temp. (°C)	Bidder To Calculate		
2.3	Flow (T/Hr)	10.60	28.60	-

Valve shall be sized for Auxiliary steam requirement of 30TPH for inlet parameters of condition- 2.



**TECHNICAL SPECIFICATION FOR
AUXILIARY STEAM PRESSURE REDUCING &
DESUPERHEATING STATION**

SPEC. NO.: PE-TS-426-142-N101

SECTION I

REV. NO. 00

DATE 23.01.20

DATA SHEETS- A

AUXILIARY STEAM PRESSURE REDUCING & DESUPERHEATING STATION



**TECHNICAL SPECIFICATION FOR
AUXILIARY STEAM PRESSURE REDUCING &
DESUPERHEATING STATION**

SPEC. NO.: PE-TS-426-142-N101

SECTION I

REV. NO. 00

DATE 23.01.20

Tag No.: **ASV-26** (LBG20AA101)

Qty.: **TWO PER UNIT**

Data Sheet No. PES-145-06-DS1-0

DATA SHEET – A & B

DATA SHEET – A FOR CONTROL VALVE (WITH PNEUMATIC ACTUATOR) (TO BE FILLED BY PURCHASER)		DATA SHEET – B (TO BE FILLED UP BY BIDDER)	
GENERAL*	PROJECT SERVICE	UPRVUNL - 1x6600 MW PANKI TPS COLD REHEAT STEAM TO AUXILIARY STEAM PR. REDUCING VALVE (LC PRV)	
	LOCATION DUTY	<input checked="" type="checkbox"/> INDOOR <input type="checkbox"/> OUTDOOR <input type="checkbox"/> ON/OFF <input checked="" type="checkbox"/> MODULATING	
BODY*	PIPE SIZE (inlet / outlet)	\varnothing 114.3x6.02 \varnothing 219.1 x 12.7 SA 106 Gr. C SA 106 Gr. C	
	PIPE MATERIAL (inlet / outlet)		
PNEUMATIC ACTUATOR	MODEL NO.	BIDDER TO SPECIFY	
	TYPE OF BODY: GUIDING : NO. OF PORTS	<input checked="" type="checkbox"/> GLOBE <input type="checkbox"/> ANGLE <input type="checkbox"/> TOP <input checked="" type="checkbox"/> CAGE ONE	
	BODY SIZE: PORT SIZE: DESIGN CV		
	END CONNECTION & RATING (ANSI)	<input checked="" type="checkbox"/> BWE <input type="checkbox"/> SWE <input type="checkbox"/> FLANGED <input type="checkbox"/> A216 WCC <input checked="" type="checkbox"/> A217 WC9 <input type="checkbox"/> SS <input type="checkbox"/> A217 C5 <input type="checkbox"/> A351 CF8M	
	BODY MATERIAL	<input type="checkbox"/> PTFE <input checked="" type="checkbox"/> GRAFOIL <input type="checkbox"/> DOUBLE <input checked="" type="checkbox"/> SINGLE <input type="checkbox"/> STD <input checked="" type="checkbox"/> EXTENDED <input type="checkbox"/> FINNED <input type="checkbox"/> LINEAR <input checked="" type="checkbox"/> EQ. PERCENTAGE <input type="checkbox"/> QUICK OPEN (ON/OFF)	
	PACKING: MATERIAL SINGLE / DOUBLE	SS316 (ST) SS316 (ST)	
	BONNET TYPE	SS316 (ST) SS316 (ST)	
	TRIM FORM	<input type="checkbox"/> BELOW SEAT <input type="checkbox"/> ABOVE SEAT <input type="checkbox"/> < 7 M/SEC (WATER) <input type="checkbox"/> MAC NO. < 1/2 (FLASHING) <input checked="" type="checkbox"/> < 150 M/SEC (STM)	
	TRIM MATERIAL: SEAT PLUG	<input type="checkbox"/> II <input type="checkbox"/> III <input type="checkbox"/> IV <input checked="" type="checkbox"/> V <input type="checkbox"/> VI LESS THAN 85 dBA (AT ONE METER DISTANCE)	
	: CAGE GUIDE BUSH	<input type="checkbox"/> YES <input checked="" type="checkbox"/> NO <input type="checkbox"/> YES <input checked="" type="checkbox"/> NO	
FLOW			
OUTLET VELOCITY			
REQUIRED LEAKAGE CLASS			
NOISE LEVEL (dBA)			
VACUUM SERVICE			
ANTI CAVITATION TRIM			
ACCESSORIES	MODEL NO. & SIZE	PNEUMATIC DOUBLE ACTING PISTON TYPE	
	CLOSE AT : OPEN AT (KG/CM2g)	1.0 0.2	
	*TRAVEL TIME FOR OPEN TO CLOSE AND CLOSE TO OPEN	LESS THAN 10 SECS.	
	*VALVE POSN. ON SIGNAL AIR FAILURE	<input checked="" type="checkbox"/> TO OPEN <input type="checkbox"/> STAYPUT <input type="checkbox"/> TO CLOSE	
*VALVE POSN. ON SUPPLY AIR FAILURE	<input checked="" type="checkbox"/> STAYPUT		
ACCESSORIES	POSITIONER (SMART)	<input checked="" type="checkbox"/> REQUIRED <input type="checkbox"/> NOT REQUIRED	
	AIR FILTER REGULATOR	<input checked="" type="checkbox"/> REQUIRED <input type="checkbox"/> NOT REQUIRED	
	AIR LOCK RELAY	<input checked="" type="checkbox"/> REQUIRED <input type="checkbox"/> NOT REQUIRED	
	POSITION LIMIT SWITCH	<input checked="" type="checkbox"/> REQUIRED <input type="checkbox"/> NOT REQUIRED	
	POSITION TRANSMITTER	PART OF SMART POSITIONER	
	SOLENOID VALVE	<input checked="" type="checkbox"/> REQUIRED <input type="checkbox"/> NOT REQUIRED	
	E/P CONVERTOR	PART OF SMART POSITIONER	
	JUNCTION BOX	<input checked="" type="checkbox"/> REQUIRED <input type="checkbox"/> NOT REQUIRED	
	HAND WHEEL (SIDE MOUNTED)	<input checked="" type="checkbox"/> REQUIRED	
	LOCAL POSITION INDICATOR	<input checked="" type="checkbox"/> REQUIRED	

	TECHNICAL SPECIFICATION FOR AUXILIARY STEAM PRESSURE REDUCING & DESUPERHEATING STATION		SPEC. NO.: PE-TS-426-142-N101	
			SECTION I	
			REV. NO. 00	DATE 23.01.20

Tag No.: **ASV-26**

Qty.: **ONE PER UNIT**
DATA SHEET – A & B

Data Sheet No. PES-145-06-DS1-0

DATA SHEET – A FOR CONTROL VALVE (WITH PNEUMATIC ACTUATOR) (TO BE FILLED BY PURCHASER)								DATA SHEET – B (TO BE FILLED UP BY BIDDER)		
PERFORMANCE OF VALVE	LINEARITY			± 1%					
	HYSTERESIS			± 1%					
PERFORMANCE OF VALVE	SENSITIVITY			± 0.5%					
	ACCURACY (OVERALL)			± 1%					
SERVICE CONDITION*	SL. No. +	LOAD	FLOW (T/HR)	INLET PR. KG/CM2(A)	OUTLET PR. KG/CM2(A)	TEMP DEG (C)	CALCULATED CV	% VALVE LIFT	VALVE O/L VELOCITY	
	Refer Sizing Data for Low Capacity PRV									
	VALVE TYPE							<input type="checkbox"/> CAVITATION <input type="checkbox"/> FLASHING <input checked="" type="checkbox"/> HIGH DP		
	* MAX SHUT OFF PRESS (KG/CM2(A)					74.1			
BODY DESIGN : PRESS (KG/CM2(A) TEMP (DEG C)					74.1 375				
* IBR FORM III-C					<input checked="" type="checkbox"/> REQUIRED <input type="checkbox"/> NOT REQUIRED				
TOTAL WEIGHT (VALVE + ACTUATOR + ACCESSORIES) Kg									
<p>Note:</p> <ol style="list-style-type: none"> Valve actuators shall be capable of operating at 70 Degree C ambient continuously. The design of all valve bodies shall conform to the requirements of ANSI (USA) for dimensions, material thickness and material specification for their respective pressure classes. Separate moisture separator unit for ensuring dryness of air entering I/P is to be supplied with each control valve. SS name plate shall be fixed on the control valve and it will have all details like KKS Tag no. / SI. No. / Body material size / Press. Rating / Trim material / Trim type / action on air failure / diaphragm air pressure at full open and closed condition 										



Control Valves Accessories
(Pneumatically Operated)

DOCUMENT NO: PE-TS-145-I104	
DOCUMENT NO.:	
VOLUME	
SECTION	
REV. NO. 01	DATE: 20.11.2017
SHEET 48 OF 55	

Tag No.....		Quantity.....		Data Sheet No. PES-145-06-DS1-1		
APPLICABLE FOR TAG Nos.WHEREVER STATEMENT "REQUIRED" INDICATED IN THE INDIVIDUAL CV DATA SHEETS						
DATA SHEET – A & B for ACCESSORIES						
DATA SHEET – A FOR CONTROL VALVE (WITH PNEUMATIC ACTUATOR) (TO BE FILLED BY PURCHASER)				DATA SHEET – B (TO BE FILLED-UP BY BIDDER)		
POSITIONER	MFR. & MODEL NUMBER			<input type="checkbox"/> YES <input checked="" type="checkbox"/> NO	<input checked="" type="checkbox"/> TWO OR THREE (AS PER HOOK-UP)	<input checked="" type="checkbox"/> IP-65
	BYPASS	GAUGES	ENCL. CLASS			
	INPUT SIGNAL (Kg / Cm ²)			<input checked="" type="checkbox"/> 0.2 – 1.0 4-20 mA HART COMPATIBLE		
	OUTPUT SIGNAL (Kg / Cm ²)			TO SUIT ACTUATOR		
AIR FILTER REGULATOR	MFR. & MODEL NUMBER					
	AIR SUPPLY PRESS (Kg / Cm ² g)			<input checked="" type="checkbox"/> 5.0 – 8.0 <input type="checkbox"/>		
	OUTPUT PRESS (Kg / Cm ² g)			TO SUIT ACTUATOR		
	FILTER SIZE			5 MICRON		
	OUTPUT GAUGE			<input checked="" type="checkbox"/> REQUIRED <input type="checkbox"/> NOT REQUIRED		
AUTO DRAIN FEATURE			<input checked="" type="checkbox"/> REQUIRED <input type="checkbox"/> NOT REQUIRED			
AIR LOCK	MFR. & MODEL NUMBER					
	SET PRESS (Kg / Cm ²)					
	SUPPLY PRESS (Kg / Cm ²)			<input checked="" type="checkbox"/> 5.0 – 8.0 <input type="checkbox"/>		
	RESET TYPE			AUTO		
	VENT PLUG			REQUIRED		
LIMIT SWITCH	MFR. & MODEL NUMBER					
	OPEN posn	INT posn	CLOSE posn	2 NO.	---	2 NO.
	CONTACT TYPE			SPDT 2 NO + 2 NC		
	RATING (AC / DC)			5A 240V AC AND 0.5A 220V DC		
	ENCLOSURE CLASS			<input checked="" type="checkbox"/> IP 65 <input type="checkbox"/>		
POSITION TRANSMITTER	MFR. & MODEL NUMBER			PART OF SMART POSITIONER		
	TYPE					
	SUPPLY					
	OUTPUT RATING					
	ACCURACY					
	ENCLOSURE CLASS					
SOLENOID VALVE	MFR. & MODEL NUMBER					
	RATING			<input checked="" type="checkbox"/> 24V DC <input type="checkbox"/> 220V DC <input type="checkbox"/> 240V AC <input type="checkbox"/>		
	TYPE			3-WAY (UNIVERSAL OPERATION TYPE)		
	OPERATION	QUANTITY		<input type="checkbox"/> Stayput <input type="checkbox"/> Interlock <input type="checkbox"/> 1 <input type="checkbox"/> 2		
	COIL INSULATION CLASS			CLASS - H		
ENCLOSURE CLASS			<input checked="" type="checkbox"/> IP 65 <input type="checkbox"/> NEMA 4 <input type="checkbox"/>			
HANDWHEEL	ORIENTATION			<input type="checkbox"/> TOP MOUNTED <input checked="" type="checkbox"/> SIDE MOUNTED		
JUNCTION BOX	NO. OF WAYS			<input type="checkbox"/> 24-WAYS <input type="checkbox"/> AS REQUIRED <input checked="" type="checkbox"/> 36-Ways		
	SIZE			AS REQUIRED		
	CABLE GLANDS (Size / Quantity)			AS REQUIRED (Double Compression Type).		
	ENCLOSURE CLASS			<input checked="" type="checkbox"/> IP 65 <input type="checkbox"/>		
	BODY MATERIAL			<input checked="" type="checkbox"/> FRP <input type="checkbox"/> SS <input type="checkbox"/> METAL SHEET		
IP CONVERTER	INPUT SIGNAL	POWER SUPPLY		PART OF SMART POSITIONER		
	SPLIT RANGE					
	ENCLOSURE CLASS					
	LINEARITY					
	HYSTERISIS					
Cu./SS Tubing & Fittings / per CV	This is in addition to cu. Tubing and fittings which are integral part of CV			12 Meters of ¼ " SS 316 Tubing, with 1 set of Fittings for each CV for connection to IA Header on one end and accessories on another end of CV.		
PAINTING	COLOUR/SHADE			<input checked="" type="checkbox"/> RED <input type="checkbox"/> GREEN <input type="checkbox"/>		
	THICKNESS (DFT) – in microns					
	TYPE			<input checked="" type="checkbox"/> EPOXY <input type="checkbox"/> ENAMEL <input type="checkbox"/>		
						COMPANY SEAL
						NAME
						SIGNATURE

ANNEXURE-1

Air Filter Regulator (AFR)

Constant bleed type AFR with an accuracy of + 1.0 % inlet pressure range of 5-10 kg/ cm² and suitable spring ranges (AFR) for use with positioners in control valves, control damper, E/P convertors and shut off valves with sintered phosphor bronze filter element; Filtering particles above five microns. IP 65 Weather and water proof enclosure. Material of accessories will be SS316. Body material of filter regulator shall be Die Cast Aluminum or SS316

Solenoid Valves

Solenoid Valve coils insulation class shall be Class-H high-temperature or Class-F construction as applicable and shall be designed for continuous duty. Three-way solenoid valves shall be designed for universal operation so that the supply air may be connected to any port. Solenoid enclosures shall be NEMA-4/ (Explosion proof for NEC Class-1/2, Division 1 area)/ flame proof (IEC-79.1, Part I) as applicable). Body material of solenoid valve shall be Brass or SS316 with epoxy paint as decided during engineering by owner. Material of wetted parts shall be SS316 only. Leakage class shall be class VI (Bubble tight)

Air locks

Air locks shall be designed to shut off the diaphragm loading air line if the supply air pressure to the associated pilot or Positioner fails. Air locks shall be of the automatic reset type and shall be furnished with alarms.

Hand Wheels

Hand Wheels shall be provided. Hand wheels shall be side mounted unless specified to be top mounted. However the mounting shall be as decided during engineering to offer maximum accessibility.

Limit Switches

Each control Valves shall be provided with limit switches for monitoring of end position in DDCMIS/DCS/PLC. Switches shall have not less than two normally open and two normally closed contacts in both open and close directions. Electrical rating of the limit switch contacts shall be 240V AC, 5 amp or 220V DC, 0.5 amp. Limit switches should be National Acme Co., or Honeywell micro switch type or Owner approved equal. The enclosures of the limit switches shall be as per NEMA-4 Standard. Limit switches shall be constructed to withstand the temperatures encountered in the actual service. Explosion proof construction shall be furnished where required by applicable code or these specifications. Limit switches shall be factory mounted on the valves with provisions for adjusting the mounting. The Bidder shall stroke the valves to check limit switch operation prior to shipment. Limit/micro switches can be offered as an integral part of Smart valve positioner.

Tubing and Air Sets

All pneumatic tubing required to interconnect devices assembled together shall be furnished complete with each control valve. The tubing shall be fully annealed soft temper copper/SS316 tubing conforming to ASTM B68 to B75 (USA). Swage lock flare less tubing fittings shall be used for tubing connections (Swage lock or approved equal).

Smart Valve Positioner

Control valve actuators for modulating and throttling services shall be provided with HART protocol based smart electro pneumatic valve Positioner to ensure accuracy & repeatability of response. The valve Positioner shall be designed suitable for vibration and service conditions of a steam electric power station.

The Positioner shall have the following features:

- a) Shall provide a pneumatic output signal of range 0.2 to 1.0 kg/cm² or as desired for the actuator.
- b) Shall have integral type position transmitter, input & output gauges, local keypad, display, 4-20 mA input and 4-20 mA output for position indication in DDCMIS/CCR/PLC. Compatibility for Remote Calibration & Diagnostic (Super imposed HART signal on input signal (4-20mA). 1 no. digital input shall be provided to control system for fault diagnostic.
- c) Shall be suitable for direct mounting on control valve assembly both for rotary & linear valves.
- d) Shall be capable of functioning under hot, humid & vibrating conditions.
- e) Shall have dust tight, corrosion resistant & weather proof IP 65 metal (Die Cast Aluminium/SS316) casing.
- f) Shall be operated at signal range of 4-20 mA for full travel of the valve. Split range operation in few case may be required. This facility shall also be available in positioner.
- g) Shall have in built mechanical position indicator.
- h) Shall have fail safe & fail freeze function as per loop process requirement. (In case the fail freeze feature is not intrinsic to the positioner, Bidder shall achieve the same externally through solenoid valve connected in the pneumatic circuit).
- i) Shall have in built auto tune facility.
- j) In built advanced diagnostic/ test feature like stroke counter or travel counter, leakage in actuator, valve signature analysis, Step response time, valve friction/Jamming detection etc to be provided.
- k) Window based software. Software shall meet the requirements for configuration, diagnostic, calibration and testing of the actuator.
- l) Remote & Local Calibration, Auto & manual Calibration shall be provided.
- m) EMC & CE Compliance – EN 50081-2 & EN 50082 or equivalent.



**TECHNICAL SPECIFICATION FOR
AUXILIARY STEAM PRESSURE REDUCING &
DESUPERHEATING STATION**

SPECIFICATION NO.: PE-TS-426-N101

SECTION I

REV. NO. 00

DATE : 13.01.20

CUSTOMER SPECIFICATION

CHAPTER –11: CONTROL VALVES WITH ACTUATORS**11.01.00 CONTROL VALVES, ACTUATORS & ACCESSORIES****11.01.00 General Requirements**

- 11.01.01 The control valves and accessories equipment furnished by the Bidder shall be designed, constructed and tested in accordance with the latest applicable requirements of code for pressure piping ANSI B 31.1, the ASME Boiler & pressure vessel code, Indian Boiler Regulation (IBR), ISA, and other standards specified elsewhere as well as in accordance with all applicable requirements of the "Federal Occupational Safety and Health Standards, USA" or acceptable equal standards. All the Control Valves, their actuators and accessories to be furnished under this Sub-section will be fully suitable and compatible with the modulating loops covered under the Specification.
- 11.01.02 All the control valves and accessories offered by the Bidder shall be from reputed, experienced manufacturers of specified type and range of valves.
- 11.01.03 For special type of control valves such as combined pressure and temperature control valves for Aux PRDS application, separator drain control valves, also refer to the corresponding mechanical sections.

11.02.00 CONTROL VALVE SIZING & CONSTRUCTION

- 11.02.01 The design of all valve bodies shall meet the specification requirements and shall conform to the requirements of ANSI (USA) for dimensions, material thickness and material specification for their respective pressure classes.
- 11.02.02 The valve sizing shall be suitable for obtaining maximum flow conditions with valve opening at approximately 80% of total valve stem travel and minimum flow conditions with valve stem travel not less than 10% of total valve stem travel. All the valves shall be capable of handling at least 120% of the required maximum flow. Further, the valve stem travel range from minimum flow condition to maximum flow condition shall not be less than 50% of the total valve stem travel. The sizing shall be in accordance with the latest edition of ISA handbook on control valves. While deciding the size of valves, Bidder shall ensure that valves trim exit outlet velocity as defined in ISA handbook does not exceed 8 m/sec for liquid services, 150 m/sec. for steam services and 50% of sonic velocity for flashing services. Bidder shall furnish the sizing calculations clearly indicating the outlet velocity achieved with the valve size selected by him as well as noise calculations, which will be subject to Owner's approval during detailed engineering.
- 11.02.03 Control valves for steam and water applications shall be designed to prevent cavitation, wire drawing, flashing on the downstream side of valve and downstream piping. Thus for cavitation/flashing service, only valve with anti cavitations trim shall be provided. Detailed calculations to establish whether cavitation will occur or not for any given application shall be furnished.



- 11.02.05 The control valve induced noise shall be limited to 85 dba at 1 meter from the valve surface under actual operating conditions. The noise abatement shall be achieved by valve body and trim design and not by use of silencers.
- 11.02.06 The Liquid pressure recovery factor (FL) shall be 0.995 or better for severe flashing/cavitation services.
- 11.02.07 The Liquid pressure recovery factor (FL) shall be 0.985 or better for low flashing/cavitation services.
- 11.02.08 The valve travel time shall be less than 10 second for non critical services valves.
- 11.02.09 Rangeability should be 50 to 1 (min.) for non critical services valves.
- 11.02.10 Modulating Type Control Valve's Linearity, Hysteresis, Accuracy shall be < +1% and Sensitivity shall be < + 0.5%.

11.03.00 VALVE CONSTRUCTION

- 11.03.01 All valves shall be of globe body design & straightaway pattern with single or double port, unless other wise specified or recommended by the manufacturer to be of angle body type. Rotary valve may alternatively be offered when pressure and pressure drops permit.
- 11.03.02 Valves with high lift cage guided plugs & quick-change trims shall be supplied.
- 11.03.03 Cast Iron valves are not acceptable.
- 11.03.04 Bonnet joints for all control valves shall be of the flanged and bolted type or other construction acceptable to the Owner. Bonnet joints of the internal threaded or union type will not be acceptable.
- 11.03.05 Plug shall be of one-piece construction cast, forged or machined from solid bar stock. Plug shall be screwed and pinned to valve stems or shall be integral with the valve stems.
- 11.03.06 All valves connected to vacuum on down stream side shall be provided with packing suitable for vacuum applications (e.g. double vee type chevron packing)
- 11.03.07 Valve characteristic shall match with the process characteristics.
- 11.03.08 Extension bonnets shall be provided when the maximum temperature of flowing fluid is greater than 280 deg. C.
- 11.03.09 Flanged valves shall be rated at no less then ANSI press class of 300 lbs.

NOTE Valve body rating shall meet the process pressure and temperature requirement as per ANSI B16.34.

However, Bidder may offer valves with body and trim materials better than specified materials and in such cases Bidder shall furnish the comparison of properties including cavitation resistance, hardness, tensile strength, strain energy, corrosion resistance and erosion resistance etc. of the offered material vis-a-vis the specified material for Owner's consideration and approval.

11.05.00 END PREPARATION

Valve body ends shall be either butt welded/socket welded, flanged (Rubber lined for condensate service) or screwed as finalized during detailed engineering and as per Owner's approval. The welded ends wherever required shall be butt welded type as per ANSI B 16.25 for control valves of sizes 65 mm and above. For valves size 50 mm and below welded ends shall be socket welded as per ANSI B 16.11. Flanged ends wherever required shall be of ANSI pressure-temperature class equal to or greater than that of the control valve body.

11.06.00 VALVE ACTUATORS

All control valves shall be furnished with pneumatic actuators except for pressure and temperature control valve for auxiliary PRDS application (Electro-hydraulic / pneumatically operated) and HP & LP bypass valves, separator drain control valve (Electro-hydraulic type). The Bidder shall be responsible for proper selection and sizing of valve actuators in accordance with the pressure drop and maximum shut off pressure and leakage class requirements. The valve actuators shall be capable of operating at 60 deg.C continuously.

Valve actuators and stems shall be adequate to handle the unbalanced forces occurring under the specified flow conditions or the maximum differential pressure specified. An adequate allowance for stem force, at least 0.15 Kg/sq.cm. per linear millimeter of seating surface, shall be provided in the



selection of the actuator to ensure tight seating unless otherwise specified.

The travel time of the pneumatic actuators shall not exceed 10 seconds.

11.07.00 CONTROL VALVE ACCESSORY DEVICES

11.07.01 All pneumatic actuated control valve accessories such as air locks, hand wheels/hand-jacks, limit switches, microprocessor based electronic Positioner, diffusers, external volume chambers, position transmitters (capacitance or resistance type only), reversible pilot for Positioner, tubing and air sets, solenoid valves and junction boxes etc. shall be provided as per the requirements.

11.08.00 SPECIFICATIONS FOR MICROPROCESSOR BASED ELECTRONIC POSITIONER

1	Electrical	a) Input Demand Signal	4-20 mA
		b) Power Supply	Loop Powered from the output card of Control System.
		c) HART Protocol	Compatibility for Remote Calibration & Diagnostics (Super-imposed HART signal on input Signal (4-20 mA))
		d. Valve position sensing	Position sensing, 4-20 mA output signal to be provided for control system.
2	Environment	a) Operating temp.	(-)30 To 80 Deg. C
		b) Humidity	0-95 %
		c) Protection class	IP-65 Minimum with Die cast Aluminum/SS316 enclosure.
3	Software for Configuration and Diagnostics	Software	Windows based software. Software shall meet the requirements for Configuration, Diagnostics, Calibration and Testing of the actuator.
		Diagnostic/Test features	Advanced diagnostic features like Stroke counter or Travel counter, Leakage in actuators, Valve Signature analysis, Step Response test, Valve friction /Jamming detection etc. to be provided.

4	Test reports/ Certificates	Factory Valve Signature Tests Reports (Pressure versus Valve travel and Travel versus I/P signal) are to be provided.	
		Test certificates as per Manufacture Standard/Relevant Standard are to be submitted.	
5	Configurat ion/ Calibration	Remote & Local Calibration, Auto & Manual Calibration shall be possible.	
6	Operating Range	Full range/ Split range.	
7	Modes	Valve Action	Direct / Reverse Valve Action
		Flow Characterization	Possible to fit Valve Characteristic Curves- Linear , Equal percentage etc.
8	Fail Safe/Fail Freeze	Fail Safe/Fail Freeze feature is to be provided. (In case the fail freeze feature is not intrinsic to the positioner, Bidder shall achieve the same externally through solenoid valve connected in the pneumatic circuit).	
9	Pneumatic	Air capacity	Sufficient to handle the valves & actuators selected/ Boosters to be supplied, if required.
		Air pressure	To suit the air supply pressure/quality available.
		Process connection	¼" NPT
10	Performance	Characteristic deviation	≤ 0.5 % of span.
		Ambient temp effect	≤ 0.01 %/ deg C or better.
11	EMC & CE compliance	Required to International Standard like EN/IEC.	EN50081-2 & EN 50082 or equivalent.

12	Accessories	In-built Operator Panel	Display with push buttons for configuration and display on the positioner itself (Password protected/Hardware lock).
		Hand Held Hart Calibrator	Universal Hart Calibrator to be provided (for quantity, refer Part-A Vol-V C&I :).
		Pressure Gauge Block & Position Indicators.	For supply & output pressures, Air Filter Regulator, integral type position transmitter, in built mechanical position indicator and other accessories shall be provided on as required basis for making system complete.
		Electrical Cable Entry	1/2" NPT, side or bottom entry to avoid water ingress.
		Valves Mounting Assembly	For Sliding Stem/Rotary/Single acting/Double acting actuators on as required basis.

*** Note:**

The HART signals shall be picked up from marshalling terminals of DDCMIS (SG/TG DDCMIS as well as BOP DDCMIS), as applicable. The details of the above mentioned HART management system specification are mentioned in HART system Vol-V, Part B, Chapter 3, DDCMIS, cl. no. 3.45.00

The positioners shall be monitored from this HART management system .To achieve this, Bidder shall provide the necessary software to achieve the functionalities described above under "Remote Configuration and Diagnostics", and this software shall be loaded in the HART management system.

11.09.01 General Requirements for Critical Application Control Valves -

- i) The valve accessories shall include hand wheels, limit switches, smart valve positioner (4-20mA DC type), electro pneumatic converter, Air lock relay, Solenoid valve and all other items required for the completeness and the accessories shall be explosion proof type as per hazardous area classification wherever applicable.
- ii) Control valves shall be furnished with IBR certification wherever required.

1. **Noise:** The maximum allowable noise level shall be 85 dba or less at 1 m. distance from the downstream bare pipe surface. The specified noise level shall be attained without the use of orifices, mufflers, diffusers. No credit for thermal or acoustical insulations shall be taken.
2. **Valve Trim:** Valve shall have quick change type trim utilizing top entry. No components shall be screwed or welded into the body. The valve shall have equal pressure distribution around the plug to avoid chattering / vibration.

Trim of severe/critical service valve shall be of multi stage & multi path design with sufficient no. of discrete pressure drop stage to eliminate the chance of erosion, cavitations, noise, vibration through out the control range of valve.

3. **Leakage Class:** The valve shall have minimum class-V leakage for all steam applications including RH/SH, APRDS, Soot Blower control valve, HP/LP Bypass spray control valves, BFP minimum recirculation valve & Low Load feed water control valve.

In case of HP/LP Bypass control valve application, the leakage class should be MSS-SP 61 (block valve leakage).

4. **Actuator:** Actuator type should be pneumatic double acting piston/electro-Hydraulic.

11.10.00 TEST AND EXAMINATION

All valves shall be tested in accordance with the quality assurance program agreed between the Owner and Contractor, which shall meet the requirements of IBR and other applicable codes mentioned elsewhere in the specifications. The tests shall include but not be limited to the following:

- 11.10.01 Non Destructive Test as per ANSI B-16.34.
- 11.10.02 Hydrostatic shell test in accordance with ANSI B 16.34 prior to seat leakage test.
- 11.10.03 Valve closure test and seat leakage test in accordance with ANSI-B 16.34 and as per the leakage class indicated above.
- 11.10.04 Functional Test: The fully assembled valves including actuators control devices



and accessories shall be functionally tested to demonstrate times from open to close position.



1 x 660 MW - Panki Thermal Power Station

Bidding Doc. No. : 14A14-SPC-G-0001



9.08.00 Field Mounted Local Junction Boxes

Type of Enclosure	:	Flame proof/weather proof IP-65 /Explosion Proof as per area classification. Design as per NEC-370 Article 18, 19 & 20.
No. of Ways	:	12/24/36/48/64/72/96/128 with 20% spares terminals.
Material	:	4 mm min. thick FRP (Fiberglass Reinforced Polyester) with protective Coating
		3 mm min. thickness Die cast aluminum for Flame proof/Explosion proof area.
Cable entry	:	Bottom or Side
Cable glands	:	Double compression type – Nickel plated Brass/SS316 with PVC hoods.
Mounting	:	Indoor/Outdoor
No. of terminals	:	As required with standardization with 20% spare of each size & type.
Terminals	:	Phoenix/Wago (screw less rail mounted cage clamp type spring loaded suitable for conductor size up to 2.5 sq. mm)
Grounding	:	Two terminals for body and shield ground
Door	:	Hinged, lockable type.
Accessories	:	Suitable mounting clamps and other accessories shall be in scope of bidder. The brackets, bolts, nuts, screws, glands, lugs required for erection shall be of SS304, included in bidder scope of supply. High voltage & insulation resistance test shall also be conducted.

M6 Ni plated Brass earthing stud shall be provided (external 2 nos. internal 1 no.)
Gasket (Normal)- Neoprene/Polyurethane thickness 6.0 mm. Silicon for high Temp. area.

Colour : To be decided during detailed engineering & subject to owner's approval.

2.11.01 Air Filter Regulator (AFR)

Constant bleed type AFR with an accuracy of ± 1.0 % inlet pressure range of 5-8 kg/ cm² and suitable spring ranges (AFR) for use with positioners in control valves, control damper, E/P convertors and shut off valves with phosphor bronze sintered filter element; Filtering particles above five microns. Weather and water proof enclosure. Built in blow down valve shall be provided. AFR shall have automatic drain feature. Material of accessories will be SS316. Body material of Air Filter regulator shall be Die Cast Aluminum or SS316. Degree of protection shall be IP 65.

Air filter regulators shall be provided in the :

- (a) Air supply line to valve positioners / power cylinders.
- (b) Air supply line to electric to pneumatic convertors.



1 x 660 MW - Panki Thermal Power Station

Bidding Doc. No. : 14A14-SPC-G-0001



Accessories : Counter flange, Cable gland, prefab cable and stainless steel name plate engraved with alpha-numeric.

2.14.00 SOLENOID VALVES

Solenoid valves shall fulfill the following requirements:



1 x 660 MW - Panki Thermal Power Station

Bidding Doc. No. : 14A14-SPC-G-0001



- a. Type 2/3/4 way with body material of SS 316/Forged Brass and epoxy painting (depending on the application subject to Owner's approval during detailed Engg.). Material of Wetted parts shall be SS316.
- b. Power supply 24 V DC + 10%.
- c. Plug and socket electrical connection.
- d. Insulation: Class 'H'.
- e. All solenoid shall be with, LED indication, surge suppression diode circuits.

2.15.00 Power Cylinders (Pneumatic)

Mounting Type	:	a) Fixed position mounting (End mounting). b) Trunnion mounting
Control Signal	:	0.2 to 1 Kg/Sq. cm. from I/P converter for modulating purposes. 24V/48VDC operated solenoid valve operating on pneumatic line. The Pilot solenoid will have separate coils for open closing purpose.
Supply Air	:	0-7 Kg / Cm ² .
Selection	:	Based upon thrust / torque, stroke length, angular movement, full-scale travel time, repeatability, space factor etc. Provision for air-to-open and air-to-close operation.
Casing	:	IP-65.
Accessories (as required)	:	a) Air lock relay b) Hand wheel. c) Air filter regulator with gauge. d) Volume Booster. e) Limit Switches. f) Positioner with Input, Output and supply pressure gauges. g) Pilot Solenoid Valve (Double Coil type) h) Position Transmitter (4-20 mA DC linear output, LVDT or non contact type).
Fail-safe operation	:	Stay put, open or close position on pneumatic / electrical power supply failure as per process safety criteria.
Repeatability	:	Better than 0.5% of full travel.



1 x 660 MW - Panki Thermal Power Station

Bidding Doc. No. : 14A14-SPC-G-0001



Hysteresis : Less than $\pm 1\%$ of full travel.



1 x 660 MW - Panki Thermal Power Station

Bidding Doc. No. : 14A14-SPC-G-0001



2.18.00 Limit switches

For offsite plant application Limit switches shall be gold plated with high conductivity and non corrosive type. Contact rating shall be sufficient to meet the requirement of DDCMIS subject to a minimum of 60 V, 6 VA rating. Protection class shall be IP 65. Contact shall be either 1 no, DPDT or 2 nos. SPDT minimum.

For main plant application, limit switches are to be provided as per bidder standard and proven practice.

All limit switch shall be conform to IEC-60947-5-1.



1 x 660 MW - Panki Thermal Power Station

Bidding Doc. No. : 14A14-SPC-G-0001



- (c) Air supply line to pneumatic interlocked block valves.
- (d) For each instrument rack, field instruments enclosure for purging.

2.11.02 E-P CONVERTER

E-P converters and associated accessories shall be furnished in accordance with the specifications given below:

Air supply: 1.5 kg/cm sq., Input signal: 4-20m A dc (as required by the design of control system), Output signal: 0.2 to 1.0 kg/cm sq., Linearity: 0.5% of span or better, Hysteresis:0.5% of span or better, Ambient Temperature Effect: less than 0.02% of span per deg C between -20 to +60 deg C. Mounting: Close to actuator (but not on the actuator), output capacity-to suit the actuator, protection class IP 65. On loss of control signal, the last set point pressure shall be maintained so that the associated control valve remains in stay put condition without any additional solenoid valve. The allowable drift rate will be +2% of set point/ hour maximum. Material of accessories will be SS. E/P convertors shall have fail freeze (stay put) feature also. Zero/span adjustment facility shall be provided.



1 x 660 MW - Panki Thermal Power Station

Bidding Doc. No. : 14A14-SPC-G-0001





**TECHNICAL SPECIFICATION FOR
AUXILIARY STEAM PRESSURE REDUCING &
DESUPERHEATING STATION**

SPEC. NO.: PE-TS-426-142-N101

SECTION II

REV. NO. 00

DATE 13.01.20

SPECIFICATION FOR APRDS



**TECHNICAL SPECIFICATION FOR
AUXILIARY STEAM PRESSURE REDUCING &
DESUPERHEATING STATION**

SPEC. NO.: PE-TS-426-142-N101

SECTION II

REV. NO. 00

DATE 13.01.20

1.0 SCOPE

- 1.1 This specification covers the Design, Manufacture, Inspection and Testing at the manufacturer's works, proper packing for transportation and delivery to site of AUXILIARY STEAM PRESSURE REDUCING & DESUPERHEATING STATION (with Pneumatic Actuator) for use in Utility/Captive Power Station.
- 1.2 Expander/Reducer between valve body & pipe shall be in BHEL's scope of supply. However, any other expander/reducer required shall be in bidder's scope of supply.

2.0 CODES AND STANDARDS

- 2.1 As a minimum requirement, the latest revision/version of the following or equivalent standards shall be complied as a minimum requirement: -

Indian Boiler Regulation	:	IBR
ASME	:	B31.1/BPVC
Allowable Seat leakage	:	FCI-70.2
Pressure & Temperature ratings	:	ANSI-B16.34
Enclosure class	:	IEC-144 / NEMA / IS-13947
Control Valves Sizing	:	ISA S-75

3.0 TECHNICAL REQUIREMENTS

The Control valve, Actuator and the accessories shall be suitable for continuous operation under an ambient temperature of 0-60°C and Relative Humidity of 0-95% unless specified otherwise in Section-I.

3.1 Control Valve

The control valve shall be suitably designed for the process operating conditions and system characteristics as specified in the Data Sheet-A.

- 3.1.1 The control valve shall be of globe/angle body design, as per datasheet, with single port. Valve trim shall be cage guided balanced type for valve sizes $\geq 3''$ and above. The valve trim shall be suitable for quick replacement without any cutting or welding. Anti-cavitation trims shall be provided for valves with cavitation service and hardened trims for flashing services.
- 3.1.2 Bidder to note that High Capacity PRDS is a combined type steam conditioning valve with single valve body design. Bidder to offer body and trim materials as per the datasheet-A. Wherever there is a deviation from the datasheets, bidder to furnish the documentary proof for confirming superior trim material/body material selection along with their offer. BHEL/ Customer reserves the right to accept/reject any variation in the specification.
- 3.1.3 Asbestos shall not be used for the packing or any other component.
- 3.1.4 The valve bonnet and packing shall be suitable for the service conditions as in Data Sheet-A. Gland sealed type bonnets are not acceptable. Bonnets having Teflon packing shall have valve stem finished to



**TECHNICAL SPECIFICATION FOR
AUXILIARY STEAM PRESSURE REDUCING &
DESUPERHEATING STATION**

SPEC. NO.: PE-TS-426-142-N101

SECTION II

REV. NO. 00

DATE 13.01.20

2-4 micro inches RMS. Packing material requiring lubrication will not be acceptable.

Type of bonnet shall be according to the service condition. Extension bonnets shall be provided when the maximum temperature of the flowing fluid is greater than 280 or unless otherwise specified.

3.1.5 The valve end connection as specified in Data Sheet-A shall conform to ANSI B16.25 for Butt Weld connection and ANSI B16.11 for socket weld connection. Tolerances on end to end, center to center, center to face shall be in accordance with ASME B16.10. The end connections shall be Socket Welded for sizes below 50NB and Butt Welded for sizes 50NB and above.

3.1.6 The valve seat leakage shall be as per FCI-70.2. The leakage class shall be as per Data Sheet-A.

3.1.7 The valve body shall have the direction of flow embossed on all valves.

3.1.8 The sizing shall conform to the requirements of ISA S75.01. Valve shall be capable of handling 120% of required maximum flow with meeting below mentioned requirements:

Valve with Linear characteristic.	-	Normal Flow (Design Point)	:	70-75% valve lift.
	-	Max. Flow	:	90% valve lift.
	-	Min. Flow	:	>10% valve lift.

Valve with Equipercentage Characteristic	-	Normal Flow (Design Point)	:	75-85% valve lift.
	-	Max. Flow	:	90% valve lift.
	-	Min. Flow	:	>10% valve lift.

ON/OFF Quick open Characteristic	-	1.2 times the CV calculated on the basis of maximum flow condition.
----------------------------------	---	---

3.1.9 Calculation for valve sizing, velocity and noise shall be subject to purchaser's approval during contract stage. However, responsibility of proper selection and design for the duties specified lies with the vendor. Any modifications required to be done on the valves or actuators & accessories to achieve satisfactory performance of the control system shall be done without any commercial & delivery implication.

3.1.10 The valve outlet velocities shall be limited to the following values, unless otherwise specified in the Data sheet-A.

- | | | |
|-------------------|----|-----------------|
| i) Liquid service | <= | 8 Meters/Sec. |
| ii) Steam service | <= | 150 Meters/Sec. |

3.1.11 For cavitation service, the trim design shall be of multistage pressure drop type, so as to avoid cavitation altogether, instead of keeping cavitation away from valve parts

3.1.12 The equivalent weighted sound level measured at 1.5 metre above floor level in elevation and 1 metre horizontally from the control valve expressed in decibels to a reference of 0.0002 microbar shall not exceed 85 dBA (without pipe insulation). The offer shall include noise prediction calculations for each valve.



**TECHNICAL SPECIFICATION FOR
AUXILIARY STEAM PRESSURE REDUCING &
DESUPERHEATING STATION**

SPEC. NO.: PE-TS-426-142-N101

SECTION II

REV. NO. 00

DATE 13.01.20

3.1.13 In case of predicted noise level above 85 dBA, same shall be brought down to acceptable noise level i.e. below 85dBA through Source treatment (proper valve trim & valve body selection). Path treatment (LNP/ Diffuser/ Cartridge/ Silencer etc.), if any shall be subject to Customer's/Owner's approval.

3.1.14 In case of wrong selection/mal operation of valve and for associated actuator during guarantee period, the vendor shall replace the valve suitably with a modified/new valve of design as approved by purchaser and all the expenses for replacement, rectification/modification including transportation both ways will be at vendor's expenses.

3.2 **ACTUATORS-** The control valves shall be operated with pneumatic actuator

3.2.1 **Pneumatic Actuator**

The actuator shall be designed for a thrust of 120% of valve's shut-off pressure at an air line supply pressure of 5-8 Kg/Sq. cm.

The pneumatic actuators shall be employed for modulating or open/close duty, as specified in Data Sheet-A. The bidder shall be responsible for proper selection and sizing of valve actuators in accordance with the pressure drops, shut off pressure and valve travel.

The pneumatic spring opposed diaphragm actuator or piston actuator as the case may be for modulating duty shall be capable of positioning the associated valve at desired opening for all the operating conditions specified.

3.2.2 The pneumatic actuator for open/close duty shall be suitable for fast opening/closing of the associated valve.

3.2.3 The actuator design shall allow valve assembly to be mounted at 45° inclination on either side in the vertical plane.

3.2.4 The actuators shall be suitably sized to ensure that the associated valve travel time from full open to full closed position and vice versa is less than 10 seconds or as specified in the datasheet under the most stringent service conditions.

3.3 **Accessories for Control valve with Pneumatic Actuator**

The bidder shall offer all the accessories as specified in the Data Sheet - A for the Pneumatic Actuators under modulating or OPEN/CLOSE duty. The accessories specified shall be supplied duly mounted on the valve actuator and piped with PVC covered copper/ SS tube and flare less brass/ SS fittings etc. as per the hook up diagram (Refer drawing no. PES-145-06B).

3.3.1 **Handwheel**

Handwheel shall have OPEN & CLOSE direction marking and clockwise rotation as viewed from front shall close the valve. The handwheel shall have a circular stainless steel plate with Tag number and service.

3.3.2 **Local Position Indicator**



**TECHNICAL SPECIFICATION FOR
AUXILIARY STEAM PRESSURE REDUCING &
DESUPERHEATING STATION**

SPEC. NO.: PE-TS-426-142-N101

SECTION II

REV. NO. 00

DATE 13.01.20

Each actuator shall be provided with a mechanical pointer attached to stem, moving over a graduated scale with markings, for OPEN, 25%, 50%, 75%, CLOSE positions.

3.3.3 Position Transmitter

The position transmitter shall be integral part of the smart positioner.

3.3.4 Air Filter Regulator

Instrument quality air at suitable pressure of 5 Kg/Cm²(g) to 8 Kg/Cm²(g) shall be supplied to each valve through air filter regulator. The filter regulator shall include an inbuilt blow-down valve (auto drain feature), 5 micron size filter. The bowl material for the AFR shall be sintered bronze. The Air filter regulator shall be selected to meet the requirements of positioner/actuator, E/P convertor and air-lock. The flow capacity of the Air filter regulator shall be variable with a knob. Output gauge shall be provided wherever pneumatic positioner is not specified for the valve.

3.3.5 Air Lock Relay

Air lock relay shall retain the valve position stayput, in case of air supply failure and shall reset automatically on resumption of air supply. Air lock shall have a threaded plug for evacuating diaphragm air if required for local manual operation.

3.3.6 Solenoid Valves

Solenoid valves are meant for interlock & protection purposes overriding the controller signal, and/or to result stayput action on controller signal failure. The Solenoid valve shall be 3-way Universal type and the valve internals and valve body shall be of stainless steel. The coil shall have class-H insulation and rated for continuous AC/DC duty as specified in Data sheet-A. The enclosure shall be to IP-65. Cable gland shall be provided for cable entry. The solenoid shall in general conform to IS-8935. The solenoid shall be provided with manual overriding facility. The solenoid shall be suitable for 24V DC supply, unless specified otherwise in Data Sheet-A.

3.3.7 Limit Switch Assembly

Limit switch assembly are required as specified in the data sheet-A. Each limit switch shall have 2NO+2NC contacts with contact rating of 5A at 240V AC/0.2A at 220V DC unless otherwise specified. The switch enclosure shall conform to IP-65. Each limit switch shall be supplied with cable glands.

3.3.8 I/P Converter

I/P Converter shall be integral part of the smart positioner.



**TECHNICAL SPECIFICATION FOR
AUXILIARY STEAM PRESSURE REDUCING &
DESUPERHEATING STATION**

SPEC. NO.: PE-TS-426-142-N101

SECTION II

REV. NO. 00

DATE 13.01.20

3.3.9 Smart positioner

Microprocessor based Electronic (Smart)Positioner

1	Electrical	a) Input Demand Signal	4-20 mA
		b) Power Supply	Loop Powered from the output card of Control System (12-30 V DC)
		c) HART Protocol	Compatibility for Remote Calibration & Diagnostics (Superimposed HART signal on input Signal (4-20 mA))
		d. Valve position sensing	Position sensing, 4-20 mA output signal to be provided for control system.
2	Environment	a) Operating temp.	(-)30 To 80 Deg. C
		b) Humidity	0-95 %
		c) Protection class	IP-65 Minimum
3	Software for Configuration and Diagnostics	Software	Windows based software. Software shall meet the requirements for Configuration, Diagnostics, Calibration and Testing of the actuator. It shall be easily upgradable with some hardware and compatible with any HART management system/AMS. Valve positioning timing, actuator leakage, and valve wear and tear, fault alarm to be offered as a minimum.
		Diagnostic/Test features	Advanced diagnostic features like Stroke counter or Travel counter, Leakage in actuators, Valve Signature analysis, Step Response test, Valve friction /Jamming detection etc. to be provided.
4	Test reports/ Certificates	Factory Valve Signature Tests Reports (Pressure versus Valve travel and Travel versus I/P signal) are to be provided.	
		Test certificates as per manufacture standard/Relevant standard are to be submitted.	
5	Configuration/ Calibration	Remote & Local Calibration, Auto & Manual Calibration shall be possible.	
6	Operating Range	Full range/ Split range.	
7	Modes	Valve Action	Direct / Reverse Valve Action
		Flow Characterization	Possible to fit Valve Characteristic Curves- Linear , Equal percentage etc.
8	Fail Safe/Fail Freeze	Fail Safe/Fail Freeze feature is to be provided as per datasheet. (In case the fail freeze feature is not intrinsic to the positioner, Bidder shall achieve the same externally through solenoid valve Connected in the pneumatic circuit).	



**TECHNICAL SPECIFICATION FOR
AUXILIARY STEAM PRESSURE REDUCING &
DESUPERHEATING STATION**

SPEC. NO.: PE-TS-426-142-N101

SECTION II

REV. NO. 00

DATE 13.01.20

9	Pneumatic	Air capacity	Sufficient to handle the valves & actuators selected/ Boosters to be supplied, if required.
		Air pressure	To suit the air supply pressure/quality available.
		Process connection	1/4" NPT
10	Performance	characteristic deviation	<=0.5 % of span. (<0.75%)
		ambient temp effect	<=0.01 %/ deg c or better.
		dead band	adjustable to 0.1to 10%
		scan time	10ms
		resolution	<=0.05%
		sensitivity/linearity	0.3-0.4% of FS
		repeatability	0.32% of FS
		auto tune	yes
11	EMC & CE compliance	Required to International Standard like EN/IEC.	EN50081-2 & EN50082 or equivalent.
12	Accessories	In-built Operator Panel	Display with push buttons for configuration and display on the positioner itself (Password protected/Hardware lock).
		Pressure Gauge Block & Position Indicators.	For supply & output pressures, Air Filter Regulator, integral type position transmitter, in built mechanical position indicator and other accessories shall be provided on as required basis for making system complete.
		Electrical Cable Entry	1/2" NPT, side or bottom entry to avoid water ingress.
		Valves Mounting Assembly	For Sliding Stem/Rotary/Single acting/Double acting actuators on as required basis.

3.3.10 Junction Box

Integral junction box with all electrical accessories conduited up to JB shall be supplied. The junction box shall have two (2) cable glands for outgoing cables. Junction box shall have enclosure class of IP-65.

3.4 **Painting** of the control valve assembly shall be as per the Painting Specification attached elsewhere in this technical specification. In the absence of specification for painting, vendor to submit their standard painting procedure for painting for BHEL's approval. Epoxy based paint (corrosion-resistant) to be provided for control valves for coastal environment.

3.5 **Sub-vendors** shall be subject to BHEL/ Customer/Customer's Consultant approval in the event of order.

4.0 TESTING AND INSPECTION



**TECHNICAL SPECIFICATION FOR
AUXILIARY STEAM PRESSURE REDUCING &
DESUPERHEATING STATION**

SPEC. NO.: PE-TS-426-142-N101

SECTION II

REV. NO. 00

DATE 13.01.20

- 4.1 The testing and inspection of the equipment/items shall be in line with the approved QAP
- 4.2 The cost of all tests as per the approved QAP will be deemed to have been included in the bid.
- 4.3 In case, the bidder is supplying the valve from outside India, the third party inspection shall be arranged and considered by the bidder in their offer.

5.0 SPARES AND CONSUMABLES

5.1 Start-up/Commissioning Spares

The bidder shall supply all the start-up/commissioning spares as per the BOQ given in the technical specification.

S.No.	ITEM DESCRIPTION	QUANTITY REQUIRED (per unit)
1	Gaskets	One (1) set with each control valve Tag
2	Gland Packings	One (1) set with each control valve Tag
3	SS Tubing (as applicable)	12 Meters of 1/4 " SS Tubing, with 1 set of Fittings for each CV

5.2 Mandatory Spares

The bidder shall supply all the mandatory spares as per the BOQ given in the technical specification.

6.0 DRAWINGS AND DOCUMENTS

6.1 The bidder shall furnish the following documents (4sets) along with the bid

- Compliance certificate as enclosed in Section II.
- Schedule of deviations if any.
- Sizing Calculations.
- General Assembly (GA) drawings indicating all important details for layout.
- Quality Plan duly signed & stamped.
- Relevant Catalogs with detailed technical information.
- Un-price schedule of prices & unit prices as per NIT.

6.2 The successful bidder shall furnish the following documents to BHEL during the contract stage viz. after the award of contract:



**TECHNICAL SPECIFICATION FOR
AUXILIARY STEAM PRESSURE REDUCING &
DESUPERHEATING STATION**

SPEC. NO.: PE-TS-426-142-N101

SECTION II

REV. NO. 00

DATE 13.01.20

6.2.1 2 sets of the following CONTROL VALVE DOCUMENTS for approval + 1 sets of CD/soft copy:

- All Sizing Calculations (CV, Noise Level, Valve Outlet Velocity, Actuator sizing etc.)
- General Assembly (GA) drawings indicating all important details (edge preparation details, dimensions, weight etc) for layout.
- Data sheet-B completely filled-up.
- Hook-up diagram of Control Valve with Actuator & Accessories.
- Quality Plan duly signed & stamped.
- Relevant Catalogs with detailed technical information.

6.3 Final documentation:

Final Documents / drawings to be furnished by the successful bidder shall be as follows:
12 sets with 5 CD-ROMS/Soft Copy of:-

- Category I & IV approved CONTROL VALVE DOCUMENTS
- Test certificates
- Operation & maintenance manuals for Control Valve, Actuator and all accessories

7.0 MARKING AND PACKING

7.1 Marking

A stainless steel metal nameplate should be permanently fixed on each equipment giving its tag number and technical specifications. The Following Details are to be marked on the Packing Cases

- ✓ *Address of consignee*
- ✓ *Purchase order no.*
- ✓ *Description of items or title of packing list*
- ✓ *Weight*
- ✓ *Dimension of the Box*
- ✓ *Marking showing upright position*
- ✓ *Marking showing sling position*
- ✓ *Marking showing umbrella (i.e. for machines/components to be stored under covered storage)*



7.2 Packing



**TECHNICAL SPECIFICATION FOR
AUXILIARY STEAM PRESSURE REDUCING &
DESUPERHEATING STATION**

SPEC. NO.: PE-TS-426-142-N101

SECTION II

REV. NO. 00

DATE 13.01.20

All equipment / materials shall be suitably packed and protected for the entire period of dispatch, storage and erection against impact, abrasion, corrosion, incidental damage due to vermin, sunlight, high temperature, rain, moisture, humidity, dust, sea water spray (where applicable) as well as rough handling and delays in transit and storage in open. Guidelines for packing are as follows:

- ✓ *After inspection of control valves assembly, smart Positioner along with Pressure Gauge shall be disassembled & packed separately.*
- ✓ *Threaded connection of Smart Positioner & Pressure Gauge shall be shipped with the end caps fitted to avoid any damage.*
- ✓ *Instructions with sketch for mounting the Smart Positioner & Pressure Gauge shall be sent along with the aforesaid accessories.*
- ✓ *Packing of the control valves and Smart Positioner along with Pressure Gauge shall be done in separate wooden boxes/cases in order to avoid damage during transit and also during storage at site in tropical climatic conditions for a period of 18-24 months.*
- ✓ *All valves & smart positioner along with pressure gauges shall be packed properly with quality wooden planks with proper wooden frame support. Moreover the valves are internally covered with polythene sheets to protect from the water and moisture entry.*
- ✓ *Stronger shock absorbing cover material like expanded Polyurethane which can take any direct impact on it shall be used for packing.*
- ✓ *Proper reaper support to be provided in the packing and Valve assembly to be aligned properly to avoid the damage of accessories during transit due to vibration effect.*
- ✓ *Marking for Fragile & Condensing environment shall be done on the packing box.*



Technical specification for
Control Valves with Accessories
(Pneumatically Operated)

SPECIFICATION NO. **PE-TS 426 145-1801**

DOCUMENT NO.

VOLUME **II-B**SECTION **D**

ISSUE NO. 2

REV. NO. 00

DATE :

SECTION-D

SPECIFICATION FOR SMART POSITIONER (PES-145-06A)

	SPECIFICATIONS FOR MICROPROCESSOR BASED ELECTRONIC POSITIONER (SMART)	SPECIFICATION NO.: PE-TS- 426 -145-1801
		DOCUMENT NO.: PES-145-06A
		VOLUME. II B
		SECTION D
		ISSUE NO. 2 . REV.00

1.0 Electrical

Input Signal	4-20mA
Power Supply	Loop Powered from the output card of Control System (12-30 V DC)
Hart Protocol	Compatibility For Remote Calibration & Diagnostic (Super-Imposed HART Signal On Input Signal (4-20mA)
Valve Position Feedback (4-20mA)	Position Sensing 4-20mA O/P Signal For Control System To Be Provided. If non contact type of Position feedback signal is required, Position transmitter to be separately provided.

2.0 Environment

Operating Temperature	(-) 30 To 80 Deg.C
Humidity	0-95%
Protection Class	IP-65 (Minimum)

3.0 Software For Configuration & Diagnostic

Software	Windows Based Software, Software Shall Meet The Requirement For Configuration, Diagnostics, Calibration And Testing Of the Actuator. Valve positioning timing, actuator leakage, and Valve Wear & tear, fault alarm to be offered as a minimum. Easily up gradable with same hardware and compatible with any HART management systems / AMS.
Diagnostic/Test Features (Optional)	Advanced Diagnostic Features Like Stroke On Line Partial Closure Test, Valve Signature Analysis (Online graphical representation), Step Response Test, Valve Friction/Jamming Detection Etc To Be Provided.

	SPECIFICATIONS FOR MICROPROCESSOR BASED ELECTRONIC POSITIONER (SMART)	SPECIFICATION NO.: PE-TS 426 -145-1801
		DOCUMENT NO.: PES-145-06A
		SECTION D
		ISSUE NO. 2 . REV.00

Factory Valve Signature Tests Reports (Pr Vs Valve Travel And Travel Vs I/P Signal) Are To Be Provided.

Hardware PC For Configuration/Software (OPTIONAL)

Test Certificates Test Certificates As Per Manufacture Standard/Relevant Standard Are To Be Submitted.

Configuration / Remote Calibration, Auto & Manual Calibration Shall Be Possible.

4.0 Modes

Valve Action Direct & Reverse, Valve Action.
(Same positioner for Single Acting or Double Acting And no separate relays required for changing from Single acting to double).

Flow Characterization Possible to fit valve characteristic curve linear & Equal percentage

Fail Safe/Fail Freeze (Optional) Fail Safe/Fail Freeze feature is to be provided.

5.0 Performance

Characteristic Deviation $\leq 0.75\%$ of span

Ambient temp effect $\leq 0.01\%$ /Deg C or better.

Dead Band Adjustable 0.1 to 10%.

Scan Time 10ms

Resolution $\leq 0.05\%$

Sensitivity/Linearity 0.3-0.4% of FS

Repeatability 0.32% of FS

Auto-Tune Yes



Technical specification for
Control Valves with Accessories
(Pneumatically Operated)

SPECIFICATION NO. **PE-TS 426 .145-1801**

DOCUMENT NO.

VOLUME **II-B**SECTION **D**

ISSUE NO. 2

REV. NO. 00

DATE :

SECTION-D

HOOK-UP DIAGRAM (PES-145-06B)

STANDARD CONTROL VALVE HOOK-UP DIAGRAM (WITH SMART POSITIONER)

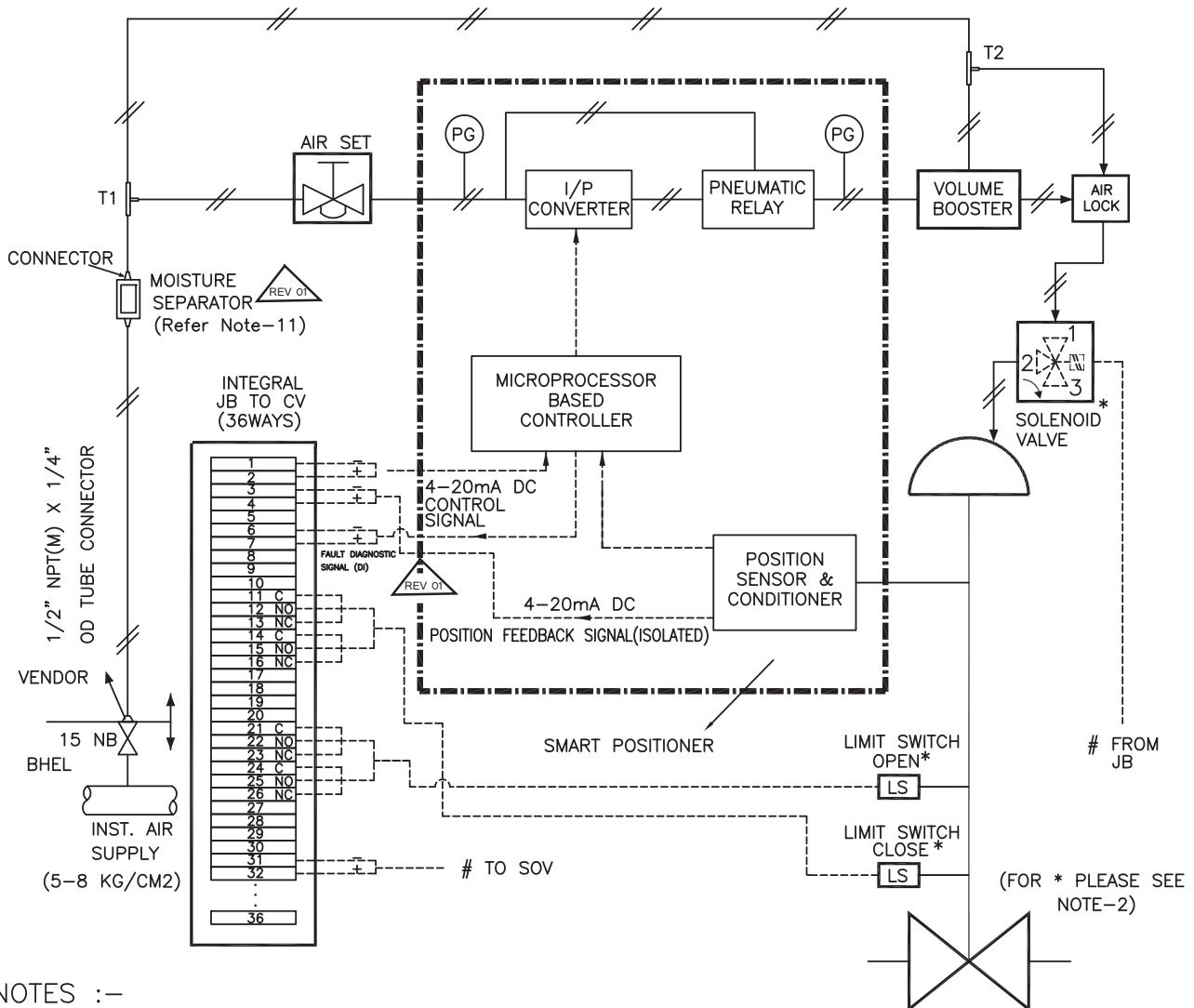

NOTES :-

1. POSITION OF EACH VALVE ON SUPPLY AIR FAILURE / ELECTRICAL SIGNAL FAILURE SHALL BE AS PER SPECIFICATION / DATA SHEET.
2. SOLENOID VALVE & LIMIT SWITCHES WILL BE PROVIDED ONLY FOR CONTROL VALVES IF INDICATED IN RESPECTIVE DATA SHEETS.
3. SOLENOID VALVES PORTS CONDITION:
PORT 1 AND 2 SHALL BE CONNECTED UNDER DE-ENERGISED CONDITION.
PORT 2 AND 3 SHALL BE CONNECTED UNDER ENERGISED CONDITION.
4. PRESSURE GAUGES REQUIRED FOR AIR SUPPLY & OUTPUT(S).
5. MOUNTING ACCESSORIES AS REQUIRED.
6. POSITION FEEDBACK SIGNAL SHALL BE 2 WIRE 4-20ma ISOLATED SIGNAL.
7. JB TERMINALS SHALL BE CAGE CLAMP TYPE SUITABLE FOR 2.5 SQ. MM COPPER WIRE. EXTERNAL CONNECTION, OF PLUG IN TYPE OR THROUGH CABLE GLAND, SHALL BE AS PER DATA SHEET
8. ALL APPLICABLE ACCESSORIES SHALL BE PROVIDED AS INDICATED IN THE INDIVIDUAL CONTROL VALVE DATA SHEET / ACCESSORIES DATA SHEET.
9. 12 METERS 1/4" SS 316 TUBING (AS PER ACCESSORIES DATA SHEET) & 1 SET OF FITTINGS TO BE SUPPLIED FOR EACH CONTROL VALVE FOR CONNECTION TO ISO VLV AT INST AIR HEADER ON ONE END AND TO AIR LOCK RELAY/AIR FILTER REGULATOR ON THE OTHER END. ALL THE BRASS / SS FITTINGS SHALL BE DOUBLE COMPRESSION TYPE.
10. VOLUME BOOSTER (ALONG WITH TEE-T2 AND RELATED TUBING & CONNECTORS) SHALL BE PROVIDED IF REQUIRED. AIR CONNECTION TO VOLUME BOOSTER FROM TEE-T2 SHALL BE PROVIDED.
11. SEPARATE MOISTURE SEPARATOR TO BE PROVIDED WITH EACH CONTROL VALVE. NECESSARY HARDWARE & SUITABLE CONNECTOR FOR MOUNTING THE MOISTURE SEPARATOR TO BE PROVIDED BY THE BIDDER.
12. ALL REQUIRED ACCESSORIES I.E. SOLENOID OR ANY OTHER HARDWARE REQUIRED TO ACHIEVE STAYPUT AT CONTROLLER SIGNAL FAILURE SHALL BE PROVIDED.
13. DI FOR FAULT SIGNAL OF THE SMART POSITIONER SHALL BE PROVIDED.

	DOCUMENT NO : PE-TS-426-145-I104	DRG. No.	PES-145-06B		
	TITLE:- CONTROL VALVE HOOK-UP DIAGRAM	REV. No.	01	DATE	20.11.2017
	SHEET	49	OF	55	

STANDARD CONTROL VALVE HOOK-UP DIAGRAM (FOR ON / OFF TYPE)

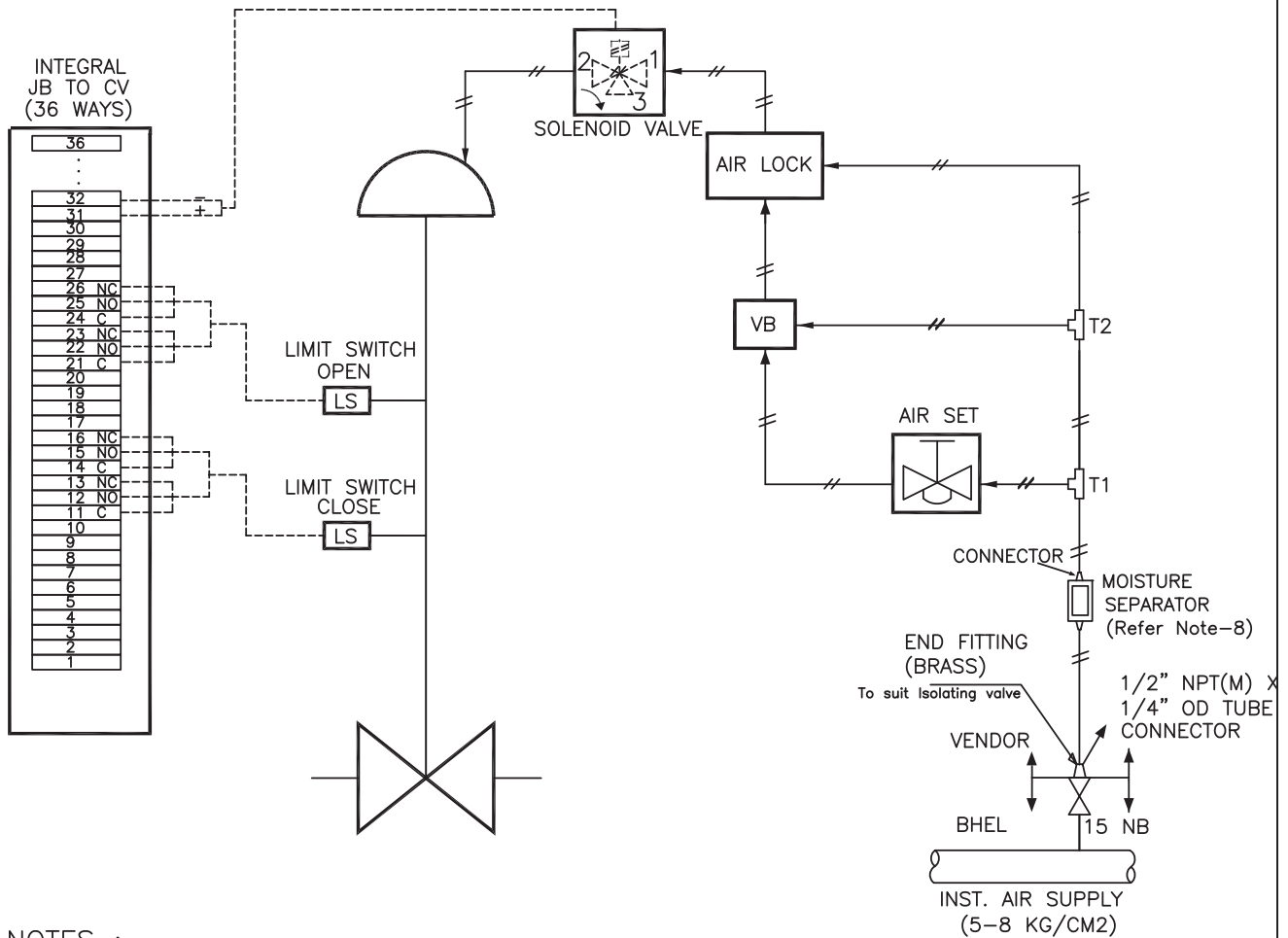

NOTES :-

1. POSITION OF EACH VALVE ON SUPPLY AIR FAILURE / ELECTRIC SIGNAL FAILURE SHALL BE AS PER SPECIFICATION / DATA SHEET.
2. SOLENOID VALVES PORTS CONDITION:
PORT 1 AND 2 SHALL BE CONNECTED UNDER DE-ENERGISED CONDITION.
PORT 2 AND 3 SHALL BE CONNECTED UNDER ENERGISED CONDITION.
3. MOUNTING ACCESSORIES AS REQUIRED.
4. JB TERMINALS SHALL BE CAGE CLAMP TYPE SUITABLE FOR 2.5 SQ. MM COPPER WIRE. EXTERNAL CONNECTION, OF PLUG IN TYPE OR THROUGH CABLE GLAND, SHALL BE AS PER DATA SHEET.
5. ALL APPLICABLE ACCESSORIES SHALL BE PROVIDED AS INDICATED IN THE INDIVIDUAL CONTROL VALVE DATA SHEET / ACCESSORIES DATA SHEET.
6. 12 METERS 1/4" SS 316 TUBING (AS PER ACCESSORIES DATA SHEET) & 1 SET OF FITTINGS TO BE SUPPLIED FOR EACH CONTROL VALVE FOR CONNECTION TO ISO VLV AT INST AIR HEADER ON ONE END AND TO AIR LOCK RELAY/AIR FILTER REGULATOR ON THE OTHER END. ALL THE BRASS / SS FITTINGS SHALL BE DOUBLE COMPRESSION TYPE.
7. VOLUME BOOSTER (ALONG WITH TEE-T2 AND RELATED TUBING & CONNECTORS) SHALL BE PROVIDED IF REQUIRED. AIR CONNECTION TO VOLUME BOOSTER FROM TEE-T2 SHALL BE PROVIDED.
8. SEPARATE MOISTURE SEPARATOR TO BE PROVIDED WITH EACH CONTROL VALVE. NECESSARY HARDWARE & SUITABLE CONNECTOR FOR MOUNTING THE MOISTURE SEPARATOR TO BE PROVIDED BY THE BIDDER.
9. ALL REQUIRED ACCESSORIES i.e. SOLENOID OR ANY OTHER HARDWARE REQUIRED TO ACHIEVE STAYPUT AT CONTROLLER SIGNAL FAILURE SHALL BE PROVIDED.



DOCUMENT NO : PE-TS-426-145-I104

DRG.
No.

PES-145-06B

TITLE:-

CONTROL VALVE HOOK-UP DIAGRAM

REV.
No.

01

DATE 20.11.2017

SHEET

50

OF

55

STANDARD CONTROL VALVE HOOK-UP DIAGRAM (DOUBLE ACTING PISTON ACTUATOR WITH SMART POSITIONER)

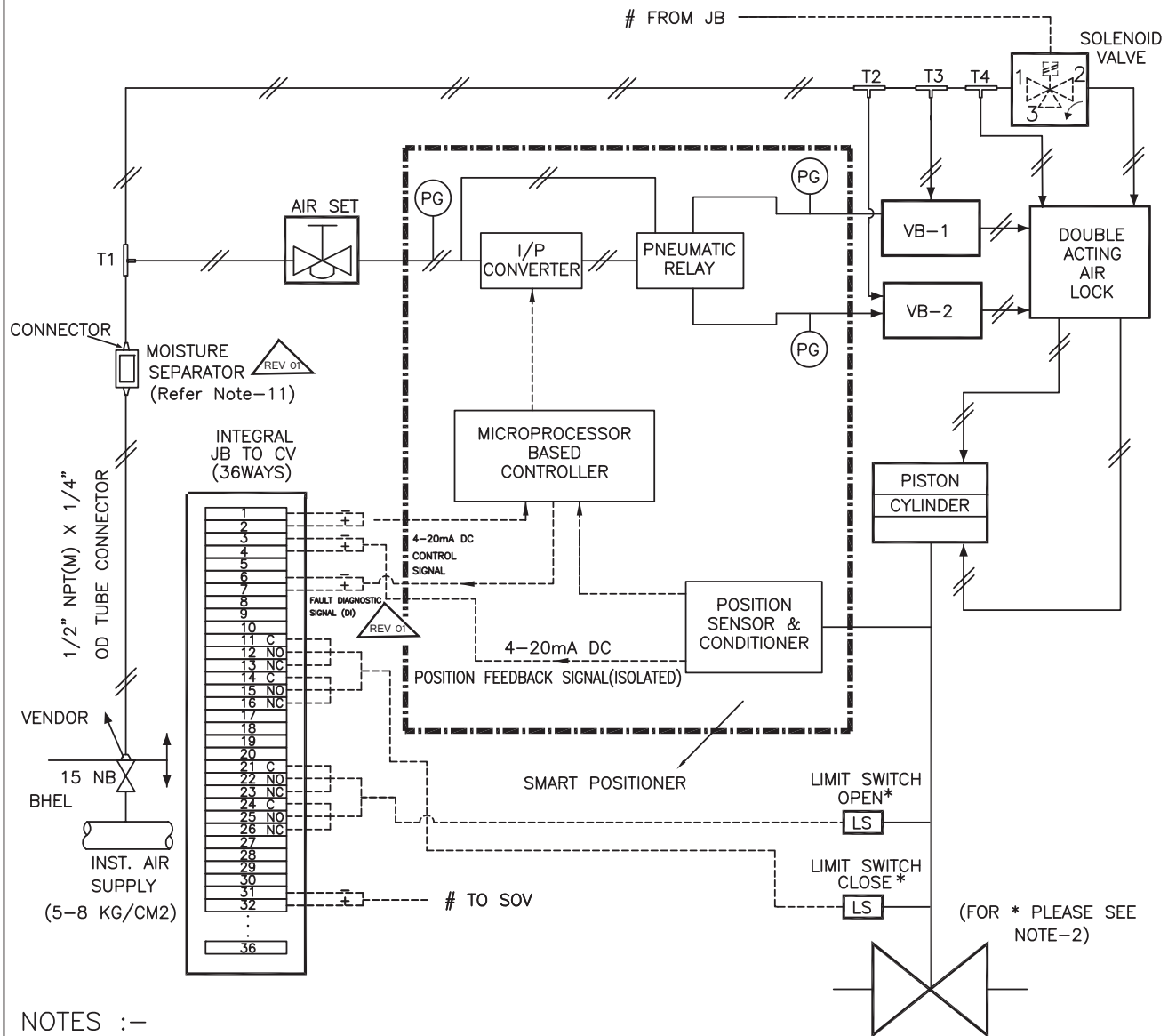

NOTES :-

1. POSITION OF EACH VALVE ON SUPPLY AIR FAILURE / ELECTRICAL SIGNAL FAILURE SHALL BE AS PER SPECIFICATION / DATA SHEET. AIR LOCK SHALL BE PROVIDED ACCORDINGLY.
2. SOLENOID VALVE & LIMIT SWITCHES WILL BE PROVIDED ONLY FOR CONTROL VALVES IF INDICATED IN RESPECTIVE DATA SHEETS.
3. SOLENOID VALVES PORTS CONDITION:
PORT 1 AND 2 SHALL BE CONNECTED UNDER DE-ENERGISED CONDITION.
PORT 2 AND 3 SHALL BE CONNECTED UNDER ENERGISED CONDITION.
4. PRESSURE GAUGES REQUIRED FOR AIR SUPPLY & OUTPUT(S).
5. MOUNTING ACCESSORIES AS REQUIRED.
6. POSITION FEEDBACK SIGNAL SHALL BE 2 WIRE 4-20mA ISOLATED SIGNAL.
7. JB TERMINALS SHALL BE CAGE CLAMP TYPE SUITABLE FOR 2.5 SQ. MM COPPER WIRE. EXTERNAL CONNECTION, OF PLUG IN TYPE OR THROUGH CABLE GLAND, SHALL BE AS PER DATA SHEET
8. ALL APPLICABLE ACCESSORIES SHALL BE PROVIDED AS INDICATED IN THE INDIVIDUAL CONTROL VALVE DATA SHEET / ACCESSORIES DATA SHEET.
9. 1/2 METERS 1/4" SS 316 TUBING (AS PER ACCESSORIES DATA SHEET) & 1 SET OF FITTINGS TO BE SUPPLIED FOR EACH CONTROL VALVE FOR CONNECTION TO ISO VLV AT INST AIR HEADER ON ONE END AND TO AIR LOCK RELAY/AIR FILTER REGULATOR ON THE OTHER END. ALL THE BRASS / SS FITTINGS SHALL BE DOUBLE COMPRESSION TYPE.
10. VOLUME BOOSTER (ALONG WITH TEE-T2 AND RELATED TUBING & CONNECTORS) SHALL BE PROVIDED IF REQUIRED. AIR CONNECTION TO VOLUME BOOSTER FROM TEE-T2 & TEE-T3 SHALL BE PROVIDED.
11. SEPARATE MOISTURE SEPARATOR TO BE PROVIDED WITH EACH CONTROL VALVE. NECESSARY HARDWARE & SUITABLE CONNECTOR FOR MOUNTING THE MOISTURE SEPARATOR TO BE PROVIDED BY THE BIDDER.
12. ALL REQUIRED ACCESSORIES i.e. SOLENOID OR ANY OTHER HARDWARE REQUIRED TO ACHIEVE STAYPUT AT CONTROLLER SIGNAL FAILURE SHALL BE PROVIDED.
13. DI FOR FAULT SIGNAL OF THE SMART POSITIONER SHALL BE PROVIDED.

	DOCUMENT NO : PE-TS-426-145-I104	DRG. No.	PES-145-06B		
	TITLE:- CONTROL VALVE HOOK-UP DIAGRAM	REV. No.	01	DATE	20.11.2017
	SHEET	51	OF	55	



MANUFACTURER/BIDDER/
SUPPLIER NAME & ADDRESS

STANDARD QUALITY PLAN

CUSTOMER :--	SPEC. NO. :--	DATE: --
PROJECT: --	QP NO.: PE-QP-999-145-1.006	DATE: 10.01.2020
ITEM: CONTROL VALVE	PO NO.: --	DATE: --
SYSTEM: C&I	SECTION: C	SHEET 2 OF 9

SL NO.	COMPONENT & OPERATIONS	CHARACTERISTIC CHECKED	CATEGORY	TYPE OF CHECK	QUANTUM OF CHECK	REFERENCE DOCUMENT	ACCEPTANCE NORMS	FORMAT OF RECORD	AGENCY	REMARKS
1	2	3	4	5	6	7	8	9	**	
					M			D	M	C
									N	

1.2	Diaphragm	1.Surface Quality	MA	Visual	100%	Mfr. standard	Mfr. standard	Inspection Report	√	P/W	V
		2.Hardness	MA	Measurement	100%	Mfr. standard	Mfr. standard	Inspection Report	√	P/W	V
		3.Endurance/ Life cycle	MA	Cyclic Test 10,000 cycles	One/ type	10,000 cycles/Mfr. standard	No damage	Test Certificate	√	P/W	V
1.3	Spring	1. Composition	MA	Chemical-Analysis	One Sample/ Heat	Mfr. standard	Mfr. standard	Test Certificate	√	P/W	V
		2. Mech. Properties	MA	Mech. Test	One Sample/ Heat	Mfr. standard	Mfr. standard	Test Certificate	√	P/W	V
		3. Performance	MA	1.Stiffness Ratio	100%	Mfr. standard	Mfr. standard	Inspection Report	√	P/W	V
				2.Scragging	100%	Mfr. standard	Mfr. standard	Inspection Report	√	P/W	V
				3.Cyclic Test (Endurance)	One/ type	10,000 cycles	Mfr. standard	Test Certificate	√	P	W
				4. Dimension (Measurement)	One sample/ Lot	Mfr. standard	Mfr. standard	Inspection Report	√	P/ W	V

BHEL				BIDDER/ SUPPLIER				FOR CUSTOMER REVIEW & APPROVAL			
ENGINEERING		QUALITY		SIGN & DATE		SIGN & DATE		SIGN & DATE		SIGN & DATE	
Prepared by:	<i>[Signature]</i>	Name	CHETAN MALIK	Sign & Date	<i>[Signature]</i>	Name	KUNDAN PRASAD	Sign & Date		Name	
Reviewed by:	<i>[Signature]</i>	Checked by:	R.K. RAINA	Sign & Date	<i>[Signature]</i>	Reviewed by:	R.K. JAISWAL	Sign & Date		Approved by:	
		Reviewed by:		Sign & Date		Approved by:		Sign & Date		Seal	



MANUFACTURER/BIDDER/
SUPPLIER NAME & ADDRESS

STANDARD QUALITY PLAN

CUSTOMER :--
PROJECT :--
ITEM: CONTROL VALVE

SPEC. NO : --
QP NO.: PE-QP-999-145-I 006
PO NO.: --
SECTION: C

DATE: --
DATE: 10.01.2020
DATE: --
SHEET 3 OF 9

SL NO.	COMPONENT & OPERATIONS	CHARACTERISTIC CHECKED	CATEGORY	TYPE OF CHECK	QUANTUM OF CHECK	REFERENCE DOCUMENT	ACCEPTANCE NORMS	FORMAT OF RECORD	AGENCY	REMARKS
1	2	3	4	5	6	7	8	9	**	
					M	C/N			M C N	

2.0 IN PROCESS INSPECTION

2.1	After machining, i. Body ii Bonnet iii Plug iv Valve Stem v seat ring/cage	1. Surface flaws	MA	Visual & MT/PT	100% (on accessible surfaces)	ASME B 16.34	ASME B 16.34	Inspection Report	PI W	Butt weld ends shall be included.
		2. Dimensional checks	MA	Measurement	100%	Mfr. standard		Inspection Report	PI W	
		3. Hard Facing (wherever applicable)	MA	Hardness Measurement	One sample/Lot	Mfr. standard		Inspection Report	PI W	

FINAL TESTING/INSPECTION

3.0 TESTS ON COMPLETED VALVE										
3.1	Actuator Chamber	Leakage & Strength	MA	Pneumatic Test	100%	Mfr. standard	No Leakage	Test Certificate	PI W	
3.2	Body	Leakage & Strength(Body Mount Leakage)	MA	Hydro Test	100%	ISA-S-75.19/ ASMEB16.34	No Leakage	Test Certificate	PI W	
3.3	Seat Leakage	Seat Leakage	MA	Pneumatic Test	100%	FCI-70.2	FCI-70.2	Test Certificate	PI W	
4.0	OPERATION TEST ON	1. Valve Travel	MA	Measurement	100%	Mfr. procedure	Approved drg/data	Inspection Report	PI W	

ENGINEERING		QUALITY	
Sign & Date	Name	Sign & Date	Name
<i>[Signature]</i> 10/1/2020	CHETAN MALIK	<i>[Signature]</i> 10/1/2020	KUNDAN PRASAD
Prepared by:	Checked by:	Reviewed by:	Reviewed by:
<i>[Signature]</i> 10/1/2020	R.K. RAINA	<i>[Signature]</i> 10/1/2020	R.K. JAISWAL

BIDDER/ SUPPLIER	
Sign & Date	Seal

FOR CUSTOMER REVIEW & APPROVAL	
Doc No:	Seal
Reviewed by:	Sign & Date
Approved by:	Name

		MANUFACTURER/BIDDER/ SUPPLIER NAME & ADDRESS		STANDARD QUALITY PLAN				SPEC. NO. :-		DATE: --	
CUSTOMER :-		PROJECT :-		ITEM: CONTROL VALVE		SYSTEM: C&I		SECTION: C		SHEET 4 OF 9	
SL NO.		CHARACTERISTIC CHECKED		CATEGORY		TYPE OF CHECK		QUANTUM OF CHECK		REFERENCE DOCUMENT	
1		3		4		5		6		7	
2		3		4		5		6		7	
3		4		5		6		7		8	
4		5		6		7		8		9	
5		6		7		8		9		10	
6		7		8		9		10		11	
7		8		9		10		11		12	
8		9		10		11		12		13	
9		10		11		12		13		14	
10		11		12		13		14		15	
11		12		13		14		15		16	
12		13		14		15		16		17	
13		14		15		16		17		18	
14		15		16		17		18		19	
15		16		17		18		19		20	
16		17		18		19		20		21	
17		18		19		20		21		22	
18		19		20		21		22		23	
19		20		21		22		23		24	
20		21		22		23		24		25	
21		22		23		24		25		26	
22		23		24		25		26		27	
23		24		25		26		27		28	
24		25		26		27		28		29	
25		26		27		28		29		30	
26		27		28		29		30		31	
27		28		29		30		31		32	
28		29		30		31		32		33	
29		30		31		32		33		34	
30		31		32		33		34		35	
31		32		33		34		35		36	
32		33		34		35		36		37	
33		34		35		36		37		38	
34		35		36		37		38		39	
35		36		37		38		39		40	
36		37		38		39		40		41	
37		38		39		40		41		42	
38		39		40		41		42		43	
39		40		41		42		43		44	
40		41		42		43		44		45	
41		42		43		44		45		46	
42		43		44		45		46		47	
43		44		45		46		47		48	
44		45		46		47		48		49	
45		46		47		48		49		50	
46		47		48		49		50		51	
47		48		49		50		51		52	
48		49		50		51		52		53	
49		50		51		52		53		54	
50		51		52		53		54		55	
51		52		53		54		55		56	
52		53		54		55		56		57	
53		54		55		56		57		58	
54		55		56		57		58		59	
55		56		57		58		59		60	
56		57		58		59		60		61	
57		58		59		60		61		62	
58		59		60		61		62		63	
59		60		61		62		63		64	
60		61		62		63		64		65	
61		62		63		64		65		66	
62		63		64		65		66		67	
63		64		65		66		67		68	
64		65		66		67		68		69	
65		66		67		68		69		70	
66		67		68		69		70		71	
67		68		69		70		71		72	
68		69		70		71		72		73	
69		70		71		72		73		74	
70		71		72		73		74		75	
71		72		73		74		75		76	
72		73		74		75		76		77	
73		74		75		76		77		78	
74		75		76		77		78		79	
75		76		77		78		79		80	
76		77		78		79		80		81	
77		78		79		80		81		82	
78		79		80		81		82		83	
79		80		81		82		83		84	
80		81		82		83		84		85	
81		82		83		84		85		86	
82		83		84		85		86		87	
83		84		85		86		87		88	
84		85		86		87		88		89	
85		86		87		88		89		90	
86		87		88		89		90		91	
87		88		89		90		91		92	
88		89		90		91		92		93	
89		90		91		92		93		94	
90		91		92		93		94		95	
91		92		93		94		95		96	
92		93		94		95		96		97	
93		94		95		96		97		98	
94		95		96		97		98		99	
95		96		97		98		99		100	

SL NO.	CHARACTERISTIC CHECKED	CATEGORY	TYPE OF CHECK	QUANTUM OF CHECK	REFERENCE DOCUMENT	ACCEPTANCE NORMS	FORMAT OF RECORD	AGENCY	REMARKS
1	2. Opening/ Closing Time	MA	Measurement	100%	Mfr. procedure	Approved drg/data sheet	Inspection Report	P/W	
2	3. Linearity/Cam characteristic	MA	Measurement	100%	Mfr. procedure	Approved drg/data sheet	Inspection Report	P/W	
3	4. Repeatability	MA	Measurement	100%	Mfr. procedure	Approved drg/data sheet	Inspection Report	P/W	
4	5. Hysteresis	MA	Measurement	100%	Mfr. procedure	Approved drg/data sheet	Inspection Report	P/W	
5	6. Sensitivity	MA	Measurement	100%	Mfr. procedure	Approved drg/data sheet	Inspection Report	P/W	
6	7. Accuracy(Over rall)	MA	Measurement	100%	Mfr. procedure	Approved drg/data sheet	Inspection Report	P/W	
7	8. Control Valve characteristics / CV Test	MA	Measurement	One per type	Mfr. Procedure	Approved drg/data sheet	Test Certificate	P/W	◆ Size = Body size & size or Body size & CV for non std port. Refer Note 1.
8	9. Operation of	MA	Function	100%	Mfr. Procedure	Approved	Inspection	P/W	On assembled

ENGINEERING		QUALITY	
Sign & Date	Name	Sign & Date	Name
<i>[Signature]</i>	CHETAN MALIK	<i>[Signature]</i>	KUNDAN PRASAD
Prepared by:	Checked by:	Reviewed by:	Reviewed by:
<i>[Signature]</i>	<i>[Signature]</i>	<i>[Signature]</i>	R.K. JAISWAL
10/11/2020	10/11/2020	10/11/2020	10/11/2020

FOR CUSTOMER REVIEW & APPROVAL			
Doc No:	Sign & Date	Name	Seal
Reviewed by:			
Approved by:			



		STANDARD QUALITY PLAN				SPEC. NO. : --		DATE: --		
						CUSTOMER :--		QP NO.: PE-QP-999-145-I 006		DATE: 10.01.2020
MANUFACTURER/BIDDER/ SUPPLIER NAME & ADDRESS		PROJECT :-- ITEM: CONTROL VALVE				PO NO.: --		DATE: --		
						SYSTEM: C&I		SECTION: C		SHEET 5 OF 9
SL NO.	COMPONENT & OPERATIONS	CHARACTERISTIC CHECKED	CATEGORY	TYPE OF CHECK	QUANTUM OF CHECK	REFERENCE DOCUMENT	ACCEPTANCE NORMS	FORMAT OF RECORD	AGENCY	REMARKS
1	2	3	4	5	6	7	8	9	M C N	
		limit switch & solenoids and other accessories			M	C/N		*	D	

										Valve.
		10. Overall dimensions	MI	Visual and dimensional	100%	10%	Approved drg./data sheet	Inspection Report	P/W	
		11. Pre defined valve position in case of air failure	MI	Visual and dimensional	100%	10%	Approved drg. / data sheet	Inspection Report	P/W	
		12. Cleanliness, painting, stamping (for direction of flow), Tag No.	MA	Visual and dimensional, paint thickness	100%	10%	Mfr. Procedure	Test Certificate	P/W	
		13. Surface Quality	MA	Visual	100%	10%	ANSI/ MSS-SP-55	Test Certificate	P/W	

BHEL				BIDDER/SUPPLIER				FOR CUSTOMER REVIEW & APPROVAL					
ENGINEERING		QUALITY		Sign & Date		Sign & Date		Sign & Date		Name		Seal	
Prepared by:	<i>[Signature]</i>	Name	CHETAN MALIK	Checked by:	<i>[Signature]</i>	Name	KUNDAN PRASAD	Reviewed by:	<i>[Signature]</i>	Approved by:	<i>[Signature]</i>		
Reviewed by:	<i>[Signature]</i>	Name	R. K. RAJNA	Reviewed by:	<i>[Signature]</i>	Name	R. K. JAISWAL						





		STANDARD QUALITY PLAN				SPEC. NO. : --		DATE: --			
						CUSTOMER : --		DATE: 10.01.2020			
MANUFACTURER/BIDDER/ SUPPLIER NAME & ADDRESS		PROJECT : --				QP NO.: PE-QP-999-145-1 006		DATE: --			
						PO NO.: --		DATE: --			
ITEM: CONTROL VALVE		SYSTEM: C&I				SECTION: C		SHEET 6 OF 9			
						CATE GORY		TYPE OF CHECK		REFERENCE DOCUMENT	
COMPONENT & OPERATIONS		CHARACTERISTIC CHECKED		QUANTUM OF CHECK		ACCEPTANCE NORMS		FORMAT OF RECORD		REMARKS	
1	2	3	4	5	6	7	8	9	*	D	**
					M						M C N

5.0 AUXILIARY ITEMS(Performance test of auxiliary items shall be performed on the completely assembled valve) -- Refer NOTE-7											
5.1	Positioner	Overall leakage after assembly including Nozzles leakage	MA	Leak Test (in the steady state input signal)	100 %	10%	Mfr. Standard	No leakage	--	√	P/ W
5.2	Air Filter Regulator	1. Normal air consumption 2. Overall leakage	MA	Measurement	Each type	10%	Mfr. Standard	No leakage	--	√	P/ W
5.3	Air lock relay	Performance Test	MA	Leakage test	100%	10%	Mfr. Standard	No leakage	--	√	P/ W
5.4	Electronic position transmitter(not applicable if provided integral to smart positioner)	1. Accuracy	MA	Operation	100%	10%	Approved drg/datasheet	Approved drg/data sheet	--	√	P/ W

BHEL				BIDDER/ SUPPLIER				FOR CUSTOMER REVIEW & APPROVAL			
ENGINEERING		QUALITY		Sign & Date		Sign & Date		Doc No:		Sign & Date	
Prepared by:		Name CHETAN MALIK	Checked by:	Sign & Date 10/1/2020	Name KUNDAN PRASAD	Reviewed by:	Name	Seal	Reviewed by:	Name	Seal
Reviewed by:		Name R. K. RAINA	Reviewed by:	Sign & Date 10/1/2020	Name R.K. JAISWAL	Approved by:	Name	Seal	Approved by:	Name	Seal

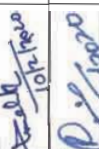
MANUFACTURER/BIDDER/ SUPPLIER NAME & ADDRESS		STANDARD QUALITY PLAN				SPEC. NO. :-		DATE: --		
		CUSTOMER :-				QP NO.: PE-QP-999-145-I.006		DATE: 10.01.2020		
		PROJECT: --				PO NO.: --		DATE: --		
		ITEM: CONTROL VALVE		SYSTEM: C&I		SECTION: C		SHEET 7 OF 9		
SL NO.	COMPONENT & OPERATIONS	CHARACTERISTIC CHECKED	CATE GORY	TYPE OF CHECK	QUANTUM OF CHECK	REFERENCE DOCUMENT	ACCEPTANCE NORMS	FORMAT OF RECORD	AGENCY	REMARKS
1	2	3	4	5	6	7	8	9	M C N	

5.5	Current to Pneumatic converter(not applicable for smart positioner)	1. Physical Verification Make/Model 2. Degree of Protection 3. Linearity	MA	Visual	100%	Approved drg/datasheet	Approved drg/data sheet	--	P/ W	
		2. Degree of Protection	MA	IP/NEMA test	Each type	Relevant Standard	Relevant Standard	--	P/ W	
		3. Linearity	CR	Measurement	10%	Approved drg/datasheet	Approved drg/data sheet	--	P/ W	
		2. Hysteresis	CR	Measurement	10%	Approved drg/datasheet	Approved drg/data sheet	--	P/ W	
5.6	Smart Positioner (As Applicable)	1. Physical Verification Make/Model 2. Degree of Protection 3. Linearity 4. Hysteresis	MA	Visual	100%	Approved drg/datasheet	Approved drg/data sheet	--	P/ W	
		2. Degree of Protection	MA	IP/NEMA test	Each type	Relevant Standard	Relevant Standard	--	P/ W	
		3. Linearity	CR	Measurement	10%	Approved drg/datasheet	Approved drg/data sheet	--	P/ W	
		4. Hysteresis	CR	Measurement	10%	Approved drg/datasheet	Approved drg/data sheet	--	P/ W	

BHEL			
ENGINEERING		QUALITY	
Prepared by:	Sign & Date	Sign & Date	Name
	10/1/2020		KUNDAN PRASAD
Reviewed by:	Sign & Date	Reviewed by:	Name
	10/1/2020		R. K. JAISWAL

BIDDER/ SUPPLIER	
Sign & Date	Sign & Date
Seal	Name
	Seal

FOR CUSTOMER REVIEW & APPROVAL			
Doc No:	Sign & Date	Name	Seal
Reviewed by:			
Approved by:			



MANUFACTURER/BIDDER/ SUPPLIER NAME & ADDRESS		STANDARD QUALITY PLAN				SPEC. NO. : --		DATE: --		
CUSTOMER : --		PE-QP-999-145-I 006				QP NO. : PE-QP-999-145-I 006		DATE: 10.01.2020		
PROJECT : --		CONTROL VALVE				PO NO. : --		DATE: --		
ITEM: CONTROL VALVE		SYSTEM: C&I				SECTION: C		SHEET 8 OF 9		
SL NO.	COMPONENT & OPERATIONS	CHARACTERISTIC CHECKED	CATE GORY	TYPE OF CHECK	QUANTUM OF CHECK	REFERENCE DOCUMENT	ACCEPTANCE NORMS	FORMAT OF RECORD	AGENCY	REMARKS
1	2	3	4	5	M 6 C/N	7	8	9	M C N	

	5. Calibration with Hand Held Communicator	MA	Measurement	Each type	Each type	Mfr. Standard	Mfr. Standard	--	√	P/W	
5.7	Electrical items (i) Limit Switches	MA	HV, IR, Continuity function	100%	100%	Approved Data sheet	Approved Data sheet	--	√	P/W	
	2.Degree of protection	MA	IP/NEMA Tests	One sample/type	One sample/Lot	Approved Data sheet	Approved Data sheet	--	√	P/W	
	(ii) Solenoids	MA	HV, IR, Continuity function	100%	10%	Approved Data sheet	Approved Data sheet	--	√	P/W	
	2.Degree of protection	MA	IP/NEMA Tests	One sample/type	One sample/Lot	Approved Data sheet	Approved Data sheet	--	√	P/W	
	(iii) Position Transmitter(if provided externally)	MA	HV, IR, Continuity function	100%	10%	Approved Data sheet	Approved Data sheet	--	√	P/W	
	2.Degree of protection	MA	IP/NEMA Tests	One sample/type	One sample/Lot	Approved Data sheet	Approved Data sheet	--	√	P/W	
6.0	PAINTING	MA	Visual and	100%	10%	Mfr. Standard	Mfr. Standard	Inspection	√	P/W	Refer Note-2

ENGINEERING				QUALITY			
Prepared by:	Sign & Date	Name	Checked by:	Sign & Date	Name	Reviewed by:	Seal
	<i>[Signature]</i>	CHETAN MALIK		<i>[Signature]</i>	KUNDAN PRASAD		
Reviewed by:	Sign & Date	Name	Checked by:	Sign & Date	Name	Reviewed by:	Seal
	<i>[Signature]</i>	R. K. RAINA		<i>[Signature]</i>	R. K. JAISWAL		

FOR CUSTOMER REVIEW & APPROVAL

BIDDER/SUPPLIER

BHEL

10/12/2020

MANUFACTURER/BIDDER/ SUPPLIER NAME & ADDRESS		STANDARD QUALITY PLAN				SPEC. NO. :-	DATE: --			
		CUSTOMER :-		QP NO.: PE-QP-999-145-I-006		DATE: 10.01.2020				
		PROJECT :-		PO NO.: --		DATE: --				
ITEM: CONTROL VALVE		SYSTEM: C&I		SECTION: C		SHEET 9 OF 9				
SL NO.	COMPONENT & OPERATIONS	CHARACTERISTIC CHECKED	CATEGORY	TYPE OF CHECK	QUANTUM OF CHECK	REFERENCE DOCUMENT	ACCEPTANCE NORMS	FORMAT OF RECORD	AGENCY	REMARKS
1	2	3	4	5	6	7	8	9	**	
		M	C/N						M C N	



7.0	PACKING	Painting	Measurement	100%	100%	Mfr. Standard	Standard	Report	P/W	V	Refer Note-3
	Soundness of Packing against transit damage	MA	Visual	100%	100%	Mfr. Standard	Mfr. Standard	Inspection Report	√		

NOTES:

- Cv test shall be conducted at FCRI/laboratory approved by Govt. Of India/BHEL approved Laboratory. Alternatively, valid Cv test certificate as mentioned in Section-C (Clause No. XII) for a similar control valve (same size, same Cv, same trim characteristics) can be accepted for a specific project subject to acceptance by Customer.
- Customer's specification for painting shall be included during project specific enquiry. In the absence of Customer's spec. for painting, vendor to obtain BHEL's approval on their painting specification / procedure.
- Sea worthy packing shall be provided, if called for in the Data sheets. Vendor to provide the following to BHELPEM for verification:
 - Photographs of valves duly placed inside the wooden box just before final packing.
 - Photographs of the wooden box (along with P.O. details mentioned) in which valves have been finally packed just before dispatch
 Clearance for dispatch of valves will be given only after receipt of the photos of valves in satisfactory condition as mentioned above.
- IBR certificates in Form III-C shall be submitted if called for in the specification/datasheet. For overseas projects where Indian standards like IBR are not acceptable to Customer, bidder to follow equivalent codes/standards followed in the respective country.
- Copies of all TC's (Test Certificates) for materials duly correlated with Heat Nos., TC's for electrical items and mechanical tests(Leak/Operation), C.O.C's(Certificates of Conformance) shall be submitted to BHEL for verification and acceptance.
- BHEL reserves the right to conduct repeat tests, if required.
- Valve manufacturer to arrange for C.O.C's(Certificates of Conformance) for the tests w.r.t. control valve accessories mentioned at Sl. No. 5 of the QAP.

LEGENDS:

*RECORDS, IDENTIFIED WITH "TICK"(✓) SHALL BE ESSENTIALLY INCLUDED BY SUPPLIER IN QA DOCUMENTATION,
 ** M: SUPPLIER/ MANUFACTURER/ SUB-SUPPLIER, C: MAIN SUPPLIER/ BHEL/ THIRD PARTY INSPECTION AGENCY, N: CUSTOMER(OWNER/END CLIENT), P: PERFORM, W: WITNESS, V: VERIFICATION, AS APPROPRIATE MA: MAJOR, MI: MINOR, CR: CRITICAL, RT: RADIOGRAPHIC TEST, UT: ULTRASONIC TEST, PT: DYE PENETRANT TEST, MT: MAGNETIC PARTICLE TEST

ENGINEERING		QUALITY	
Sign & Date	Name	Sign & Date	Name
	CHETAN MALIK		KUNDAN PRASAD
Reviewed by:	R.K. RAINA	Reviewed by:	R.K. JAISWAL

BIDDER/SUPPLIER	
Sign & Date	Seal

FOR CUSTOMER REVIEW & APPROVAL			
Doc No:	Sign & Date	Name	Seal
Reviewed by:			
Approved by:			



**TECHNICAL SPECIFICATION FOR
AUXILIARY STEAM PRESSURE REDUCING &
DESUPERHEATING STATION**

SPEC. NO.: PE-TS-426-142-N101

SECTION II

REV. NO. 00

DATE 13.01.20

COMPLIANCE CERTIFICATE

The bidder shall confirm compliance with following by signing/ stamping this compliance certificate and furnish same with the offer.

- a) The scope of supply, technical details, construction features, design parameters etc. shall be as per technical specification & there are no exclusions with regard to same.
- b) There is no other deviations w.r.t. specification other than those furnished in the 'Schedule of Technical Deviation/ Clarification'. Any other deviation, stated or implied, taken elsewhere in the offer stands withdrawn. The acceptance of the deviations is not binding on BHEL/ Customer.
- c) Bidder shall submit stamped QP on compliance basis in the event of order based on the guidelines given in the specification. In case, the bidder is supplying the item from outside India, the third party inspection shall be arranged and considered by the bidder in their offer.
- d) Any drawing/ document/ data-sheet/ calculation/ Quality plan/ Instrumentation etc. submitted along with the offer shall be considered for reference only, same shall be subject to BHEL/ Customer/Customer's Consultant approval in the event of order.
- e) The offered materials shall be either equivalent or superior to those specified in the specification. For components where materials are not specified, same shall be suitable for intended duty, all materials shall be subject to approval in the event of order.
- f) Bidder to confirm that any calculation/format required during the contract (in the event of order) to ascertain any calculated/selected value shall be furnished.
- g) Selection of valves and actuators are bidder's responsibility. Any change in selection of type of valve / sizing / percentage opening, calculations, QP, etc., if desired by BHEL / customer during approval of the documents after award of contract, without major changes in process parameters as per tender specification, shall be carried out by bidder without any commercial implication and time delay.
- h) All sub - vendors shall be subject to BHEL/ Customer/Customer's Consultant approval in the event of order.



**TECHNICAL SPECIFICATION FOR
AUXILIARY STEAM PRESSURE REDUCING &
DESUPERHEATING STATION**

SPEC. NO.: PE-TS-426-142-N101

SECTION II

REV. NO. 00

DATE 13.01.20

Tag No..... Quantity.....

Data Sheet No. PES-145-06-DS2-1

DATA SHEET-B

**DATA SHEET – C FOR CONTROL VALVE (WITH PNEUMATIC ACTUATOR)
(TO BE FILLED BY THE BIDDER AFTER THE AWARD OF CONTRACT)**

GENERAL*	PROJECT	
	SERVICE	
	LOCATION	
	DUTY	
	PIPE SIZE (inlet / outlet)	
	PIPE MATERIAL (inlet / outlet)	
BODY	MODEL NUMBER	
	TYPE OF BODY : GUIDING : NO. OF PORTS	
	BODY SIZE : PORT SIZE : DESIGN CV	
	END CONNECTION & RATING (ANSI)	
	BODY MATERIAL	
	PACKING MATERIAL SINGLE / DOUBLE	
	BONNET TYPE	
	TRIM FORM	
	TRIM MATERIAL : SEAT PLUG	
	TRIM MATERIAL : CAGE GUIDE	
	FLOW	
	OUTLET VELOCITY	
	REQUIRED LEAKAGE CLASS	
	NOISE LEVEL (dBA)	
VACUUM SERVICE		
ANTI CAVITATION TRIM		
PNEUMATIC ACTUATOR	MODEL NO. & SIZE	
	CLOSE AT : OPEN AT (Kg / Cm ² g)	
	*TRAVEL TIME FOR OPEN TO CLOSE, CLOSE TO OPEN	
	*VALVE POSN. ON SIGNAL AIR FAILURE	
	*VALVE POSN. ON SUPPLY AIR FAILURE	
ACCESSORIES	POSITIONER	
	AIR FILTER REGULATOR	
	AIR LOCK RELAY	
	POSITION LIMIT SWITCH	
	POSITION TRANSMITTER	
	SOLENOID VALVE	
	E / P CONVERTER	
	JUNCTION BOX	
	HAND WHEEL (SIDE MOUNTED)	
	LOCAL POSITION INDICATOR	
ELECTRO PNEUMATIC POSITIONER		



**TECHNICAL SPECIFICATION FOR
AUXILIARY STEAM PRESSURE REDUCING &
DESUPERHEATING STATION**

SPEC. NO.: PE-TS-426-142-N101

SECTION II

REV. NO. 00

DATE 13.01.20

Tag No..... Quantity.....

Data Sheet No. PES-145-06-DS2-1

DATA SHEET-B

**DATA SHEET – C FOR CONTROL VALVE (WITH PNEUMATIC ACTUATOR)
(TO BE FILLED BY THE BIDDER AFTER THE AWARD OF CONTRACT)**

POSITIONER	MFR. & MODEL NUMBER		
	BYPASS	GAUGES	ENCL. CLASS
	INPUT SIGNAL (Kg / Cm ²)		
	OUTPUT SIGNAL (Kg / Cm ²)		
AIR FILTER REGULATOR	MFR. & MODEL NUMBER		
	AIR SUPPLY PRESS (Kg / Cm ² g)		
	OUTPUT PRESS (Kg / Cm ² g)		
	OUTPUT GAUGE		
	FILTER SIZE		
AIR LOCK	MFR. & MODEL NUMBER		
	SET PRESS (Kg / Cm ²)		
	SUPPLY PRESS (Kg / Cm ²)		
	RESET TYPE		
	VENT PLUG		
LIMIT SWITCH	MFR. & MODEL NUMBER		
	OPEN posn	INT posn	CLOSE posn
	CONTACT TYPE		
	RATING (AC / DC)		
	ENCLOSURE CLASS		
POSITION TRANSMITTER	MFR. & MODEL NUMBER		
	TYPE		
	SUPPLY		
	OUTPUT RATING		
	ACCURACY		
	ENCLOSURE CLASS		
SOLENOID VALVE	MFR. & MODEL NUMBER		
	RATING		
	OPERATION	QUANTITY	
	COIL INSULATION CLASS		
	ENCLOSURE CLASS		
HANDWHEEL	ORIENTATION		
JUNCTION BOX	NO. OF WAYS		
	SIZE		
	CABLE GLANDS (Size / Quantity)		
	ENCLOSURE CLASS		
	BODY MATERIAL		
I/P CONVERTER	INPUT SIGNAL	POWER SUPPLY	
	SPLIT RANGE		
	ENCLOSURE CLASS		
	LINEARITY		
	HYSTERISIS		
Cu. Tubing & Fittings / per CV	25 Meters of ¼ " PVC coated Cu. Tubing, with 1 set of Fittings for connection to IA Header on one end and accessories on another end of CV		
PAINTING	COLOUR/SHADE		
	THICKNESS (DFT)		
	TYPE		
			COMPANY SEAL
			NAME
			SIGNATURE
			DATE



**TECHNICAL SPECIFICATION FOR
AUXILIARY STEAM PRESSURE REDUCING &
DESUPERHEATING STATION**

SPEC. NO.: PE-TS-426-142-N101

SECTION II

REV. NO. 00

DATE 13.01.20

SCHEDULE OF TECHNICAL DEVIATION/ CLARIFICATION

S. No.	Document Ref/ Title / Section	Page No.	Clause No.	Description	Deviation/ Clarification