



**Bharat Heavy Electricals Limited**  
**Boiler Auxiliaries Plant**  
**Ranipet - 632 406**  
**Tamil Nadu, India**  
**M&S DEPARTMENT**

**Phone:** 04172-284623

**Email:** [plramana@bhelrpt.co.in](mailto:plramana@bhelrpt.co.in)

**M&S DEPARTMENT**

BAP: M&S: PLG: ELEC

Dt: 22.11.2014

**To**

The Bidder

Dear Sir(s),

**Sub:** Electrical Petty Works at BHEL Ranipet for Two years.

**Ref:** Tender Notice No. BAP: M&S: TE: ELE: 14: 024: DT: 22.11.2014.

\*\*\*\*\*

Please find enclosed / attached non-transferable tender document containing Notice inviting tender, qualification requirements, general conditions of contract (GCC) for works, general instructions to bidders, Bill of material, scope of work etc. to offer your most competitive rates for all the items.

- 1) **Earnest Money Deposit (EMD) shall be in the form of DD.** Bidders who had already remitted one time EMD (Rs. Two lakhs) should furnish the details of cash receipt No. \_\_\_Dt. \_\_\_ With a covering letter. Tender without EMD / without reference to one time EMD will be summarily rejected.
- 2) The completed bid along with requisite EMD of **Rs. 1,00,000/- ( One Lakh only)** for the work in the form of Demand Draft / One time EMD. The Demand Draft (DD) shall be drawn in favor of "**BHEL, Ranipet**" payable at Ranipet (or) SBI, Mukundarayapuram Branch (Code: 7013), shall reach the office of the undersigned on or before **18.12.2014 at 14.30 hrs.** EMD in any other form will not be accepted.
- 3) Tenders without EMD shall be summarily rejected.
- 4) Document has to be signed by the bidder in all the pages.
- 5) Price bid has to be duly filled in and signed by the bidder in all the pages. **The bidder has to quote most competitive rates in Part – II, Price bid.**
- 6) The tender (Technical bid) will be opened on the **18.12.2014 at 14.30 hrs.** In case of opening day falls on holiday or happened to be declared as a holiday, the receipt and opening of the tender shall automatically fall on the same timing of the next working day. You / your authorized Representative may participate in the tender opening.
- 7) Clarification if any can be obtained contacting following phone No. 04172 – 284623.

Thanking you,

Yours faithfully

For and on behalf of Bharat Heavy Electricals Limited,

**DGM / M&S**

P. லக்ஷ்மி ரமணா

பி. லக்ஷ்மி ரமணா / P. LAKSHMI RAMANA  
உப. மாஹாபிரதீபக/Deputy General Manager  
அனுகூலம் என். சேவாள் விவாக / M&S Department  
பி.ஐ.ஐ.எல், பி.ஐ.பி, ராணிபேட்டை / BHEL / BAP / RANIPET-632406

Page 1 of 90

**SIGNATURE OF THE TENDERER  
WITH SEAL AND ADDRESS**

# TENDER DOCUMENT

TENDER NOTICE NO: BAP: M&S: TE: EL: 14: 024: DT: 22.11.2014

<b>Name of work</b>	Electrical Petty Works at BHEL Ranipet.
<b>Period of Contract</b>	Two Years.

Issued to M/s:

## **PART – I – TECHNICAL BID (Pages 1 to 71)**



**MAINTENANCE & SERVICES DEPARTMENT**  
**BHARAT HEAVY ELECTRICALS LIMITED**  
(A Government of India Undertaking)  
**BOILER AUXILIARIES PLANT**  
**INDIRA GANDHI INDUSTRIAL COMPLEX**  
**RANIPET – 632 406**

**SIGNATURE OF THE TENDERER  
WITH SEAL AND ADDRESS**

## CONTENTS

<b>SL. NO</b>	<b>DESCRIPTION</b>	<b>PAGE NO</b>
<b>1</b>	<b>NOTICE INVITING TENDER</b>	<b>4</b>
<b>2</b>	<b>QUALIFICATION REQUIREMENTS (QR)</b>	<b>5 to 7</b>
<b>3</b>	<b>DETAILS TO BE FILLED BY THE BIDDER</b>	<b>8</b>
<b>4</b>	<b>SCOPE OF WORK &amp; SPECIAL CONDITIONS</b>	<b>9,10</b>
<b>5</b>	<b>QUESTIONNAIRE TO FILLED BY THE BIDDER</b>	<b>10,11</b>
<b>6</b>	<b>IMPORTANT NOTE TO BIDDERS &amp; SPECIAL TERMS AND CONDITIONS TO ENQUIRY</b>	<b>12 to 14</b>
<b>7</b>	<b>GENERAL CONDITIONS OF CONTRACT FOR WORKS</b>	<b>15 to 28</b>
<b>8</b>	<b>RESERVE AUCTION</b>	<b>29 to 37</b>
<b>8</b>	<b>GENERAL INSTRUCTIONS TO BIDDERS</b>	<b>38 to 43</b>
<b>9</b>	<b>FREE ISSUE MATERIALS &amp; CERTIFICATE OF NO DEVIATION</b>	<b>44,45</b>
<b>10</b>	<b>DRAWINGS</b>	<b>46 to 49</b>
<b>11</b>	<b>TECHNICAL SPECIFICATIONS</b>	<b>50 to 53</b>
<b>12</b>	<b>UN-PRICE BID</b>	<b>54 to 71</b>
<b>13</b>	<b>PART – II – PRICE BID</b>	<b>72 to 89</b>
<b>14</b>	<b>SAFETY RULES</b>	<b>90</b>

**SIGNATURE OF THE TENDERER  
WITH SEAL AND ADDRESS**



## Bharat Heavy Electricals Limited

( A Government of India Undertaking)

**BOILER AUXILIARIES PLANT  
RANIPET – 632 406, INDIA**

Phone No:04172-284623

FAX No.:04172-241201

E-mail: plramana@bhelrpt.co.in

### MAINTENANCE & SERVICES DEPARTMENT REGISTERED POST WITH ACK.DUE

#### INVITING TENDER

Tender Notice No	<b>BAP: M&amp;S: TE: EL: 14: 024: DT: 22.11.2014</b>
Name of work	<b>Electrical Petty Works at BHEL Ranipet.</b>
Type of tender	<b>Open tender</b>
Period of contract	<b>Two Years</b>
Earnest Money Deposit (EMD) Amount	<b>Rs. 1,00,000/- (Rs. One Lakh only)</b>
Last date & Time for Receipt of the Tender	<b>18.12.2014 at 14.30 hrs</b>
Date of Technical bid Opening	<b>18.12.2014 at 14.30 hrs on wards.</b>
<b>(Please obtain updated information from the website about the latest applicable dates &amp; other changes if any in the tender contents)</b>	
Date of Price Bid Opening	Bidders whose technical bids are found acceptable will be intimated separately about the status of their offers and the date of opening of Price Bid.
Place of submission of Tender	Tender Box placed in M&S Office / BHEL –BAP. Ranipet – 632 406
Address on the Sealed Tender Cover to be:	<b>DEPUTY GENERAL MANAGER M &amp; S DEPARTMENT BHARAT HEAVY ELECTRICALS LIMITED RANIPET – 632 406 VELLORE DISTRICT TAMIL NADU</b>
Venue of the Tender Opening	M&S Conference hall
<b>Note:</b>	
1. The Tender documents can be down loaded from BHEL website ( <a href="http://www.bhel.com/tender/list_tender.php">http://www.bhel.com/tender/list_tender.php</a> ) and Govt tender web site: <a href="http://tenders.gov.in/">http://tenders.gov.in/</a> and also ___ in Central Public Procurement Portal (CPP) website: <a href="http://eprocure.gov.in/epublish/app">http://eprocure.gov.in/epublish/app</a>	
2. Interested bidders may alternately collect hard copy of tender specification documents at free of cost from M&S Dept / BHEL / Ranipet on all working days (between 10.00 to 15.00 hrs).	
3. BHEL shall not take any responsibility for delay / loss of documents or correspondence sent by courier / post.	
4. BHEL reserves the right to accept or reject any or all tenders without assigning any reasons whatsoever.	
5. All corrigenda, addenda, amendments, clarifications etc. to tender specification will be hosted in the web pages ( <a href="http://www.bhel.com">www.bhel.com</a> > <b>Tender notifications</b> > <b>view corrigendum</b> ) only and not in the news papers. <b>Bidders shall keep themselves updated with all such developments.</b>	
6. BHEL reserves the right to reject any tender on the basis of unsatisfactory performance of the bidder in any on going job or any similar job in the past.	

**SIGNATURE OF THE TENDERER  
WITH SEAL AND ADDRESS**

**QUALIFICATION REQUIREMENTS (QR) :**

**Name of work:** Electrical Petty Works at BHEL Ranipet.

**Tender Notice No:** BAP: M&S: TE: EL: 14: 024: DT: 22.11.2014

S. No	Description	Details ( To be filled by the Contractor )
1	Average annual financial turnover of the Contractor during the last 3 years ending on 31st March 2014, should be at least <b>Rs. 20.97 lakhs</b> and the bidder should submit audited balance sheet and Profit & Loss Account for the last three years (2011 – 12, 2012 – 13 & 2013-14), duly certified by chartered accountant / auditor.	2011 – 12:
		2012 – 13:
		2013 – 14:
2	Contractors having experience of successfully completed similar works (ref. Note 1 below) during the last 7 years as on 31.10.2014 should be any of <b><u>the following three categories</u></b> .	
2. a	<p><b><u>Category no:1</u></b></p> <p>Three similar completed works each costing not less than the amount equal to <b>Rs. 27.96 Lakhs</b></p>	Client : Name of work :  Value of Wok : Rs. Completion Certificate issued by :  Date of completion of work:
		Client: Name of work:  Value of Wok : Rs. Completion Certificate issued by :  Date of completion of work:
		Client: Name of work:  Value of Wok : Rs. Completion Certificate issued by :  Date of completion of work:

**SIGNATURE OF THE TENDERER  
WITH SEAL AND ADDRESS**

2.b	Two similar completed work costing not less than the amount equal to <b>Rs. 34.95 Lakhs.</b>	Client: Name of work:
		Value of Wok : Rs. Completion Certificate issued by :  Date of completion of work:
		Client: Name of work:
		Value of Wok : Rs. Completion Certificate issued by :  Date of completion of work:

**OR**

2.c	One similar completed work costing not less than the amount equal to <b>Rs. 55.92 Lakhs.</b>	Client: Name of work:
		Value of Wok : Rs. Completion Certificate issued by :  Date of completion of work:

3. Contractor should have relevant valid **Electrical EB / ES A / EA / ES B grade license** from State Electrical Licensing Board of Tamilnadu / other states for carrying out this work.

**Note1: ‘Similar Works’ mentioned in above Sl.No-2 shall mean successfully executed “electrical maintenance works in manufacturing / process industries” or successfully executed erection works of electrical equipment / Cables/ LT panels / HT panels in manufacturing/ process industries.**

Tender bids not meeting any of the above pre-qualification criteria shall be rejected and shall not be considered for further evaluation of tender.

Possession of PF registration number is not mandatory. However the successful tenderer has to register with PF authorities and furnish the registration number before first Running Account Bill.

BHEL reserves its right to reject the tender on account of unsatisfactory past performance by the bidder in other projects awarded under different enquiry.

**The work executed in the own name of the bidder only will be considered for similar works executed for meeting the eligibility criteria.**

**SIGNATURE OF THE TENDERER  
WITH SEAL AND ADDRESS**

## **Documents required for proof of QR:**

The bidders should submit documents in support of possessing Qualifying requirements as under, duly certified and stamped by their authorized signatory:

- a. Copy of Balance sheet, Profit & Loss Account duly certified & audited by Chartered Accountant) and work orders along with BOQ and completion certificates in support of the qualifying criteria.
- b. Copy of authorization letter / power of attorney of the authorized signatory of the tender document (only in case of owner of the firm is different from authorized signatory).

#### **4. Percentage Rate contract (for Schedule A):**

**The bidder shall quote a percentage above or below or at par, on the estimated value of Schedule A given in SL. No: 17 of Price Bid. The percentage quoted shall be clearly written both in words and figures. The quoted percentage will apply to the individual schedule uniformly.**

5. **For Schedule B, the bidder has to quote most competitive rates for all the items in the price bid.**
6. **The rates quoted shall be firm through out the contract period of 24 months and extended contract period also and no cost escalation is allowed on any account.**
7. **EMD should be enclosed in separate cover.**
8. **The following documents are to be enclosed along with Technical bid in a sealed cover.**
  1. **Balance sheet,**
  2. **Profit & Loss Account.**
  3. **Valid electrical license**
  4. **Experience, Value of work executed in the similar nature of work etc.,**

**Any bid without proper documentary evidence for pre-qualification shall not be considered for the further evaluation.**

9. **Price bid documents are to be enclosed in separate sealed cover.**

**SIGNATURE OF THE TENDERER  
WITH SEAL AND ADDRESS**

**Details to be filled by the Bidder**

1a	Name of applicant	
1b	Full address	
1c	Nationality	
1d	email cell phone fax	
2	Whether the firm is individual firm or Sole proprietorship firm or partner ship firm or Hindu undivided Family or association of persons or Private Limited company or Public Limited company or any other please specify.	
3	Whether the contractor has registered his workmen under employees State Insurance Act. If so, the Registration No./ Enrolment Number may be furnished.	
4	PAN no and documentary proof (Notarized copy has to be enclosed)	
5	Registration under Tamil Nadu VAT ACT, TIN number.	
6	The service tax heads under which the enlisting person registered with Excise Authorities and copy of service tax registration certificate has to be enclosed	
7	Whether the contractor has registered his workmen under Employees Provident Fund and Miscellaneous Provisions Act?	
8	Income Tax return filed acknowledgement for last 3 years has to be enclosed.	

**SIGNATURE OF THE TENDERER  
WITH SEAL AND ADDRESS**



## **BRIEF SCOPE OF WORK & SPECIAL CONDITIONS**

1. BHEL/ Ranipet is located around 120 KM north of Chennai, in Vellore district. The factory is having manufacturing facilities for Boiler auxiliaries like Electro static precipitators, Fans, Air-pre heaters.
2. There is a 11 KV receiving substation located inside the factory with 2500 KVA approved demand which is distributed for factory and office power requirements. There are around 9 manufacturing bays which are operated for two shifts. The plant is having stand by DG sets of various ratings totaling of 2500 KVA to cater to power demand during the normal (EB) power failure. There are various type of machineries available for production purpose.
3. While normal routine maintenance of these sophisticated machines and plant operation will be carried out by BHEL Employees, the petty electrical maintenance works like replacing of electrical light & Fan fittings, open wiring, concealed wiring work, fixing of Power distribution boards, maintaining of earth pits, painting of equipment and structures, supply and fixing of switches & switch boxes etc, based on the schedule of work available on price bid will have to be carried out by the contractors. The plant is operational for round the clock shifts; however the contractor generally has to carry out the petty works in general shift i.e. from 08:30 hrs to 17:30 hrs.
4. For contract workers, there is contract mess available inside the factory. The food is available at subsidized rates.
5. The period of contract is 2 years from the date of issue of work order. The billing will be done only for executed quantities. The quantity of each item in the schedule of work may vary to any extent depends up on actual requirement. The bidders are advised to visit our factory and ascertain the working conditions before quoting.
6. The contractors are requested to quote realistic and reasonable rates for all the schedules, by keeping the business volume and duration of the contract period in mind.
7. The contractor has to mobilize required men and materials to complete the work as per requirement of the BHEL.
8. BHEL reserves the right for extending the contract period based on the mutual agreement.
9. The quantities given on the Bill of materials against each schedule is tentative / approximate and is subject to variation. There may be execution of excess quantum (or) Non execution of any items given in the schedule (or) lesser execution of any items in the schedule.
10. The bidder shall note the clause (9) above before quoting.
11. The quantity indicated in the Bill of material is only tentative. The contractor has to execute any item of work irrespective of the quantity without any reservation till the total value of contract.
12. The contractor should use only the materials of brand and quality as approved by BHEL.
13. Water, Electricity and compressed air will be provided by BHEL at one point at free of cost.
14. No advance / mobilization advance will be given.
15. Quantities shown in the attached schedule are only approximate and are liable to variation without ending the contract to any compensation.

**SIGNATURE OF THE TENDERER  
WITH SEAL AND ADDRESS**

16. All works shall be carried out as per standard specifications and instructions of Engineer-in-charge.
17. All materials, color, shade, brand, etc. shall be got approved from the Engineer-in-charge before the start of the work and shall confirm to the latest IS-specifications.
18. Proper material accounting has to be maintained for all the materials supplied by BHEL.
19. Welding equipment's, consumables (welding electrodes, gas and etc.,) and cutting M/Cs with Tools, Tackles are under contractor scope.

### **QUESTIONNAIRE**

Questionnaire to be answered by the bidder by ticking the suitable boxes.

SL. No	Description	Yes	No
01	Whether the bidder has understood the scope of work and agrees to deploy required man power.		
02	Whether the bidder has agreed to all Terms & Conditions given in the tender.		
03	Whether the bidder has their own code for ESI & PF. (A copy of the certificate to be enclosed).		
04	Whether the bidder has enclosed copy of the present Service / Sales / Works contract sales Tax registration certificates. If a vendor is exempted from the registration under Service / Sales Tax, the reason there of be stated.		
05	Whether the vendor / Contractor is availing service Tax credit / VAT Credit for their inputs.		
06	Whether the vendor will submit Service Tax invoice as per the existing ACT and the rules their under.		
07	Whether the bidder agrees to Pay Wages as per Minimum wages Act, EL Wages, and Holiday Wages as per Tamil Nadu Factory rules. (Necessary proof should be submitted while claiming running bill and final bill.)		
08	Whether the PAN Number of the bidder is furnished. If exempted from IT, the exemption certificate shall be enclosed.		
09	Whether the bidder agrees to keep the validity of their offer for <b>three months</b> from the date of opening of price bid and keep the prices firm throughout the contract period.		
10	Whether the bidder agrees for the payment terms of BHEL.		
11	Whether the bidder has agreed to submit EMD of <b><u>Rs.1,00,000/-</u></b> and has submitted the same along with technical bid. (If not enclosed the tender will not be considered).		
12	Whether the bidder has agreed to submit 50 % Security Deposit before commencement of the work.		

**SIGNATURE OF THE TENDERER  
WITH SEAL AND ADDRESS**

13	Whether the Bidder has enclosed the list of their clients with addresses & contact persons.		
14	Whether the Bidder has enclosed the list of similar works carried out with supporting documents		
15	Whether the incurability / excludability of the taxes and duties in the rates offered has been clearly indicated. If the same is not done, BHEL will choose to assume the rates are inclusive only.		
16	All payments by BHEL will be made through e-payment only. The required certificate as enclosed in the tender is submitted by the bidder with Banker's signature. (Submission of e-fund transfer format is not mandatory for submission of bids).		
17	Whether the bidder has submitted the proof of average annual turnover for last 3 years for a value of Rs. 20.97 lakhs or more.		
18	Whether the bidder has visited the factory and ascertained the working conditions.		

Note: If any of the question is not applicable, please mention as "Not Applicable (NA)"

**SIGNATURE OF THE TENDERER  
WITH SEAL AND ADDRESS**

### **IMPORTANT NOTE TO BIDDRES**

**Bidders are requested to submit their offers 'in a sealed cover' consisting of three inner sealed covers such as (1) EMD cover containing DD, (2) Technical Bid cover & (3) Price Bid cover, all super scribing the name of the work, Tender Number, Due date etc.**

- 1) EMD cover shall contain requisite EMD in the form of Demand Draft (DD). Bidders who have already remitted one time EMD of Rs. 2 Lakh need not submit the DD. However they have to furnish the details of Cash Receipt No. & Date on the top of the EMD cover. Tender without EMD / One time EMD reference will be summarily rejected. EMD in any other form will not be accepted.
- 2) Technical/Qualification bid cover shall contain duly filled in qualification bid document signed by the bidder in all the pages with documentary evidences for pre-qualification such as Balance sheet, P&L A/c, experience, value of work executed in the similar nature of work etc. Any bid without proper documentary evidence for pre-qualification shall not be considered for further evaluation.
- 3) The price bid cover shall contain price bid document (BHEL format only) duly filled in and signed by the bidder in all the pages. The bidder has to quote most competitive rates for all the items in the price bid. The completed qualification bid and price bid along with requisite **EMD of Rs 1,00,000 /-** for the work in the form of Demand Draft drawn from any Nationalized bank, in favor of “ **BHEL, Ranipet** ” payable at Ranipet (or) SBI, Mukundarayapuram Branch ( Code : 7013 ) shall reach the Office of the undersigned on or before 18.12.2014 at 14.30 Hrs.

(This earnest money deposit will be refunded to the unsuccessful Bidders after finalization of the award of work. In case of successful bidder, the earnest money will be retained as part of the Security Deposit for satisfactory completion of the work in accordance with BHEL's General Conditions of Contract enclosed. No interest will be paid on the earnest money deposit. EMD by the bidder will be forfeited if i) After opening the tender / price bid the bidder revokes his tender within the validity period or increases his earlier quoted rates ii) The bidder does not commence the work within the period as per LOI / Contract. In case the LOI / Contract is silent in this regard then within 15 days after award of contract).

- 4) **The Qualification/ Technical bid will be opened on 18.12.2014 at 14.30 hrs onwards. In case of opening day falls on holiday or happened to be declared as a holiday the receipt and opening of the Tender shall automatically fall at the same timing on the next working day. Date and time of opening of the price bid shall be intimated to those bidders who have qualified in the technical bid. The bidders or their authorized agents can participate in the tender opening for which they shall bring authorization letter for attending tender opening.**
- 5) **Bidders are required to submit their price bid in the BHEL format only**
- 6) Seeking clarification on Tender Specification: Clarifications on tender specification if any may be sought by the bidders during the office hours only from the DGM/M&S- phone no -04172-284623.
- 7) All the information as called for in the various clauses and annexure of tender specification should be furnished. The details so furnished should be complete in all respects and as per the formats prescribed in the Tender specification (Statutory requirement of Contract). The bidder may have to produce original documents for verification, if so decided by BHEL.
- 8) Offers received with any deviation or without relevant information are liable to be rejected.
- 9) Price bids received in any form other than prescribed in PRICE BID are liable to be rejected.
- 10) **The tender offer should be kept valid for 3 MONTHS from the date of price bid opening** for acceptance by BHEL. No unsolicited revision in the tender offer shall be entertained after opening of tenders and till expiry of the validity period.

**SIGNATURE OF THE TENDERER  
WITH SEAL AND ADDRESS**

- 11) Quoted rates shall be firm through out the contract period and extended contract period also and no cost escalation is allowed on any account.
- 12) **The similar works executed in the own name of the bidder only will be considered for eligibility / qualification criteria.**

**SPECIAL TERMS AND CONDITIONS TO ENQUIRY**

1. BHEL reserves the right to increase or decrease the tendered quantity.
2. Lowest prices received against BHEL tenders need not be the technically acceptable one, and in that case, BHEL reserves the right not to consider the same.
3. BHEL reserves the right to negotiate or refloat the tender opened, if L1 Price is not lowest acceptable price to them inter-alia other reasons.
4. BHEL reserves the right to negotiate the L1 rate.
5. **The contract will be finalized based on the overall LOWEST value and to be awarded to single party only.**

Clarification if any can be obtained from the undersigned before submitting the offer.

Kindly acknowledge the receipt of the entire set of tender document.

Thanking you,

Yours faithfully,  
For Bharat Heavy Electricals Limited,

**DGM / M&S Department**

**13) Proof of MSE Certificate:**

**If vendor have their MSE Certificate, EMD need not to pay for this work.**

MSE suppliers can avail the intended benefits only if they submit along with the offer, attested copies of either EM II certificate having deemed validity (Five years from the date of issue of acknowledgement in EM-II) or valid NSIC certificate or EM-II certificate along with attested copy of a CA certificate (as below) where deemed validity of EM II certificate of five years has expired) applicable for the relevant financial year(latest audited). Date to be reckoned for determining the deemed validity will be the last date of bid opening (Part 1 in case of two part bid). Non submission of such documents will lead to consideration of their bid at par with other bidders. No benefit shall be applicable for this enquiry if any deficiencies in the above required documents are not submitted before price bid opening. If the tender is to be submitted through e-procurement portal, then the above required documents are to be uploaded on the portal.

Documents should be notarized or attested by a Gazettes officer.

All MSE suppliers shall continue to be in PMD with MSE status based on the EM II certificate or valid NSIC certificate. Any new supplier will be eligible for registration with BHEL as MSE supplier provided at least any one of the following documents are submitted along with application for registration.

- a) Valid NSIC certificate or
- b) Entrepreneurs Memorandum part II(EM II) certificate (valid based on deemed validity of 5 years) or

**SIGNATURE OF THE TENDERER  
WITH SEAL AND ADDRESS**

- c) EM II certificate along with attested copy of CA certificate (as per prescribed format as below applicable for the relevant financial year(latest audited) , where the deemed validity of EM II is over.

However credentials of all MSE suppliers will be verified before considering the intended benefits for MSE suppliers as per clause9ii) at the time of tender evaluation.

**Certificate by Chartered Accountant on Letter head**

This is to certify that M/s....., (hereinafter referred to as 'Company') having its registered office at..... is registered under MSMED Act 2006,(Entrepreneur memorandum No(Part-II)..... dt:.....Category:.....(Micro/Small).(Copy enclosed)

Further verified from the Books of Accounts that the investment of the company as per the latest audited financial year ..... as per MSMED Act 2006 is as follows:

1. For Manufacturing Enterprises: Investment in plant and machinery(i.e. original cost excluding land and building and the items specified by the Ministry of Small Scale Industries vide its notification No.S.O.1722( E) dated October 5, 2006:  
Rs..... Lacs
2. For Service Enterprises: Investment in equipment( original cost excluding land and building and furniture, fittings and other items not directly related to the service rendered or as may be notified under the MSMED Act, 2006.  
Rs..... Lacs

**(Strike off whichever is not applicable)**

The above investment of Rs.....Lacs is within permissible limit of Rs.....Lacs for.....Micro/Small(Strike off which is not applicable)Category under MSMED Act 2006.

Or

The company has been graduated from its original category (Micro/Small)(Strike off which is not applicable) and the date of graduation of such enterprise from its original category is..... (dd/mm/yyyy) which is within the period of 3 years from the date of graduation of such enterprise from its original category as notified vide S.O.No.3322(E) dated 01-11-2013 published in the gazette notification dated 04-11-2013 by Ministry of MSME.

Date:

(Signature)

Name:

Membership number:

Seal of Chartered Accountant:

Signature of the Tenderer with seal  
**(Authorized Signatory)**

**SIGNATURE OF THE TENDERER  
WITH SEAL AND ADDRESS**

**BHARAT HEAVY ELECTRICALS LIMITED  
BOILER AUXILIARIES PLANT  
RANIPET 632 406**

**GENERAL CONDITIONS OF CONTRACT FOR WORKS**

**SECTION – I**

**1) DESPATCH INSTRUCTIONS:**

- 1.1. This tender specification as a whole, duly furnishing all the details required and other documents as required in the following pages, shall be duly signed and sent in a sealed cover duly super scribing the name of work as given in the tender notice.
- 1.2. The tender shall be addressed to Officer inviting tender as indicated in the tender notice.
- 1.3. Tenders submitted by post shall be sent by “REGISTERED POST WITH ACKNOWLEDGEMENT DUE” and shall be posted with the due allowance for any postal delay. The tenders received after the due date and time of opening is liable to be rejected. Telegraphic offers and offers received by telex may not be considered.
- 1.4. Tenders shall be opened by authorized officer of BHEL at his office at the time and date as specified in the tender notice in the presence of such of those bidders or their authorized representatives who may be present.
- 1.5. The Tenders shall closely pursue all the clauses, specifications and drawings indicated in the tender documents before quoting. Should the bidder have any doubt the meanings of any portion of the tender specification or find discrepancies or omission in the drawings or the tender documents issued are in complete or shall require clarification on any of the technical aspect, scope of work etc., he shall at once contact the authority inviting the tender for clarification before the submission of the tender.
- 1.6. Before tendering, the bidders are advised to inspect the site of work and the environments and be well acquainted with the actual working and other prevalent conditions, facilities available, position of material and labour. No claim will be entertained later, on the ground of lack of knowledge.
- 1.7. Bidder must fill up all the schedules and furnish all the required information as per the instructions given in various sections of the tender specification. Each and every page of the Tender Specification must be signed and submitted along with the offers by the bidder in token of complete acceptance thereof. The information's furnished shall be completed by itself.
- 1.8. The bidders shall quote the rates for each item of the tender schedules in rupees and paise only. These rates shall be entered in figures as well as in words. In case of any difference in the rates quoted in figures and in words, words will be taken as the tendered rate.
- 1.9. All entries in the tender documents should be in one ink. Over-writing and corrections should be avoided. The Bidders concerned should duly sign for all corrections and over-writings.

**2) DATA TO BE ENCLOSED:**

- 2.1. Full information shall be given by the bidder in respect of the following. Non-submission of this information may lead to rejection of the offer.

**SIGNATURE OF THE TENDERER  
WITH SEAL AND ADDRESS**

**2.2.** An attested copy of the Power of Attorney, in case the tender is signed by an individual other than the sole proprietor, shall also be attached. (If it is a Company or Firm, etc., Director/Managing Partner as the case may be is required to sign).

**2.3. IN CASE OF AN INDIVIDUAL:**

His full name, address and place and nature of business shall be indicated.

**2.4. IN CASE OF PARTNERSHIP FIRMS:**

The names of all the partners and their addresses be furnished along with a copy of the partnership deed/instrument of partnership duly certified by Notary Public shall be enclosed.

**2.5. IN CASE OF COMPANIES:**

Date and place of registration including date of commencement certificate in case of public companies (certified copies of Memorandum and Articles of Association are also to be furnished) are to be furnished.

**2.6.** Nature of business carried on by the Company and the provisions of the Memorandum relating there of shall be furnished.

**2.7.** Names and particulars including addresses of the Directors and their previous experiences shall be furnished.

**2.8.** A list of tools and tackles that the bidder is having and those that will be used on this job shall be furnished.

**2.9.** In addition to the above, the particulars required in annexure shall also be furnished.

**3) EARNEST MONEY DEPOSIT ( EMD) :**

**3.1.** EMD shall be in the form of DD / Cash receipt of BHEL/ Ranipet. Bidders who had already remitted one time EMD (Rs.Two lakhs) should furnish the details of cash receipt No with a covering letter. Tender without EMD / without reference to one time EMD will be summarily rejected. In cash of Demand Draft the same shall be drawn in favour of" **BHEL, Ranipet** " payable at Ranipet (or) SBI, Mukundarayapuram Branch (Code: 7013), Ranipet -6.

**3.2.** **"No interest shall be payable by BHEL on Earnest Money or Security Deposit, if applicable, or any money due to the Contractor by BHEL."**

**3.3.** Tenders received without Earnest Money in full in the manner prescribed above are liable to be rejected.

**3.4.** The Earnest Money Deposit of the successful tenders may be retained towards part of Security Deposit.

**3.5.** In the case of unsuccessful bidders, the Earnest Money will be refunded to them within a reasonable time after finalization of the tender.

**3.6.** Earnest Money Deposit by the bidder will be forfeited as per tender documents if the bidder :

**3.7.** Fails to communicate unqualified acceptance of Letter of Intent within 15 days of date of Letter of Intent.

**SIGNATURE OF THE TENDERER  
WITH SEAL AND ADDRESS**



- 3.8. Does not commence the work within the period as per LOI / Contract. In case the LOI/Contract is silent in this regard then within fifteen days after award of contract.
- 3.9. After opening of Tender, revokes / withdraws his tender within the validity period or revises / alters his earlier quoted rates / conditions.
- 3.10. Fails to submit SD as indicated in the Letter of Intent.

#### 4) AUTHORISATION AND ATTESTATION:

Tenders shall be signed by persons duly authorized /empowered to do so. Certified copies of such authority and relevant documents shall be submitted along with the tenders.

#### 5) VALIDITY OF OFFER:

The rates in the Tender shall be kept open for acceptance for a minimum period of **THREE MONTHS** from the date of price bid opening. In case the Bharat Heavy Electricals Limited calls for negotiations such negotiations shall not amount to cancellation or withdrawal of the original offer, which shall be binding on the bidders.

#### 6) EXECUTION OF CONTRACT:

The successful bidder's responsibility under this contract commences from the date of issue of the Letter of Intent by Bharat Heavy Electricals Limited. The successful bidder shall be required to execute an agreement in the prescribed form with BHEL within a reasonable time after the acceptance of his tender and in any case before submitting the first bill for payment. The expenses for completion, stamping and registration of the agreement with prescribed authority, if necessary, shall be borne by the Contractor.

#### 7) SECURITY DEPOSIT ( SD):

7.1. Upon acceptance of tender, the successful bidder within the time specified in the letter of intent must deposit the required amount of Security Deposit for satisfactory execution of work and shall not commence work under this contract before remitting security deposit except as directed by BHEL.

7.2. **The total amount of Security Deposit shall be as follows:**

- 7.2.1. In the case of work costing up to Rs.10 lakhs – 10% of the quoted value.
- 7.2.2. In the case of work costing Rs.10 lakhs to Rs.50 lakhs – Rs.1 lakh plus 7.5% of the amount exceeding Rs.10 Lakhs.
- 7.2.3. In the case of work costing more than Rs.50 Lakhs – Rs.4 lakhs plus 5% of the amount exceeding Rs.50 Lakhs.

#### 7.3. The Security Deposit may be furnished in any one of the following forms:-

- 7.3.1. Cash (as permissible under the income tax act).
- 7.3.2. Pay order, Demand Draft in favour of BHEL.
- 7.3.3. Local cheques of Scheduled Banks, subject to realization.
- 7.3.4. Securities available from Post Offices such as National saving Certificates, Kisan Vikas Patras etc. (Certificates should be held in the name of contractor furnishing the security and duly pledged in favour of BHEL and discharged on the back).

**SIGNATURE OF THE TENDERER  
WITH SEAL AND ADDRESS**

- 7.3.5.** Bank Guarantee from Scheduled Banks / Public Financial Institutions as defined in the companies act subject to a maximum of 50% of the total security deposit value. Balance 50% has to be remitted either by cash or in the other form of security. The Bank Guarantee format should have the approval of BHEL.
- 7.3.6.** Fixed Deposit Receipt issued by Scheduled Banks / Public Financial Institutions as defined in the companies act. The FDR should be in the name of the contractor, account BHEL, duly discharged on the back.
- 7.3.7.** Security deposit can also be recovered at the rate of 10% from the running bills. However in such cases at least 50% of the security deposit (as Bank Guarantee or Demand Draft) should be remitted before start of the work and balance 50% may be recovered from the running bills till the full Security Deposit is made up.
- 7.3.8.** EMD of the successful bidder may be converted and adjusted against the security deposit on specific request by the contractor.
- 7.3.9.** Acceptance of security deposit as per clause 7.3.4 and 7.3.6 above will be subject to hypothecation or endorsement on the documents in favour of BHEL. However, BHEL will not be liable or responsible in any manner for the collection of interest or renewal of the documents or in any other matter connected therewith.
- 7.3.10.** If the value of the work done at any time exceeds the accepted agreement value, the security deposit shall be correspondingly enhanced and the extra Security Deposit shall be immediately deposited by the Contractor or recovered from payments due to him.
- 7.3.11.** Failure to deposit the Security Deposit within the stipulated time, may lead to forfeiture of Earnest Money and cancellation of the award of work.
- 7.3.12.** If any part of Security Deposit of the Contractor is held in the form of approved securities it shall be kept transferred in the name of Bharat Heavy Electricals Limited, Ranipet, in such a manner that the same can be realized fully without referring to the Contractor, BHEL shall not be responsible for any depreciation in the value of the Security while in BHEL's custody or for any loss of interest thereon.
- 7.3.13.** BHEL reserves the right to forfeiture of Security Deposit in addition to the other claims and penalties in the event of the Contractor's failure to fulfill any of the Contractual obligation including liquidation or bankruptcy of the contractor, non-payment of money payable by means of arbitration award in favour of BHEL or in the event of termination of Contract as per terms and conditions of Contract. BHEL reserves the right to set off the Security Deposit, against any claims of any other contracts with BHEL.

## **8.0 RETURN OF SECURITY DEPOSIT:**

If the Contractor performs and completes the work in all respects to the entire satisfaction of BHEL and presents an absolute "No Demand Certificate" in the prescribed form and returns properties belonging to BHEL handed over, lent or hired by him for carrying out the said works, Security Deposit will be released to the Contractor after deducting all cost of expenses or other amounts that are to be paid to BHEL under this or other contracts entered into with the Contractor. **It may be noted that in no case the Security Deposit shall be refunded/released prior to passing of final bill.**

**SIGNATURE OF THE TENDERER  
WITH SEAL AND ADDRESS**

## **9.0 REJECTION OF TENDER AND OTHER CONDITIONS**

- 9.1** The acceptance of tender will rest with BHEL which does not bind itself to accept the lowest tender or any tender and reserves to itself full rights for the following without assigning any reasons whatsoever.
- 9.1.1.** To reject any or all of the bidders.
- 9.1.2.** To award the work in part.
- 9.1.3.** Either of the contingencies stated in (9.1.2) above to modify the time for completion suitably.
- 9.2.** Conditional and Un witnessed tenders, tenders containing absurd or unworkable rates and amounts and tenders which are incomplete and otherwise considered defective and tenders not in accordance with the tender conditions, specifications, etc., are liable to be rejected.
- 9.3.** If a bidder expires after the submission of his/her tender or after the acceptance of his/her tender, BHEL may at their discretion cancel such tender. If a partner of a firm expires the submission of the tender or after the acceptance of the tender, BHEL may cancel such tender at their discretion unless the firm retains its character.
- 9.4.** BHEL will not be bound by any power of Attorney granted by the bidder or by changes in the composition of the firm made subsequent to the execution of the Contract. They may, however recognize such power of Attorney and changes after obtaining proper legal advice, the cost of which will be chargeable to the contractor concerned.
- 9.5.** If the bidder deliberately gives wrong information in his tender, BHEL reserves the right to reject such tender at any stage or cancel the contract, if awarded. The Earnest Money/Security Deposit /any other money due shall also be forfeited.
- 9.6.** Canvassing in any form in connection with the tender is strictly prohibited and the tender submitted by the contractor's who resort to canvassing in any form are liable to rejection.
- 9.7.** Should a bidder or contractor or in the case of a firm or company of contractor's one or more of its partners/share holders/Directors have a relation or relations employed in BHEL, the authority inviting tender shall be informed of the fact along with the offer, failing this BHEL may, at its sole discretion reject the tender or cancel the contract and forfeit the Earnest Money/Security Deposit.
- 9.8.** The successful bidder should not sub-contract the part or complete work detailed in the tender specification undertaken by him without written permission of BHEL. The bidder is solely responsible to BHEL for the work awarded to him.
- 9.9.** No deviation from the tender specification shall be acceptable to BHEL. Bidders shall confirm their unqualified acceptance of the terms and conditions by giving an undertaking to this effect in a separate letter as specified by BHEL.

**SIGNATURE OF THE TENDERER  
WITH SEAL AND ADDRESS**

## SECTION – II

### **10.1 DEFINITION:**

The following terms shall have the meaning hereby assigned to them except where the context otherwise requires.

**10.2 BHEL or (B.H.E.Ltd)** shall mean Bharat Heavy Electricals Limited a Company registered under Indian Companies Act 1956, with its Registered Office at BHEL House, Siri fort, New Delhi 110 049 or its Authorized Officers or its Resident Engineer or other employees authorized to deal with any matters with which these persons are concerned on its behalf.

### **10.3 “GENERAL MANAGER”**

Shall mean the officer in Administrative charges of contracting unit of BHEL.

**10.4 “ENGINEER”** or “ENGINEER IN CHARGE” shall mean Engineer who is in-charge for the works referred.

**10.5 “SITE”** shall mean the place or places at which the plants/equipments are to be erected and services are to be performed as per the specification of this contract.

**10.6 “CONTRACTOR”** shall mean the individual, firm or company who enters in to this contract with BHEL and shall include their executors, administrators and successor and permitted assignees.

**10.7 “CONTRACT”** or “CONTRACT DOCUMENT” shall mean/and include the agreement or work order, the accepted appendices of rates, schedules, quantities, if any and general conditions of contract, the special conditions of contract, instructions to the bidders, the drawings, the technical specifications, the special specifications, if any, the tender documents and the Letter of Intent/Acceptance Letter issued by BHEL. Any conditions or terms stipulated by the contractor in the tender document or subsequent letters shall not form part of the contract unless specially accepted in writing by BHEL, in the Letter of intent and incorporated in the agreement.

**10.8 “GENERAL AND SPECIAL CONDITIONS OF CONTRACT”** shall mean the “Instructions to Bidders and General and Special Conditions of Contract” pertaining to the work for which the bidders are called for.

**10.9 “TENDER SPECIFICATIONS”** shall mean the “SPECIFIC CONDITIONS, Technical specifications, appendices, site information’s and drawings” pertaining to the work in which the bidders are required to submit their offer, Individual specification number will be assigned to each tender specification..

**10.10 “TENDER DOCUMENTS”** shall mean the General and Special Conditions of Contract (10.8) and tender specification (10.9).

**10.11 “LETTER OF INTENT”** shall mean the intimation by a letter to the bidder that the tender has been accepted in accordance with provisions contained in that letter. The responsibility of the contractor commences from the date of issue of this letter and all the terms and conditions of contract are applicable from this date.

**10.12 “COMPLETION TIME”** Shall mean the period by date specified in the acceptance of tender or date mutually agreed upon for handing over of the erected equipment/plant which is found acceptable by the Engineer being of required standard and conforming to the specifications of the contract.

**10.13 “PLANT”** shall mean and cannot the entire assembly of the plant and equipments covered by the

**SIGNATURE OF THE TENDERER  
WITH SEAL AND ADDRESS**

contract.

**10.14 "EQUIPMENT"** shall mean all equipments, machinery, materials, structural, electrical and their components of the plant covered by the contract.

**10.15 "TESTS"** shall mean and include such test or tests to be carried out on the part of the contractor as are prescribed in the contract or considered necessary by BHEL in order to ascertain the quality, workmanship, performance and efficiency of the contract work or part thereof.

**10.16 "APPROVED" "DIRECTED" or "INSTRUCTED"** shall mean approved, directed or instructed by BHEL.

**10.17 "WORK OR CONTRACT WORK"** shall mean and include supply of all categories of labour specified consumables, tools and tackles required for complete and satisfactory site transportation handling, stocking, storing, erecting, testing, and commissioning of the equipments to the entire satisfaction of BHEL.

**10.18 "SINGULAR AND PLURAL ETC"** works carrying singular number shall also include plural and vice versa, where the context so required. Words importing the masculine gender shall be taken to include the feminine gender and words imparting persons shall include any company or association or body of individuals, whether incorporated or not.

**10.19 "HEADINGS"**

The headings in these general conditions are solely for the purpose of facilitating reference and shall not be deemed to be part thereof or be taken into consideration in the interpretation or construction thereof or of the contract.

**10.20 "MONTH"** shall mean calendar month, unless specified otherwise in the tender.

**10.21 "WRITING"** shall include any manuscript typewritten or printed statement under the signature of BHEL.

**10.22 LAW GOVERNING THE CONTRACT AND COURT JURISDICTION**

The contract shall be governed by the Law for the time being in force in the Republic of India, and shall be subject to the Jurisdiction of the courts having Jurisdiction over RANIPET (VELLORE Dist, Tamil Nadu).

**10.23 ISSUE OF NOTICE:**

The Contractor shall furnish to the BHEL ENGINEER the name, designation and address of his authorized agent and all complaints, notices, communication and reference shall be deemed to have been duly given to the contractor or his authorized agent or left or posted to the address of either the contractor or of his representative and shall be deemed to have been so give in the case of posting on the day on which they would have reached such address in the ordinary course of post or on which they were so delivered of / or left.

**10.24 USE OF LAND:**

No land belonging to BHEL or their customer under temporary possession of BHEL shall be occupied by the Contractor without the written permission of BHEL.

**11 COMMENCEMENT OF WORKS:**

**SIGNATURE OF THE TENDERER  
WITH SEAL AND ADDRESS**

- 11.1** The Contractor shall commence the works within the time indicated in the Letter of Intent from BHEL and shall proceed with the same with due expedition without delay.
- 11.2** If the successful bidder fails to start the work within the stipulated time, BHEL, at his sole discretion will have the right to cancel the contract. His earnest money and/or Security Deposit with BHEL will stand forfeited without any further reference to him without prejudice to any and all of BHELs other rights and remedies in this regard.
- 11.3** All the works shall be carried out under the direction and to the satisfaction of BHEL.
- 11.4** The erected/constructed plant or work performed under this contract shall be taken over when it has been completed in all respects and/or satisfactorily put in to operation at site.
- 12 MODE OF PAYMENT AND MEASUREMENT OF THE WORK COMPLETED:**
- 12.1** All payments due to the contract shall be paid through E-PAYMENT (EFT / RTGS) only. The contractor has to furnish acceptance for e-payment, duly indicating the bank account details in the prescribed format.
- 12.2** For Progress running bill payment :
- The contractor shall present detailed measurement working sheets, in quadruplicate, duly indicating all relevant details based on technical documents and connected drawings for work done during the month/period under various categories in line with terms of payment as per letter of intent. The basis of arriving at the quantities/weight shall be the relevant documents and drawings released by BHEL.
- 12.3** These measurement working sheets will be checked and vetted by BHEL Engineers and quantities and percentage eligible for payment under various groups shall be decided by BHEL engineers. The abstract of quantities and percentage so arrived based on the terms of payment shall be entered in Measurement Book and signed by both the parties.
- 12.4** Based on the above quantity, contractor shall prepare the bills in prescribed Performa and work out the financial value. These will be entered in Measurement Book and signed by both the parties and paid duly effecting recoveries due.
- 12.5** All recoveries due from the contractor for the month/period shall be effected in full from the corresponding running bills unless specific approval from the competent authorities is obtained otherwise.
- 12.6** Measurement shall be restricted to that for which it is required to ascertain the financial liability of BHEL under this contract.
- 12.7** The measurement shall be taken jointly by persons duly authorized on the part of BHEL and by the contractor.
- 12.8** The contractor shall bear the expenditure involved, if any, in making the measurement. The contractor shall, without extra charges provide all the assistance with appliances and other things necessary for measurement.
- 12.9** If, at any time due to any reason, whatsoever, it becomes necessary to re-measure the work done in full or in part, the expenses towards such re-measurements shall be borne by the contractor.
- 12.10** Passing of measurement as per bills does not amount to acceptance of the completion of the work mentioned. Any left out work has to be completed if pointed out at a later date by BHEL.

**SIGNATURE OF THE TENDERER  
WITH SEAL AND ADDRESS**

**12.11.** Final measurement bill shall be prepared in the final bill preformed prescribed for the purpose based on the certificate issued by BHEL Engineer that entire work as stipulated in the tender specification has been completed in all respects to the entire satisfaction of BHEL. Contractors shall give unqualified „No Due and „No Demand certificate. All the tools and tackles loaned to them should be returned in condition satisfactory to BHEL. Quantities/Weight erected shall be prepared and paid, within a reasonable time after completion of work. After payment of final bill, only guarantee obligation percentage shall remain unpaid which shall be released in accordance with terms of payment. The final bill quantities and financial value shall also be entered in Measurement Book and signed by both the parties to the contract.

### **13 RIGHTS OF BHEL**

BHEL reserves the following rights in respect of this contract without entitling the contractor for any compensation.

**13.1** To get the work done through other agency at the risk and cost of the Contractor, in the event of Contractor's poor progress, or inability to progress the work, persistent disregard in instruction of BHEL, assignment transfer, subletting of the contract without permission of BHEL, non fulfillment of any contractual obligation etc., and to recover compensation for such losses from the contractor including BHELs supervision charges and overheads from Security Deposit / other dues.

**13.2** To withdraw any portion of work and/or to restrict/alter quantum of work as indicated and get it done through other agency and/or with departmental labour to suit BHEL's commitment to its customer or in case BHEL decides to advance the date of completion due to other emergency reasons/BHELs obligation to its customer.

**13.3** To terminate the contract after due notice to cause forfeiting of Security Deposit and recover the loss sustained in getting the balance work done through other agencies in addition to liquidated damages in the event of:

- 1) Contractor's continued poor progress.
- 2) Withdrawal from or abandonment of the work before completion of the work.
- 3) Corrupt act of contractor.
- 4) Insolvency of the contractor.
- 5) Persistent disregards to the instructions of BHEL.
- 6) Assignment transfer, sub-letting of the contract without BHEL's permission.
- 7) Non-fulfillment of any contractual obligations.

**13.4** To recover any money due from the contractor from any money due to the contractor under this contract or any other contract or from the Security Deposit.

**13.5** To claim compensation for losses sustained including BHEL's supervision charges and overheads for completion on termination of contract and to impose penalty for delay in completion of the work at the rate of ½% of the contract value per week of delay or part thereof subject to a ceiling of 10% of contract value.

**13.6** To terminate the contract or to restrict the quantum of work and pay for the portion of work executed in case BHEL's contracts with their customers are terminated for any reason.

**SIGNATURE OF THE TENDERER  
WITH SEAL AND ADDRESS**

- 13.7** To affect recovery from any amount due to the contractor under this or any other contractor in any other form the moneys BHEL is forced to pay to anybody, due to contractor's failure to fulfill any of his obligation.
- 13.8** To restrict or increase the quantity and nature of work to suit the site requirements since the tender specification is based on preliminary documents and quantities furnished there in are indicative and approximate and the rates quoted shall not be subject to revision.
- 13.9** To deploy BHEL's fitters, welders, operators and technicians in case of emergency/poor progress/deficiency in skill on the part of employees of contractor's and to recover the expenditure on account of the same from contractor's bills.
- 13.10** While every endeavor will be made by BHEL they cannot guarantee un-interrupted work to the contractor due to conditions beyond their control. Contractor will not be entitled for any compensation extra payment on his account.
- 13.11** In the event of any dispute of any nature, the decision of BHEL shall be final and binding on the contractor.

**14) RESPONSIBILITIES OF THE CONTRACTOR IN RESPECT OF LOCAL LAWS, EMPLOYMENT OF WORKERS Etc.**

The following are the responsibilities of the Contractor in respect of observation of local laws, employment of personnel, payment of taxes etc.

- 14.1** As far as possible unskilled workers shall be engaged from the local areas in which the work is being executed.
- 14.2** The contractor at all times during the continuance of this contract shall, in all his dealings with local labour for the time being employed on or in connection with the work, have due regard to all local festivals, religious and other customs.
- 14.3** The contractor shall comply with all state and Central Laws, Statutory Rules, Regulations etc., inclusive of those regarding labour and industrial laws which are applicable from time to time and they shall comply with the provisions of the said labour legislations, rules and regulations framed under the provisions of Employees Provident Fund and Miscellaneous Provisions Act 1952 shall be strictly followed.
- 14.4** The contractor shall pay all taxes, including sales Tax on works contract if any fees, license, charges, deposits duties, tool royalty commissions or other charges which may be leviable on account of any of his operations in execution of the contract in case BHEL is forced to pay any of such taxes. BHEL shall have the right to recover the same from the contractor either from his bills or other wise as deemed fit.
- 14.5** The contractor shall be responsible for provision of health and sanitary arrangements (more particularly described in Contract Labour Regulation & Abolition Act) safety precautions etc., as may be required for safe and satisfactory execution of the contract.
- 14.6** The contractor shall be responsible for providing proper accommodation including adequate medical facilities for the personnel employed by him.
- 14.7** The contractor shall be responsible for the proper behavior and observance of all regulations by the staff employed by him.

**SIGNATURE OF THE TENDERER  
WITH SEAL AND ADDRESS**



- 14.8** The contractor shall ensure that no damage is caused to any person/property of other parties working at site. If any such damage is caused it is the responsibility of the contractor to make good the losses or compensate for the same.
- 14.9** All the properties/equipments/components of BHEL their client loaned with or without deposit to the contractor in connection with contract shall remain the properties of BHEL/their client. The contractor shall use such properties for purpose of execution of this contract, all such properties/equipments/components shall be deemed to be in good condition when received by the Contractor's unless he notifies within 48 hours to the contrary. The Contractor shall return them in good condition as and when required by BHEL/their client. In case of non-return, loss, damage, repairs etc, the cost thereof, as may be fixed by the site Engineer, will be recovered from the Contractor.
- 14.10** It is not obligatory on the part of BHEL to supply any tools and tackles or other materials other than those specifically agreed to do so by BHEL. However, depending upon the availability/ possibility BHEL's customer's handing equipment and other plants may be made available to the contractor on payment of the hire charges/free of charges, as fixed subject to the conditions laid down by BHEL/Customer from time to time. Unless paid in advance such hire charges if applicable shall be recovered from contractor's bills/security deposit in one installment.
- 14.11** The Contractor shall fully indemnify BHEL against all claims of whatsoever nature arising during the course of erection/construction/performing work under the contract.
- 14.12** In case the Contractor is required to undertake any work outside the scope of this contract the rate payable shall be those mutually agreed upon.
- 14.13** Any delay in completion of works/non-achievement of periodical targets, due to reasons attributable to the contractor, the same will have to be compensated by the Contractor either by increasing manpower and resources or by working extra hours and/or by working more than one shift. All these are to be carried out by the contractor at no extra cost.
- 14.14** The contractor shall arrange and co-ordinate his work in such a manner as to cause no hindrance to other agencies working in the same premises.
- 14.15** All safety rules and codes applied by the client/BHEL at site shall be observed by the contractor without exception. The contractor shall be responsible for the safety of the equipment/material and works to be performed by him and shall maintain all light, fencing guard's signs etc, or other protection necessary for the purpose. Contractor shall also take such additional precautions as may be indicated from time to time by the Engineer with a view prevent pilferage, accidents, fire hazards and due precautions shall be taken against fire hazards and atmospheric conditions. Suitable number of clerical staff, watch and ward, store keepers to take care of equipment, materials and construction tools and tackles shall be posted at site by the contractor till the completion of the work under this contract. The contractor shall arrange for such safety devices as are necessary for such type of work and carry out the requisite site tests of handling equipments, lifting tools, tackles, etc., as per prescribed standards and practices.
- 14.16** The contractor will be directly responsible for payment of wages to his workmen. A pay roll sheet giving all the type payments given to the workers and duly signed by the contractor's representative should be furnished to BHEL Site office on or before 15th of every succeeding month.
- 14.17** In case of any class of work for which there is no such specification as laid down in the Contract, such work shall be carried out in accordance with the instructions and requirements of the Engineer.

**SIGNATURE OF THE TENDERER  
WITH SEAL AND ADDRESS**

- 14.18** No levy of payment or charge made or imposed shall be impeached by reason of any clerical error or by reason of any mistake in the amount levied or demanded or charged.
- 14.19** Also no idle labour charges will be admissible in the event of any stoppage caused in the work resulting contractor's labour being rendered idle due to any cause at any time.
- 14.20** The contractor shall take all reasonable care to protect the materials and work till such time the plant/equipment has been taken over by BHEL/their client.
- 14.21** Contractor shall not stop the work or abandon the site for whatsoever reason or dispute, excepting for force major conditions. All such problems/dispute shall be separately discussed and settled without affecting the progress of work. Such stoppage or abandonment shall be treated as breach of contract and dealt with accordingly.

**15) CONSEQUENCES OF CANCELLATION:**

- 15.1** Whenever BHEL exercises its authority to terminate the contract/withdraw a portion of work under the clause 13 they may complete the work by any means. In the event of the cost of completion as certified by the site Engineer which is final and conclusive being less than the contract cost, the advantage shall accrue to BHEL and that if the cost of completion exceeds the moneys due to the contractor under the contract, the contractor shall either pay the excess amount ordered by BHEL or the same shall be recovered from the contractor by any other means. This will be in addition to the forfeiture of Security Deposit and recovery of liquidated damages as per the relevant clauses.
- 15.2** In case BHEL completes the work under the provision of this condition, the cost of such Completion to be taken into account in determining the excess cost to be charged to the contract under this condition, shall consist of materials purchased and/or labour provided by BHEL with an addition of such percentage to cover supervision and establishment charges as may be decided by BHEL.

**16) INSURANCE:**

- 16.1** It is sole responsibility of the contractor to insure his workmen against accidents and injury while at work as required by relevant Rules and to pay compensation, if any, to workmen as per workmen's Compensation Act. The work will be carried out in a protected area and all the rules and regulations of the client/BHEL in the area of project which are in force from time to time will have to be followed by contractor.
- 16.2** If due to negligence and/or non-observance of safety and other precautions, any accident/injury occurs to any other persons/public, the contractor shall have to pay necessary compensation and other expenses if so decided by the appropriate authorities.
- 16.3** If due to contractor's carelessness, negligence of non-observance of safety precautions damage to BHELs /customers property and personnel should occur and if BHEL is unable to recover in full cost from the insurance company, the same will be recovered from the contractor.
- 16.4** It shall be the responsibility of the contractor to provide security arrangement for the materials belonging to BHEL and handed over to the contractor for erection/transportation till the same are taken over by BHEL after erection/returned to BHEL stores.

**17) STRIKES & LOCKOUTS:**

- 17.1** The contractor will be fully responsible for the entire dispute and other issues connected with his labor.

**SIGNATURE OF THE TENDERER  
WITH SEAL AND ADDRESS**

In the event of the contract labor resorting to strike or the contract resorting to lock-out and if the strike or lock-out declared is not settled within a period of one month, BHEL, shall have the right to get the erection work executed employing its own labor or through any agencies or both and the cost so incurred by BHEL be deducted from the contractor's bills.

**17.2** For any purpose whatsoever the employees of the contractor shall not be deemed to be in the employment of BHEL.

**18) FORCE MAJEURE:**

**18.1** The following shall amount to FORCE MAJEURE :

Act of God or of any Government, War, Sabotage, Riots, Civil commotion, Police action revolution, Flood, Fire, Cyclones, Earth quake and epidemic and other similar causes over which the contractor has no control.

**18.2** If the contractor suffers delay in the due execution of the contractual obligation due to delays caused by FORCE MAJEURE as defined above, the agreed time of completion of the job covered by this contract or the obligation of contractor shall be extended by a period of time equal to the period of delay provided that on the occurrence of any such contingency the contractor immediately reports to BHEL in writing the causes of delay and the contractor shall not be eligible for any compensation.

**19) ARBITRATION:**

Except where otherwise provided for in the contract all questions and disputes relating to the meaning of the specifications, designs, drawings and instructions herein before mentioned and as to the quality of workmanship or materials used on the work or as to any other question, claim, right, matter or thing whatsoever in anyway arising out of or relating to the contract, designs, drawings, specifications, estimates, instructions, orders or these conditions or otherwise concerning the work or failure to execute the same whether arising during the progress of the work or after the completion or abandonment thereof shall be referred to the sole arbitration of the General Manager of BHEL and if General Manager is unable or unwilling to act, to the sole arbitration of some other person appointed by the General Manager, willing to act as such arbitrator.

The cases referred to arbitration shall be other than those for which the decision of the Accepting officer or Engineer-in-charge as the case may be is expressed in the contract to be final and conclusive. There will be no objection if the arbitrator so appointed is an employee of BHEL and that he had to deal with the matters to which the contract relates and that in the course of his duties as such he had expressed views on all or any of the matters in dispute or difference.

The arbitrator to whom the matter is originally referred being transferred or vacating his office or being unable to act for any reason, such General Manager as aforesaid at the time of such transfer, vacation of office or inability to act shall appoint another person to act as an arbitrator in accordance with the terms of the contract. Such person shall be entitled to proceed with the reference from the stage at which it was left by his predecessor.

Subject as aforesaid the provision of the Arbitration Act 1940 or any statutory modification or reenactment thereof and the rules made there under and for the time being in force shall apply to the arbitration proceeding under this clause.

It is a term of the contract that the party involving arbitration shall specify the dispute or dispute to be referred to arbitration under this clause together with the amount or amounts claimed in respect of each such dispute.

**SIGNATURE OF THE TENDERER  
WITH SEAL AND ADDRESS**

The arbitrator(s) may from time to time with consent of the parties enlarge the time, for making and publishing the award.

The work under the contractor shall, if reasonably possible, continue, during the arbitration proceedings and no payment due or payable to the contractor shall be withheld on account of such proceedings.

The arbitrator shall be deemed to have entered on the reference on the date he issues notice to both the parties fixing the date of first hearing.

The arbitrator shall give a separate award in respect of each dispute or difference referred to him.

The venue of arbitration shall be such place as may be fixed by the Arbitrator in his sole discretion. The award of the Arbitrator shall be final conclusive and binding on all parties to this contracts.

In the event of disputes or differences arising between one public sector and a Government Department or between two public sector enterprises the above stipulations shall not apply, the provisions of BPE Office memorandum No.BPE/CL/001/76 MAN/2(1.10)76-BPE (GM-1)dated 1<sup>st</sup> January 1976 or its amendments for arbitration shall be applicable.

## REVERSE AUCTION

- 1) BHEL reserves the right to go for reverse auctioning among the technically qualified bidders who have been sort listed after technical bid evaluation.
- 2) “BHEL reserves the right to go for Reverse Auction (RA) instead of opening the sealed envelope price bid, submitted by the bidder. This will be decided after techno commercial evaluation. All bidders to give their acceptance for participation in RA.

Non-acceptance to participate in RA may result in non-consideration of their bids, in case BHEL decides to go for RA.

In case BHEL decides to go for Reverse Auction, only those bidders who have given their acceptance to participate in RA will be allowed to participate in the Reverse Auction. Those bidders who have given their acceptance to participate in Reverse Auction will have to necessarily submit “online sealed bid” in the Reverse Auction. Non-submission of "online sealed bid" by the bidder will be considered as tampering of the tender process and will invite action by BHEL as per extant guidelines in vogue.”

### TERMS & CONDITIONS OF REVERSE AUCTION

Against Electrical petty works at **BHEL, Ranipet**, BHEL may resort to “REVERSE AUCTION PROCEDURE” i.e., ON LINE BIDDING (THROUGH A SERVICE PROVIDER). The philosophy followed for reverse auction shall be English Reverse (No ties).

- 1) For the proposed reverse auction, technically and commercially acceptable bidders only shall be eligible to participate.
- 2) Those bidders who have given their acceptance for Reverse Auction (quoted against this tender enquiry) will have to necessarily submit „online sealed bid” in the Reverse Auction. Non-submission of „online sealed bid” by the bidder for any of the eligible items for which techno-commercially qualified, will be considered as tampering of the tender process and will invite action by BHEL as per extant guidelines in vogue.
- 3) BHEL will engage the services of a service provider who will provide all necessary training and assistance before commencement of on line bidding on internet.
- 4) In case of reverse auction, BHEL will inform the bidders the details of Service Provider to enable them to contact & get trained.
- 5) Business rules like event date, time, bid decrement, extension etc. also will be communicated through service provider for compliance.
- 6) Bidders have to fax the Compliance form (annexure II) before start of Reverse auction. Without this, the bidder will not be eligible to participate in the event.
- 7) In line with the NIT terms, BHEL will provide the calculation sheet (e.g., EXCEL sheet) which will help to arrive at “Total Cost to BHEL” like Packing & forwarding charges, Taxes and Duties, Freight charges, Insurance, Service Tax for Services and loading factors (for non-compliance to BHEL standard Commercial terms & conditions) for each of the bidder to enable them to fill-in the price and keep it ready for keying in during the Auction.
- 8) Reverse auction will be conducted on scheduled date & time.

**SIGNATURE OF THE TENDERER  
WITH SEAL AND ADDRESS**

- 9) At the end of Reverse Auction event, the lowest bidder value will be known on auction portal.
- 10) The lowest bidder has to fax/e-mail the duly signed and filled-in prescribed format for price breakup including that of line items, if required, (Annexure VII) as provided on case-to-case basis to Service provider within two working days of Auction without fail.
- 11) In case BHEL decides not to go for Reverse Auction procedure for this tender enquiry, the Price bids and price impacts, if any, already submitted and available with BHEL shall be opened as per BHEL's standard practice.
- 12) Bidders shall be required to read the "Terms and Conditions" section of the auctions site of Service provider, using the Login IDs and passwords given to them by the service provider before reverse auction event. Bidders should acquaint themselves of the „Business Rules of Reverse Auction“ , which will be communicated before the Reverse Auction.
- 13) If the Bidder or any of his representatives are found to be involved in Price manipulation/ cartel formation of any kind, directly or indirectly by communicating with other bidders, action *as per extant BHEL guidelines*, shall be initiated by BHEL and the results of the RA scrapped/ aborted.
- 14) The Bidder shall not divulge either his Bids or any other exclusive details of BHEL to any other party.
- 15) In case BHEL decides to go for reverse auction, the H1 bidder (whose quote is highest in online sealed bid) may not be allowed to participate in further RA process.
- 16) BHEL reserves the right to negotiate with the L1 tenderer emerged out of Reverse Auction if the L1 amount is more than the estimated amount.

## BUSINESS RULES FOR REVERSE AUCTION

**SCOPE:** Electrical petty works at BHEL, Ranipet

Bidders should please go through the guidelines given below and submit acceptance of the same.

1. **SCHEDULE FOR REVERSE AUCTION:** The Reverse Auction scheduled date will be informed later.
  - **Online Sealed bid** : **Will be informed later.**
  - **Online Reverse Auction** : **Will be informed later.**
2. **AUCTION EXTENSION TIME:** If a bidder places a bid in the last 10 minutes of closing of the Reverse Auction and if that bid gets accepted, then the auctions duration shall get extended automatically for another 10 minutes, for the entire auction (i.e. for all the items in the auction), from the time that bid comes in. Please note that the auto-extension will take place only if a bid comes in those last 10 minutes and if that bid gets accepted as the lowest bid. If the bid does not get accepted as the lowest bid, the auto-extension will not take place even if that bid might have come in the last 10 minutes. In case, there is no bid in the last 10 minutes of closing of Reverse Auction, the auction shall get closed automatically without any extension. However, bidders are advised not to wait till the last minute or last few seconds to enter their bid during the auto-extension period to avoid complications related with internet connectivity, network problems, system crash down, power failure, etc. The above process will continue till completion of Reverse Auction.
3. **BID PRICE:** The Bidder has to quote the total lump sum price (inclusive of design, fabrication supply to site, erection and all taxes and duties) for the Items specified in *Annexure I*. & as per excel working sheet.

Note: For the consideration of L1 bidder, the bid value shall be reduced by loading amount, if applicable.
4. **BIDDING CURRENCY AND UNIT OF MEASUREMENT:** Bidding will be conducted in Indian rupees for the scope and the specifications mentioned in *Annexure- I* & as per excel working sheet.
5. **VALIDITY OF BIDS:** Price shall be valid for 90 days from the date of reverse auction. These shall not be subjected to any change whatsoever.
6. **LOWEST BID OF A BIDDER:** In case the bidder submits more than one bid, the lowest bid at the end of Online Reverse Auction will be considered as the bidder's final offer to execute the work.
7. **POST AUCTION PROCEDURE:** BHEL will proceed with the Lowest Bid in the Reverse Auction for further processing.
8. **PROCEDURE OF REVERSE AUCTIONING :**
  - i. **Online Sealed Bid:** This duration of online sealed bid will be {...} minutes. All bidders to submit their online sealed bids during this period.
  - ii. **Online Reverse Auction:** The „opening price“ i.e. start price for RA and „bid decrement“ will be decided by BHEL.

**SIGNATURE OF THE TENDERER  
WITH SEAL AND ADDRESS**

- iii. If BHEL decides the lowest online sealed bid as the starting price, then the lowest bidder in online sealed bid shall be shown as current L1 automatically by the system and no acceptance of that price is required. System shall have the provision to indicate this bid as current L1.
  - iv. Bidders by offering a minimum bid decrement or the multiples thereof can displace a standing lowest bid and become "L1" and this continues as an iterative process.
  - v. After the completion of the online reverse auction, the Closing Price (CP) shall be available for further processing.
9. If no bid is received in the auction system/ website within the specified time duration of the online RA, then BHEL will scrap the online reverse auction process and proceed with the conventional mode of tendering (opening of the envelope sealed bids earlier submitted by the bidders).

In cases where no bidder accepts the start price, the RA may be treated as failed and sealed envelope price bids of all the techno-commercially qualified bidders shall be opened and the tender processed accordingly. Wherever the techno-commercially acceptable bidder(s) had agreed to participate in the RA and had failed to submit the online sealed bid, the envelope sealed bids of such bidder(s) shall not be entertained.

Wherever, the evaluation is done for individual items of the package, and no bid is received for some of the item(s), RA will be considered as failed for these item(s), re-reverse auction/ retendering will be conducted for these items.

10. Only those bidders who have submitted the „online sealed bid“ within the scheduled time shall be eligible to participate further in RA process. However, the H1 bidder (whose quote is highest in online sealed bid) may not be allowed to participate in further RA process.
11. Any commercial/ technical loading shall be intimated to bidders prior to RA. The excel sheet provided in this regard shall cover all these aspects. Commercial/ technical loading if any, shall be added by the respective bidder in its price during online sealed bid & Online Reverse Auction. Modalities of loading & de-loading shall be separately intimated to the bidders.
12. Computerized reverse auction shall be conducted by BHEL (through M/s {Service Provider}), on pre-specified date, while the bidders shall be quoting from their own offices/ place of their choice. Internet connectivity shall have to be ensured by bidders themselves.

During the RA if a bidder is not able to bid and requests for extension of time by fax/ e-mail/ phone then time extension of additional 15 minutes will be given by the service provider provided such requests come before 5 minutes of auction closing time. However, only one such request per bidder can be entertained.

Despite this extension if bidder fails to upload his prices due to extreme case of failure of Internet connectivity, (due to any reason whatsoever may be) it is the bidders" responsibility/ decision to send fax communication immediately to M/s. {Service provider}, furnishing the price the bidder wants to bid online with a request to the service provider to upload the faxed price on line so that the service provider will up load that price on line on behalf of the Bidder. It shall be noted clearly that the concerned bidder communicating this price to service provider has to solely ensure that the fax message is received by

**SIGNATURE OF THE TENDERER  
WITH SEAL AND ADDRESS**



the service provider in a readable/ legible form and also the Bidder should simultaneously check up with service provider about the clear receipt of the price faxed.

It shall also be clearly understood that the bidder shall be at liberty to send such fax communications of prices to be up loaded by the service provider only within the closure of Bid time and under no circumstance it shall be allowed beyond the closure of Bid time /reverse auction. It shall also be noted that the service provider should be given a reasonable required time by the bidders, to upload such prices online and if such required time is not available at the disposal of the Service provider at the time of receipt of the fax message from the bidders, the service provider will not be uploading the prices and either BHEL or the service provider are not responsible for this unforeseen circumstances. In order to ward-off such contingent situation bidders are requested to make all the necessary arrangements/ alternatives whatever required so that they are able to circumvent such situation and still be able to participate in the reverse auction successfully. Failure of power or loss of connectivity at the premises of bidders during the Reverse auction cannot be the cause for not participating in the reverse auction. On account of this, the time for the auction cannot be extended and neither BHEL nor M/s. {Service provider} is responsible for such eventualities.

- 13.** Proxy bids: Proxy bidding feature is a pro-bidder feature to safe guard the bidder" s interest of any internet failure or to avoid last minute rush. The proxy feature allows bidders to place an automated bid in the system directly in an auction and bid without having to enter a new amount each time a competing bidder submits a new offer. The bid amount that a bidder enters is the minimum that the bidder is willing to offer. Here the software bids on behalf of the bidder. This obviates the need for the bidder participating in the bidding process until the proxy bid amount is decrementally reached by other bidders. When proxy bid amount is reached, the bidder (who has submitted the proxy bid) has an option to start participating in the bidding process.

The proxy amount is the minimum amount that the bidder is willing to offer. During the course of bidding, the bidder cannot delete or change the amount of a proxy bid.

Bids are submitted in decrements (decreasing bid amounts). The application automates proxy bidding by processing proxy bids automatically, according to the decrement that the auction originator originally established when creating the auction, submitting offers to the next bid decrement each time a competing bidder bids, regardless of the fact whether the competing bids are submitted as proxy or standard bids. However, it may please be noted that if a manual bid and proxy bid are submitted at the same instant manual bid will be recognized as the L1 at that instant.

In case of more than one proxy bid, the system shall bid till it crosses the threshold value of „each lowest proxy bid" and thereafter allow the competition to decide the final L1 price.

Proxy bids are fed into the system directly by the respective bidders. As such this information is privy only to the respective bidder(s).

- 14.** Bidders are advised to get fully trained and clear all their doubts such as refreshing of Screen, quantity being auctioned, tender value being auctioned etc.
- 15.** M/s. {Service provider}, shall arrange to demonstrate/ train the bidder or bidder" s nominated person(s), without any cost to bidders. M/s. {Service provider}, shall also explain the bidders, all the rules related to the Reverse Auction/ Business Rules Document to be adopted along with bid manual. Bidders are required to give their compliance on it before start of bid process.

**SIGNATURE OF THE TENDERER  
WITH SEAL AND ADDRESS**

16. Successful bidder shall be required to submit the final prices, quoted during the Online Reverse Auction in **Annexure - III** after the completion of auction to M/s. Service provider besides BHEL, duly signed and stamped as token of acceptance without any new condition other than those already agreed to before start of auction.
17. Any variation between the final bid value and that in the confirmatory signed price breakup document will be considered as tampering the tender process and will invite action by BHEL as per extant guidelines in vogue.
18. Bidders bid will be taken as an offer to execute the work as per tender no BAP: M&S: TE: ELE: 14: 024: DT: 22.11.2014. Bids once made by the bidder, cannot be cancelled/ withdrawn and bidder shall be bound to execute the work as mentioned above at bidder's final bid price. Should bidder back out and not execute the contract as per the rates quoted, BHEL shall take action as per extant guidelines in vogue.
19. Bidders shall be assigned a Unique User Name & Password by BHEL or M/s. {Service provider}. Bidders are advised to change the Password and edit the information in the Registration Page after the receipt of initial Password from BHEL/ M/s. {Service provider} to ensure confidentiality. All bids made from the Login ID given to the bidders will be deemed to have been made by the bidders/ bidders' company.
20. Bidders shall be able to view the following on their screen along with the necessary fields during Online Reverse Auction:
  - a. Leading (Running Lowest) Bid in the Auction (only total price of package)
  - b. Bid Placed by the bidder
  - c. Start Price
  - d. Decrement value
21. After receipt of the system report from the Service Provider after completion of the Online Reverse Auction, BHEL will decide upon the winner. BHEL's decision on award of contract shall be final and binding on all the Bidders.
22. BHEL reserves the right to cancel the Reverse Auction process/ tender at any time, before ordering, without assigning any reason.
23. BHEL shall not have any liability to bidders for any interruption or delay in access to the site irrespective of the cause. In such cases, the decision of BHEL shall be binding on the bidders.
24. Other terms and conditions shall be as per bidder's techno-commercial offers and other correspondences, if any, till date.
25. Bidders are required to submit their acceptance to the terms/ conditions/ modalities before participating in the Reverse Auction in the process compliance Form as per **Annexure-II**.
26. BHEL can decide to extend, reschedule or cancel any Auction with prior intimation to all bidders.
27. If there is any clash between this business document and the FAQ available, if any, in the web site of M/s. {Service provider} the terms& conditions given in this business document will supercede the information contained in the FAQs. Any changes made by BHEL/ service provider (due to unforeseen contingencies) after the first posting shall be deemed to have been accepted if the bidder continues to access the portal after that time.

**SIGNATURE OF THE TENDERER  
WITH SEAL AND ADDRESS**

**ANNEXURE- I**

**The List of Items to be procured along with the Quantities and the Auction Start Time & Close Time is as follows:**

**ITEM DESCRIPTION: Electrical Petty works at BHEL, Ranipet**

1. For the following requirements to true line and level as directed by the Engineer-in-charge.

<b>Sl. No</b>	<b>SIZE</b>	<b>QUANTITY</b>	<b>OPENING PRICE (Rs.)</b>	<b>BID DECREMENT (Rs.)</b>	<b>AUCTION TIME</b>
1	As per BOQ	1 lot	<b>Shall get displayed on the site during the start of the auction.</b>	Will be informed later	Will be informed later

**SIGNATURE OF THE TENDERER  
WITH SEAL AND ADDRESS**

**Annexure – II**

**Process Compliance Form (Sample)**

(The bidders are required to print this on their company's letterhead and sign, stamp before faxing)

**To**

**- M/s. {Service provider**

**- Postal address}**

Sub: Agreement to the Process related Terms and Conditions

Dear Sir,

This has reference to the Terms & Conditions for the Reverse Auction mentioned in the tender document for Electrical petty works at **BHEL, Ranipet** against BHEL tender Notice no: **BAP: M&S: TE: ELE: 024: DT: 22.11.2014**. This letter is to confirm that:

1) The undersigned is authorized official/ representative of the company to participate in RA and to sign the related documents.

2) We have studied the Reverse Auction Terms & Conditions and the Business rules governing the Reverse Auction as mentioned in your letter and confirm our agreement to them.

3) We also confirm that we have taken the training on the auction tool and have understood the functionality of the same thoroughly.

4) We also confirm that, in case we become L1 bidder, we will email/ fax the price confirmation & break up of our quoted price as per template Excel working sheets issued by M/s BHEL M/s. {Service provider.

5) We confirm that **rates are valid till 90 days from the date of completion of Reverse Auction**

We, hereby confirm that we will honor the Bids placed by us during the auction process.

With regards

Signature with company seal

Name –

Company / Organization

Designation within Company / Organization

Address of Company / Organization

- Sign this document and Fax it to M/s {Service provider} at {.....} prior to start of the Event.

- Attach a signed copy of the tender document along with the Agreement Form/ Process Compliance form and send to M/s. {Service provider}

**SIGNATURE OF THE TENDERER  
WITH SEAL AND ADDRESS**

**Annexure – III**

**RA price confirmation and breakup (Sample)**

**To**

**M/s. Service provider**

**Postal address**

**CC: M/s BHEL**

**{Unit-**

**Address-}**

**Sub: Final price quoted during Reverse Auction and price breakup**

Dear Sir,

We confirm that we have quoted against the Tender notice no **BAP: M&S: TE: ELE: 14: 024: DT: 22.11.2014** as detailed below

As our final prices during the Reverse Auction conducted **on xx.xx.2014**.

Thanking you and looking forward to the valuable order from BHEL.

Yours sincerely,

,

**For** \_\_\_\_\_

**Name:**

**Company:**

**Date:**

**Seal:**

**SIGNATURE OF THE TENDERER  
WITH SEAL AND ADDRESS**

## **GENERAL INSTRUCTIONS TO BIDDRES**

1. Sealed Tenders for the work mentioned in the Schedule are invited from Contractors experienced in works of similar kind and magnitude.

2. Tenders must be submitted **in sealed covers** and should be addressed to

**Deputy General Manager  
M&S Department,  
Bharat Heavy Electricals Limited,  
RANIPET – 632 406.**

**The Name, Address of the Bidder and the name of work shall be clearly mentioned on the cover.**

3. Tenders will be received up to 14.30 hrs. on 18.12.2014 in the prescribed form and will be opened on 18.12.2014 at 14.30 hrs onwards at M&S Office Conference Hall in the presence of such of those Bidders or their agents who may choose to attend.

4. Bidder should sign and seal each and every page of the tender document including the drawings/annexure attached thereto before submitting the tender.

5. Tenders not submitted in the prescribed forms are liable for rejection.

6. In quoting the rates, the Bidders are advised to take into account all factors including any fluctuations in the market rates etc. No claim will be entertained on this account after acceptance of the tender or during the currency of the contract.

7. GENERAL CONDITIONS OF CONTRACT FOR WORKS, GENERAL INSTRUCTIONS TO BIDDERS, drawings, specifications and other documents also form part of the agreement to be entered into.

8. In the event of tender being submitted by a firm, the tender must be signed separately and legibly by each partner or member of the firm or in their absence, by the person holding the Power of Attorney on behalf of the firm concerned. In the latter case, a copy of the Power of Attorney duly attested by a Gazette Officer must accompany the tender.

9. The Bharat Heavy Electricals Limited, reserves the right to reject any or all the tenders received or accept any tender or part thereof without assigning any reason there for. In case of acceptance of a part of tender, time for completion may also be reduced to the extent considered appropriate by the accepting authority.

10. Unit rates should be quoted in figures as well as in words with reference to each item and for all the items shown in the attached schedule.

11. Rates quoted shall include all royalties, terminal taxes, octrai, duties, central and provincial excise tax, sales tax / VAT and other taxes levied under the State or Central Government Rules excluding applicable service tax for this work.

**SIGNATURE OF THE TENDERER  
WITH SEAL AND ADDRESS**

12. **Service Tax:**

1. Approximate value of free materials supplied by BHEL is Rs 62.50 lakhs.
2. The Bidder shall not include Service Tax in their quoted rates; but the bidder has to separately indicate the Service Tax amount and workings thereof in the Price bid format.
3. Bidders have to quote full Service Tax payable in the Price format included in the Bid document. Out of Full Service Tax amount indicated by the Bidder, 50% of the same shall be considered for evaluation of offers in the case of Bidders being an Individual, Sole Proprietary ship firm, Hindu Undivided Family or Partnership firm whether registered or not, including Association of Persons. For Other Bidders full Service Tax quoted shall be considered for evaluation.
4. In such cases of successful Bidder being an Individual, Sole Proprietary ship firm, Hindu Undivided Family or Partnership firm whether registered or not, including Association of Persons, 50% Service Tax amount quoted in the Price Bid format will be considered for reimbursement against valid documentary evidence. For others Service Tax quoted in the Price Bid will be considered for reimbursement against valid documentary evidence.
5. In such cases of Bidders being an Individual, Sole Proprietary ship firm, Hindu Undivided Family or Partnership firm whether registered or not, including Association of Persons, Service Tax payable by BHEL as receiver of Works contract Service i.e. 50% of the Service Tax payable for Works contracts service on composition basis on quoted price and the value of Free issue materials by BHEL @ 4.326% presently ( i.e. 70 % ) , shall be added to arrive at the total cost to BHEL for each bidder for the purpose of evaluation of Bids.

13. The quoted rates shall also include expenditures towards complying statutory payments like Provident fund, ESI payments, bonus etc for the labourer & staff deployed in the work.
14. The contractor will have to submit the Service Tax Registration certificate to BHEL and claim the Service Tax from BHEL by submitting Tax invoice as per Rules & Regulations of Service Tax and the documentary evidence will have to be submitted along with the next bill. If for any reason, the contractor has to pay penalty, interest on service tax, the contractor has to bear such additional payment. BHEL will pay only the service tax at actual. **The Bharat Heavy Electricals Limited will not entertain any claim in this regard.**

15. **PAYMENT TERMS :**

**Monthly post payment based on bills raised as per actual work done and as per the scope of work after certification of Engineer in-charge.**

16. If the bidder find discrepancies or omissions in the tender documents or should be in doubt as to their meaning, he should at once address the authority inviting the tender for clarification. Every endeavor is made to avoid any error which can materially affect the basis of the tender but the successful Bidder shall take up on himself to provide for the risk of any error which may be subsequently discovered and shall make no subsequent claim on account thereof.

**SIGNATURE OF THE TENDERER  
WITH SEAL AND ADDRESS**

17. Should a Bidder or a contractor has a relative or in the case of a firm or company of contractors any of its shareholders or share holder's relative, employed in Bharat Heavy Electricals Limited, the authority inviting tenders shall be informed of this fact at the time of submission of the tender failing which tender may be disqualified or if such fact subsequently come to light, the contract may be rescinded.
18. If the Bidder expires after submission of his tender, the Bharat Heavy Electricals Limited may be at the discretion of cancel such tender.
19. If a partner of a firm expires after submission of the tender or after the acceptance of the tender, Bharat Heavy Electricals Limited may cancel such tender at the discretion unless the firm retains his character.
20. The Bharat Heavy Electricals Limited will not bound by any Power of Attorney granted by the Bidder or changes in the composition of the firm made subsequent to the execution of the contract. They may, however, recognize such power of attorney and changes after obtaining proper legal advice, the cost of which will be chargeable to the contract concerned.
21. The contractor deliberately, gives wrong information in his tender or creates conditions favorable for the acceptance of his tender; Bharat Heavy Electricals Limited reserves the right to reject the tender at any stage.
22. Words imparting the singular number shall also deem to include the plural number and vice versa where the context so requires.
23. The General and Special Conditions of Contract are complimentary to each other and where they are in conflict, the Special Conditions shall prevail. In regard to matters not covered by the General or Special Conditions of Contract, those contained in the specifications approved by Bharat Heavy Electricals Limited shall apply.
24. Canvassing in any form in connection with the tender is strictly prohibited and the tenders submitted by the contractors who resort to canvassing will be liable for rejection.
25. All contractors will have to produce Income Tax clearance certificate from the Income Tax authorities concerned along with their tenders. Those contractors whose income is not taxable will be required to give an affidavit of their income on the prescribed form.
26. **The contractor should posse's necessary licenses, Permanent PF A/c No, and should take Insurance for his workers and produce them before commencement of work. The Contractor shall insure all his materials, tools, tackles etc. and also for third party.**

27. **COMPLIANCE TO REGULATIONS AND BY-LAWS**

The Contractor shall conform to the provisions of any statute relating to the work and regulations and By-laws of any local authority. The Contractor shall be bound to give all notices required by statute regulations or By-Laws as aforesaid and to pay all fees and taxes payable to any authority in respect thereof.

**SIGNATURE OF THE TENDERER  
WITH SEAL AND ADDRESS**



a) **Minimum Wages for the workers engaged for this work:**

The Contractor shall remain liable for the payment of all wages or other moneys to his work-men or employees under the payment of Wages Act 1936, Employees Liability Act. 1938, Workmen's Compensation Act 1923 or any other Act or enactment, relating thereto and rules framed, there under from time to time.

**The current minimum wages for skilled worker is Rs 296.00 / day, semi skilled worker is Rs 289.00 / day and for un skilled worker it is Rs. 281.00 / day. The contractor shall ensure to pay wages not less than this minimum wage to the workers deployed by him in this work along with other statutory payments. Any increase in wages during the entire period of contract also to be paid by the contractor within the quoted rates.**

In addition to the above the contractor is liable to pay additional lump-sum monthly payment as below.

- Rs.3200/- for unskilled worker
- Rs.3700/- for semiskilled worker
- Rs.4100/- for skilled worker

b) 8.33% bonus (minimum) to be paid.

c) The contractor shall maintain the detailed list of employees engaged during the contract execution period.

d) The contractor shall also maintain attendance details of the employees and register of payment and a copy of the details shall be submitted to the authorized official every months along with the bill for verification.

e) As per employees PF and misc. provisions Act 1952, the employee's contribution payable at present is 12% of wages which shall be recovered by the Contractor from the wages of his workmen and the contractor should pay equal contribution in addition to any administrative charges in this behalf that may be decided from time to time. Remittance shall be made on time (i.e. on or before 15<sup>th</sup> of the following month).

f) All the contract workers shall be enrolled in ESI (Employees' State Insurance). The effective date will be first day of the latest commencement of running contract concerned. The date shall be entered in the 'Date of Appointment' column of the ESI Declaration Form. The workers who are already members of ESI need not be enrolled again.

g) The filled ESI declaration forms shall be submitted to the Executive (HR-CLX, REX). In the Declaration Form full address of the contractor shall be mentioned. Whenever a fresh and unregistered worker is engaged during the operation of contract, declaration form in respect of that workman which should be submitted to Human Resources Department within two days of such engagement.

h) ESI contributions (1.75% employee's contribution + 4.75% employer contribution of the total monthly wages) before 20<sup>th</sup> day of every following month. Prescribed challans are available at ESI local office, Ranipet (near Sipcot). Contractors who have got their own code number can remit the contributions on that number.

i) Along with the challan copy, the details of remittance shall be submitted to the Executive (HR-CLX, REX) in the ESI compliance form.

**SIGNATURE OF THE TENDERER  
WITH SEAL AND ADDRESS**

28. The contractor should deduct Provident Fund and ESI amount as per the provisions and amount so deducted along with the matching contribution of the contractor shall be remitted to the authorities concerned within the stipulated time. The statement of deduction along with the challans evidencing remittance shall be submitted to Officer-in-charge. If the evidences are not shown, further bills of the contractor will not be paid.

BHEL have the right to withhold the payment of his bills. Submission of statutory returns such as Half Yearly returns of ESI (Form 6), P.F. return (Form 12A), Form 5 and Form 10, Form 3A & Form 6A should be send to the concerned officers in time.

29. In case of any increase in wage rates on account of revision of minimum wages by Government of Tamil Nadu and any revision of rate of contribution in Provident Fund, ESI and Bonus percentages due to statutory amendments, the contractor is bound to pay the revised amount. In case the revision of minimum wages is made by Government of Tamil Nadu with retrospective dates, the contract is bound to pay such arrears arising out of such revision of minimum wages retrospectively, failing which BHEL as the principal employer will retain the amount from the contractor and pay to contract labourers working under him.

30. The workers' particulars such as Name, Age, Father's name, address etc., and their daily attendance have to be maintained by the contractor. The details of Provident Fund and ESI compliance have to be maintained by the contractor in the prescribed format/register.

31. As per the Contract (Regulation & Abolition) Act, 1970 & Allied Rules, the contractor employing 20 or more labourers is required to obtain license from the Inspector of Labour, Vellore. This license shall be amended and/or renewed whenever there is an increase in the workman employed by him or in the event of contract being extended or renewed. The contractor shall inform the License Number so obtained to the Human Resources Department.

32. The contractor shall maintain the following Registers and Records and make them available for inspection at any time. (The list is only for example, but not exhaustive).

- a) Muster Roll
- b) Register of Wages
- c) Register of Deductions
- d) Register of Overtime
- e) Register of Fine
- f) Register of Advance
- g) Wage slips
- h) Register of Accidents
- i) Register of Leave with Wages
- j) ESI Register in Form-7.

All registers are required to be maintained as above and shall be produced as and when Government Officials and Statutory Authorities to make inspection from time to time.

33. In case a contract labourer meets with an accident while on duty, the contractor shall immediately intimate the information to Safety Department, Contracting Agency and Human Resources Department and submit the Accident Report duly filled in all respect and send a copy to ESI local office, ESI Dispensary and Inspector of Factories (for major accidents) with in 24 hours of accident through Safety and Human Resources Departments. All assistance for the injured workman such as to taking him to ESI Dispensary for treatment must be rendered by the contractor.

**SIGNATURE OF THE TENDERER  
WITH SEAL AND ADDRESS**

34. Compliance of the above provisions does not absolve the obligation of contractor arising out of other statutory obligations.
35. Employment of child labour is strictly prohibited.
36. Contractor should employ only persons having sound health and not above the age of 58 years, and not below the age of 18 years.
37. Payment of Bonus: In respect of work done by the labour, the contractor has to pay to his labourers as laid down by the Payment of Bonus Act – 1965.
38. The Bidder should be present if called for negotiation both technical and commercial. In case, the Bidder's authorized person is attending the negotiation such person should have the authorization letter and he should be capable of taking spot decisions.
39. In case the Bidder is not interested in submitting your quotation, they should return all the tender papers with a covering letter stating that your regrets for not submitting your offer for this tender.
40. If required bidders may visit the site/working area and obtain all clarifications from Tender Issuing Officer regarding the nature of job before offering their quotation.
41. The bidder shall clearly indicate all the applicable Taxes in the Price Bid and also shall state clearly whether these taxes are inclusive or exclusive of the Basic rate quoted. If any tender does not indicate applicable taxes, BHEL will assume, price quoted is inclusive of all Taxes and Tender will be evaluated accordingly.
42. The contractor should submit a notarized copy of the following documents.
- i. Pan card.
  - ii. TN VAT registration certificate.
  - iii. Service tax registration certificate.
43. The contractor shall indicate all the applicable taxes in the offer and any claim after the issue of contract will not be entertained.
44. In case if any Taxes not applicable, like due to threshold limit etc. Same may be clearly indicated in the offer by the Bidder.
45. **Discrepancy in "words" & "Figures":**
- a) If, in the price structure quoted for the required goods/services/works, there is discrepancy between the unit price and the total price (which is obtained by multiplying the unit price by the quantity), the unit price shall prevail and the total price corrected accordingly, unless in the opinion of the purchaser there is an obvious misplacement of the decimal point in the unit price, in which case the total price as quoted shall govern and the unit price corrected accordingly.
  - b) If there is an error in a total corresponding to the addition or subtraction of subtotals, the subtotals shall prevail and the total shall be corrected; and
  - c) If there is a discrepancy between words and figures, the amount in words shall prevail, unless the amount expressed in words is related to an arithmetic error, in which case the amount in figures shall prevail subject of (a) and (b) above.
  - d) If there is such discrepancy in an offer, the same shall be conveyed to the bidder with target date up to which the bidder has to send his acceptance on the above lines and if the bidder does not agree to the decision of the purchaser, the bid is liable to be ignored.

**SIGNATURE OF THE TENDERER  
WITH SEAL AND ADDRESS**

46. **SET OFF Clause:**

BHEL shall have the right to recover any money due from the contractor from any money due to the contractor under this contract or any other contract or from the security deposit.

47. **Free Issue Materials:**

<b>ANNEXURE- A</b>			
<b>Name of work:</b> Electrical Petty Works.			
<b>Free materials supplied by BHEL while executing the contract.</b>			
<b>S. No</b>	<b>Material Description</b>	<b>Quantity</b>	<b>Unit</b>
1	Any core up to 35 sq.mm PVC AR/UN AR aluminum/copper cable	4000	Mtrs
2	Any core exceeds 35 sq.mm but not exceeds 95 sq.mm PVC armored/un armored aluminum/copper cable	3500	Mtrs
3	Any core exceeds 95 sq.mm but not exceeds 185 sq.mm PVC armored/un armored aluminum/copper cable	3000	Mtrs
4	Any core exceeds 185 sq.mm but not exceeds 400 sq.mm PVC armored/un armored aluminum/copper cable	1200	Mtrs
5	Fluorescent / CFL fitting and lamp	150	No's
6	1x400W / 2x400W / 250W /125W HPMV / HPSV / MH light fitting with lamp	450	No's
7	Ceiling fan	150	No's
7	Supply of resistance type / electronic type ceiling fan regulator	45	No's
8	MAIN PANEL all sizes and capacity	16	No's
9	DB and ICTPN all capacity	50	No's
10	Man cooler, starter and Exhaust fan	56	No's
11	ICTPN & LTPN	52	No's
12	DSL Insulator	25	No's
13	Spare components for all type of Light fitting	450	No's

\* The above quantity is only approximate and may vary to any extent. The quantity will be known only after execution work.

**SIGNATURE OF THE TENDERER  
WITH SEAL AND ADDRESS**

**CERIFICATE OF NO DEVIATION**

I / We ..... of M/s ..... Hereby certify that **there is no deviation** from the tender conditions either technical or commercial and I am /We are agreeing to all the terms and conditions mentioned in the Tender Specification.

Date:

**Signature of the Bidder**

**SIGNATURE OF THE TENDERER  
WITH SEAL AND ADDRESS**

## **DRAWINGS**

( Note: The attached drawings are for Tender Purpose only ; During actual execution, some changes may occur )

**( No of Pages - 3 )**

REFERENCE DRAWING No: BAP: M&S: EL: PLNG: 001-13

NOT TO SCALE

**METHOD OF PIPE EARTHING**

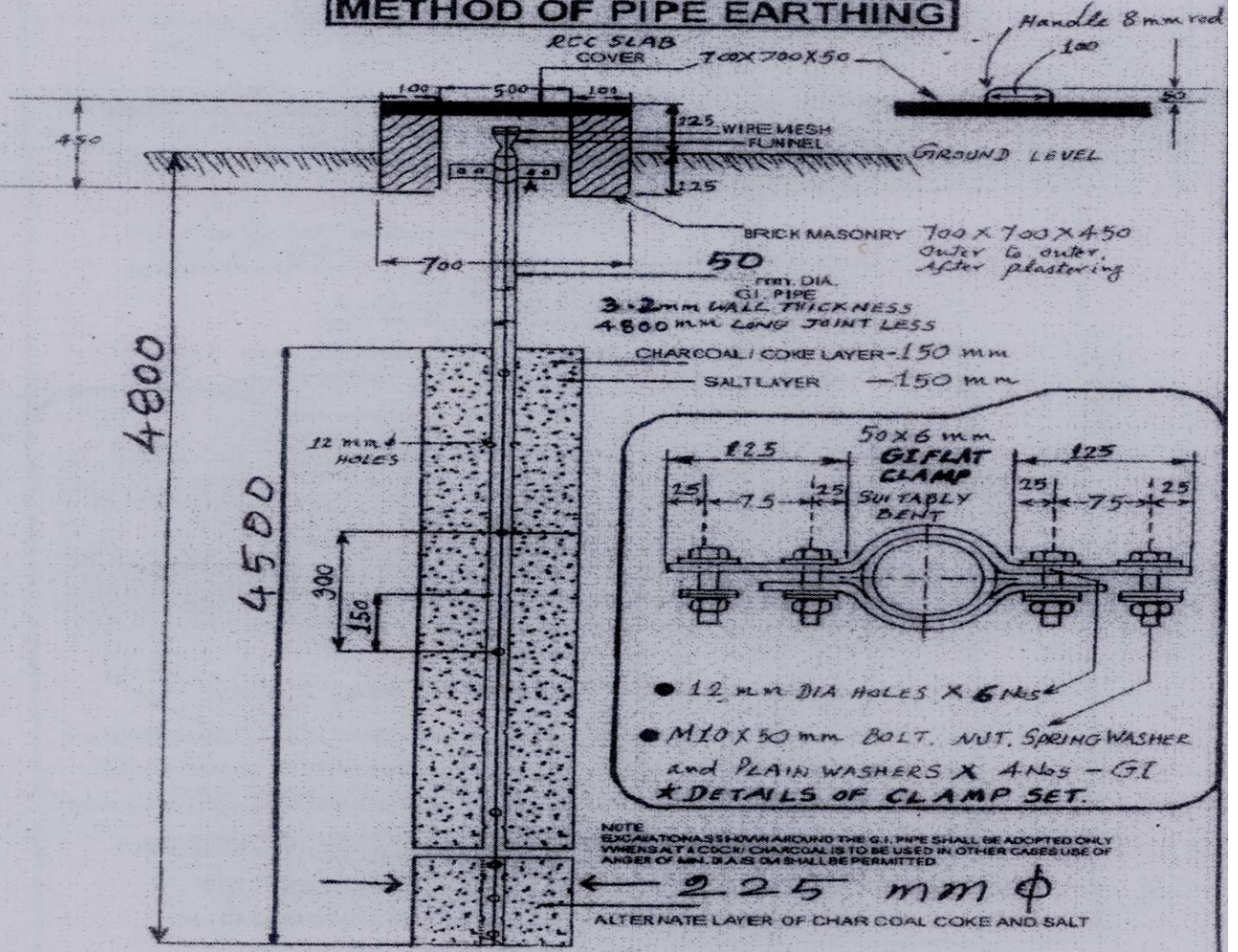

ALL DIMENSIONS ARE IN MM.

THE EARTH PIT RESISTANCE VALUE HAS TO BE MEASURED & THE RESISTANCE VALUE SHOULD BE NEATLY WRITTEN WITH PAINT ON THE PIT SLAB COVER.

*S. Muthukumar*  
 10/05/13

**S. MUTHUKUMAR**  
 Sr. Addl. Engineer - I  
 Electrical Services / M&S  
 BHEL / BAP / RANIPET - 632 406.

Approved

*P. Lakshmi Ramana*  
 10/05/13

**P. LAKSHMI RAMANA**  
 Senior Manager  
 M & S PLG & ES  
 BHEL / BAP / RANIPET - 632 406.

SIGNATURE OF THE TENDERER  
 WITH SEAL AND ADDRESS

MS Tubular Pole Drawing  
 As per IS 2713 [Part I to III] 1980  
 Drg No: ES:MS:1

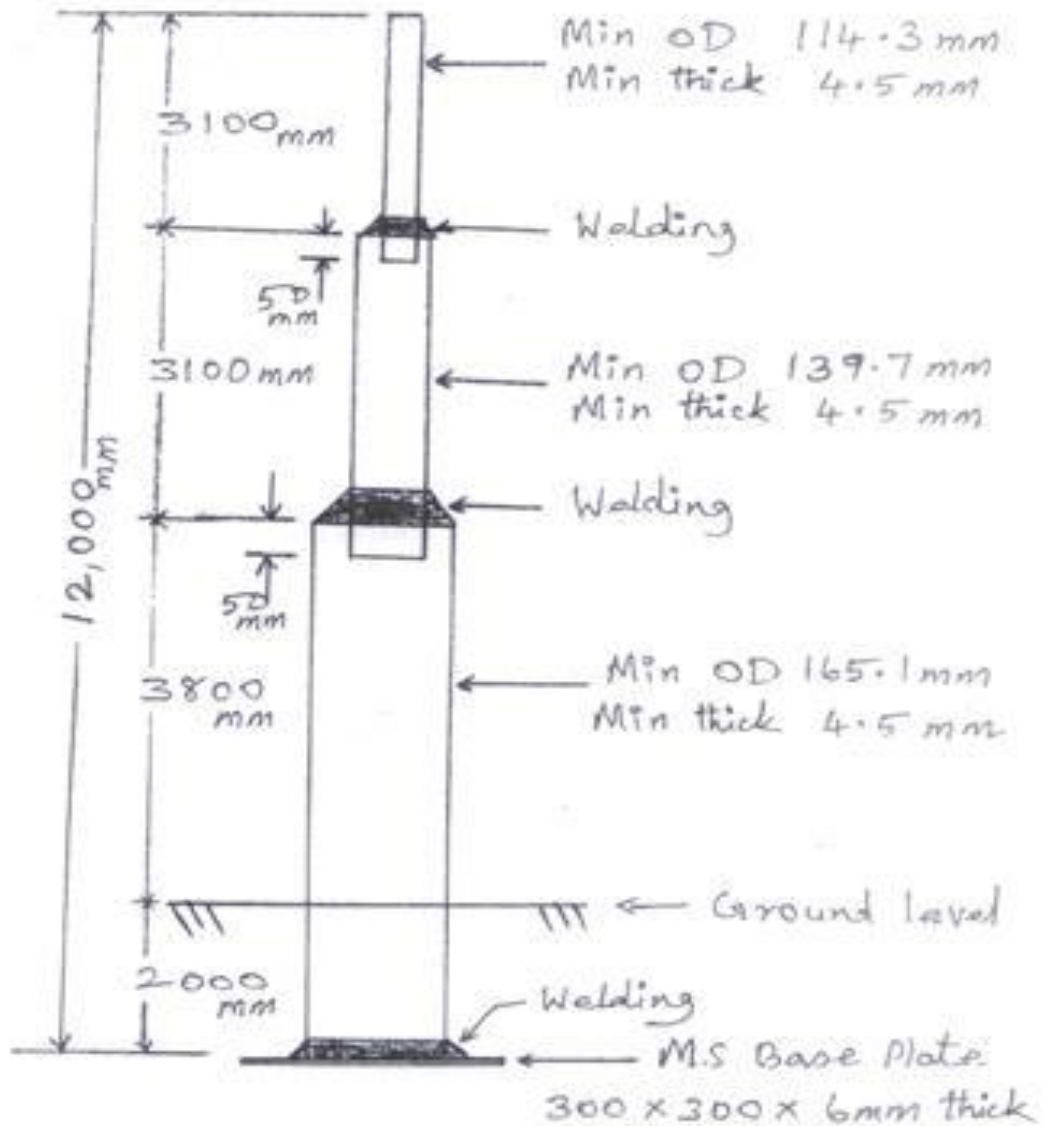

S. Muthukumar  
 Sr. Addl. Engineer - I  
 Electrical Services / M&S  
 BH&L / B&P / R&NP&T - 532 404

SIGNATURE OF THE TENDERER  
 WITH SEAL AND ADDRESS



# MS Pipe Bracket Drawing [To Fix Road Light fitting]

Dwg No: ES: M&S: 2A

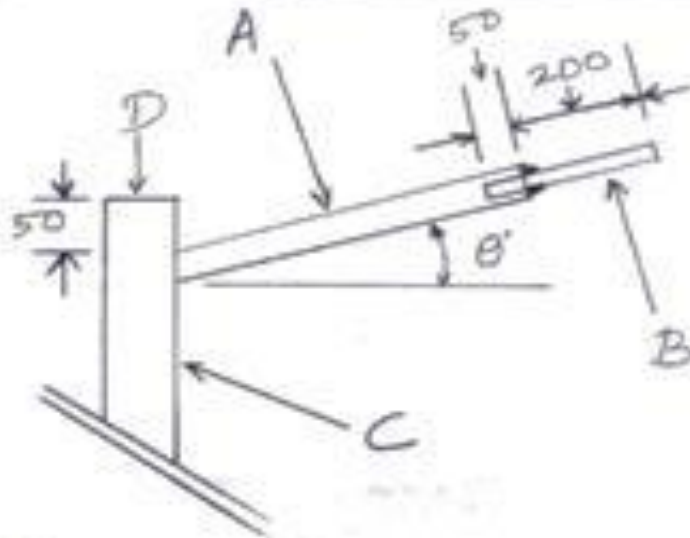

## Note:

1. A - MS pipe -  $76.9 \phi$ , 3.25 mm thick, 1000 mm length
2. B - MS pipe -  $50 \text{ mm } \phi$ , 3.25 mm thick, 200 mm length
3. C - Existing MS pole
4. D - MS pipe top to be closed by using 3mm thick (min) MS plate.
5.  $\theta$  - To be decided as per site conditions.

S. MURUGU  
S. MURUGU  
Sr. Asst. Engineer - I  
Electrical Services / S&S  
SHEL / SAP / RANPET - 402 404

SIGNATURE OF THE TENDERER  
WITH SEAL AND ADDRESS

## TECHNICAL INSTRUCTIONS

1. Fuse switches / switch fuses shall be of any one of the following make only Gec Alstom, L&T, GEC.
2. The DP switches, SP Switches, plugs and sockets shall be of standard make agreeable to Engineer in charge and should have been certified by ISI.
3. All materials supplied by the contractor should conform to the relevant IS / BS specification.
4. Single core, Single / Multi strand cables shall be of ISI approved make only, The armored cable shall be of ISI approved make only, Test Certificate of cables are to be submitted.
5. The wiring shall conform to IS 732 or any other relevant INDIAN STANDARD SPECIFICATION and INDIAN ELECTRICITY RULES. The installation shall also conform to the regulation for the electrical equipments of building laid down by Insurance Association of India (Fire Section).
6. In case of PVC / steel conduit wiring the switches, plug sockets, regulators and other controls should be mounted on metal boxes. These boxes as well as metal boxes used for street light controls should be fabricated as per IS: 5133 (part – 1 1969 ).
7. Final lay out, as well as Electrical drawings etc, should be submitted in advance for BHEL's approval.
8. Preparation of Electrical drawings, submitting the same to CEA / Local TNEB authorities to obtain EB Service connection etc, is under the contractor's scope.
9. The contractor should be present at the time of inspection of the installation by the Electrical Inspector. Any defect pointed out by the Electrical Inspector in the equipments (or) installations supplied by the contractor should be immediately rectified by the contractor free of cost.
10. The 'Completion Report' should be submitted as per Appendix-F of IS 732.

### 11. Recommended makes of different accessories:

S. NO	Name of accessory	Recommended make
01	Luminaries	Philips, GEC, Crompton, Bajaj, Havells
02	Ceiling fans	Orient, Crompton, Usha, Khaitan, Havells, Almonard
03	Switches / Sockets	Anchor, Kundan, Record with FAN/LIGHT marking
04	ICDP / ICTPN Switches	Bosma, Standard, GEM, GE, Raj
05	MCBs /	MDS Loadster, legrand, L&T, Hager, Siemens
06	Rotary switches	Salzer, Kaycee, Siemens, L&T
07	Metal Clad sockets & plugs	Sakthi Crown, B&C/Crompton, BCH
08	Single core cable	ISI approved make only
09	Armored cable	ISI approved make only

**SIGNATURE OF THE TENDERER  
WITH SEAL AND ADDRESS**

10	Fuse Distribution Boards	Bosma, Raj, GE, GEM, Standard
11	Exhaust fans	Orient, Crompton, Usha, Khaitan, Havells, Almonard
12	Combination Fuse Switches	GEC Alstom make

**12a) IF CABLE / CABLES HAVE TO BE LAID IN GROUND THE FOLLOWING SPECIFICATIONS SHOULD BE FOLLOWED.**

**For LOW TENSION cable SINGLE run**

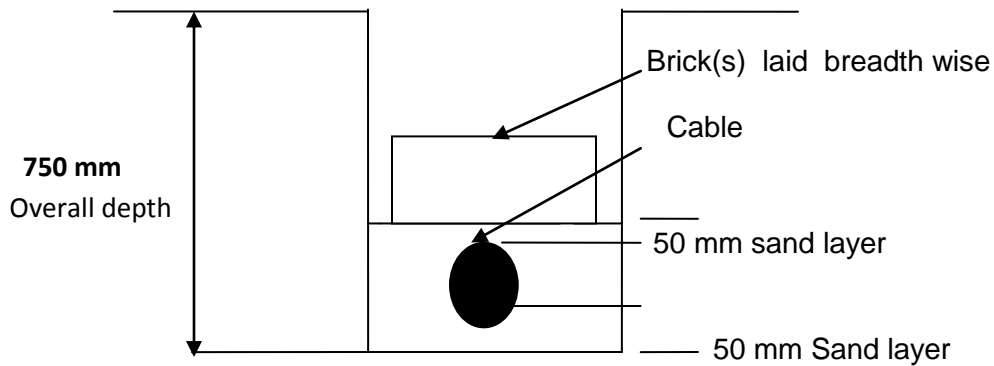

**For ONE run of cable :** The trench should be excavated to a depth, such that the cable will be laid at a minimum depth of 750 mm as shown above. Spread 50 mm deep layer of sand below the cable in trench, after laid the cable, also spread 50 mm deep layer of sand above the cable. Lay good quality bricks breadth wise only and cover the sand layer all along the cable / trench. Then complete the earth filling. The bricks shall be of good quality with size 100 mm x 75 mm x 225 mm.

**12b) If MORE than ONE cable:**

For LOW TENSION cables DOUBLE run (or) more the cables shall be laid as shown below:

The cables should be laid in horizontal plane. The trench should be excavated to a depth and breadth, such that the cables will be laid at a minimum depth of 750 mm in horizontal plane as shown above. Spread 50 mm deep layer of sand below the cables. Lay the cables in horizontal plane & place **good quality bricks** in between them **length wise continuously all along the cable / trench**. Further sand filling to be done for 50 mm over the cables.

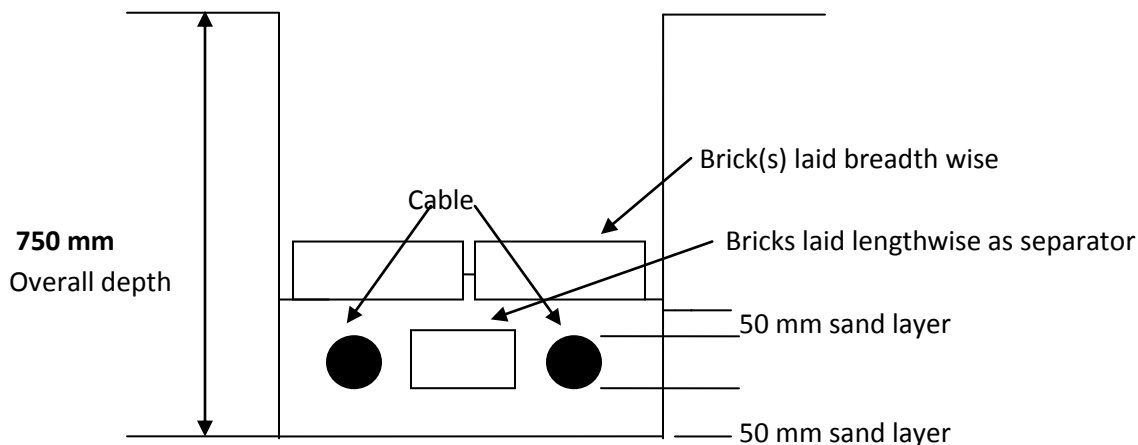

**SIGNATURE OF THE TENDERER  
WITH SEAL AND ADDRESS**

Lay good quality bricks breadth wise only and cover the sand layer all along the cable / trench. Then complete the earth filling. The bricks shall be of good quality with size 100 mm x 75 mm x 225 mm.

**13a)** For HIGH TENSION / 11 KV cable the trench should be excavated to a depth, such that the cable will be laid at minimum depth of 900 mm. Spread 50 mm deep layer of sand below the cable in trench. After laid the cable, lay good quality bricks length wise and vertically sideways to make box like arrangement covering both sides of the cable as shown below. Spread 50 mm deep layer of sand above the cable. Lay good quality bricks breadth wise only and cover the sand and brick layer all along the cable / trench. Then complete the earth filling. The bricks shall be of good quality with size 100 mm x 75 mm x 225 mm.

**For HIGH TENSION cable SINGLE run**

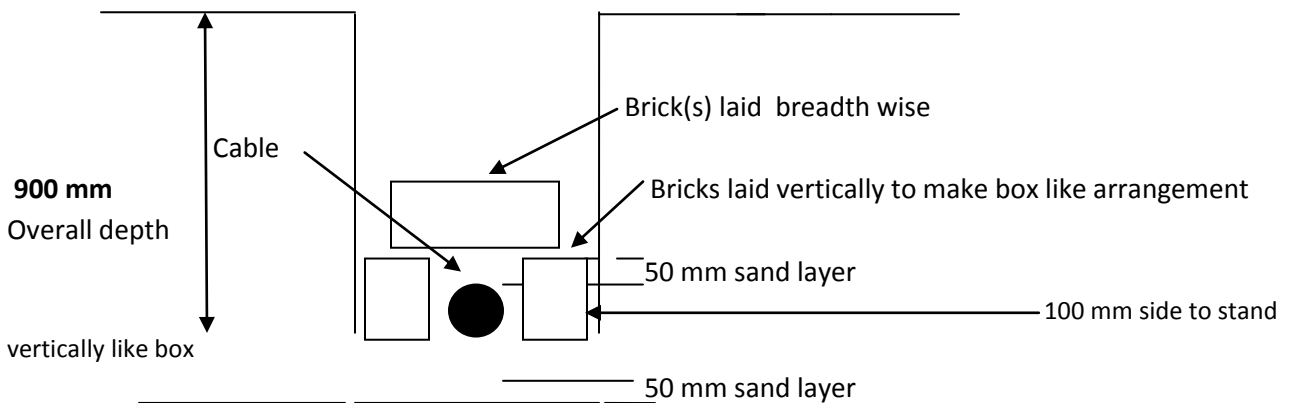

**13b) For HIGH TENSION cables DOUBLE run (or) more the cables shall be laid as shown below:**

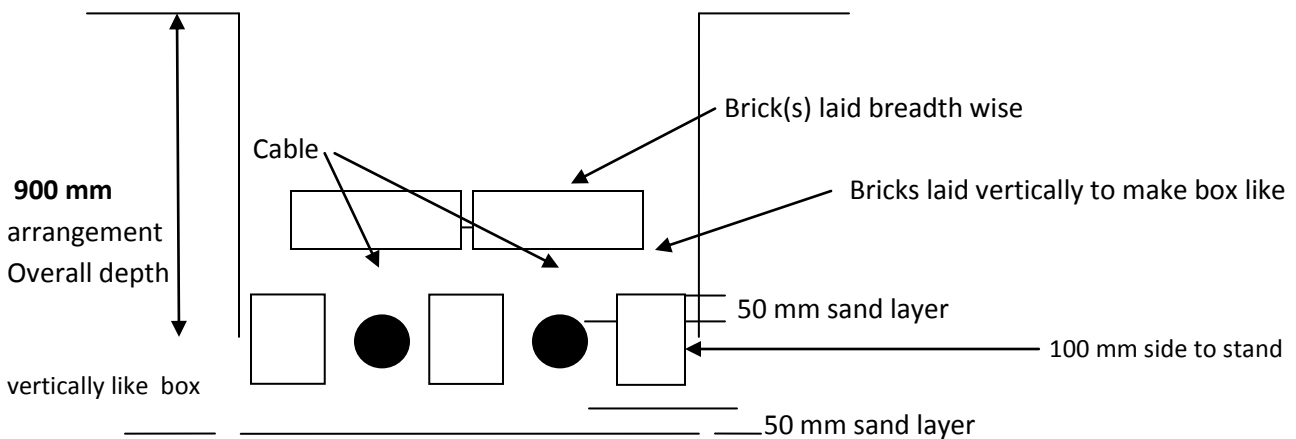

**SIGNATURE OF THE TENDERER  
WITH SEAL AND ADDRESS**

- 14) In case where cables have to be taken across the road, the pipes have to be laid across the road & the pipes will be supplied by BHEL. However if pipes are already available across the road, the cables have to be taken through that available pipes.

Cable 'Route Indicator' / 'Joint indicator' should be provided once in 20 Metre.

Cable 'Route Indicator' / 'Joint indicator' has to be supplied by the contractor.

- 15) In case of cable laying in open trench / wall / column, the cable has to be taken with proper clamping in cable trench / wall / column. The clamps are to be supplied by the contractor.

End termination of the cable is inclusive of supply and using of Pin / Eye type, Aluminum/Copper sockets, Glands, MS adopter boxes, Earthing of Glands & adopter boxes with 8 SWG (or) 7/20 GI wire.

- 16) In case of open trench / wall / column, cables have to be taken with proper clamping either in cable racks / wall / column. The clamps have to be supplied by the contractor.

End Termination for the cable include supply and using solerless crimping type tinned copper lugs, glands and if necessary cable adaptor boxes etc. and earthing the glands and adaptor boxes with 8 SWG/7/20 GI wire.

- 17) For all sheet metal fabrication, pre-treatment of all metals with acid and rust preventing chemical has to be carried out and two coats of red oxide and one coat of stove enameling paint has to be applied by spray painting.

- 18) The Contractor is required to cover their employee / labourers against any risk.

- 19) **PANELS:**

Cubicle / Industrial Type switch boards should be manufactured by any of the reputed manufacturer, if the make of the switch board is not specifically mentioned in the detailed specification of the board who have sufficient experience in manufacture of electrical switch boards. The switch board has to be approved by BHEL before dispatch to work spot.

All sheet steel used in the manufacture of Main Panel boards should not be less than 2 mm thick Ms sheet metal. The Main Panel board has to be approved by BHEL before dispatch to the work spot.

For all sheet metal fabrication, pre treatment of all metal with acid and rust preventing chemicals has to be carried. Two coats of red oxide and one coat of recommended color paint has to be applied by spray painting.

**SIGNATURE OF THE TENDERER  
WITH SEAL AND ADDRESS**

# **UN-PRICE BID**

## **(Page 54 of 71 )**

### **NOTE**

#### **SCHEDULE A:**

1. Contractor has to fill applicable service tax in Un-price bid of Schedule 'A' - SI. No 22.
2. This Un-Price bid should be submitted along with Techno-Commercial Bid.
3. The CONTRACT PERCENTAGE and amount should be quoted only in the PRICE – BID and to be submitted in a separate sealed cover along with the tender.

#### **SCHEDULE B:**

1. Contractor has to fill applicable service tax in Un-price bid of Schedule 'B'- SI. No 70.
2. This Un-Price bid should be submitted along with Techno-Commercial Bid.
3. The rate & amount should be quoted only in the PRICE – BID and to be submitted in a separate sealed cover along with the tender.

All the schedules (Schedule A & Schedule B) are covered both materials (either by contractor scope or BHEL free issue materials) and labour. Hence works contract service tax is applicable.

**SIGNATURE OF THE TENDERER  
WITH SEAL AND ADDRESS**

UN - PRICE BID					
<b>Name of the Work:</b> Electrical Petty Works.					
<b>Period of Contract:</b> Two Years					
SCHEDULE - A					
SL. NO	DESCRIPTION	UNIT	QUANTITY	Rate in Rs	Amount in Rs
<b>LAYING OF CABLE IN UNDERGROUND</b>					
1	Laying of one number PVC insulated and PVC sheathed / XLPE armored/unarmored (COPPER /ALUMINIUM) power cable of 1.1KV grade of following sizes direct in ground including excavation, sand cushioning , protective covering and refilling the trench etc as required. (cable will be supplied by BHEL free of cost at stores)				
	1.1 <b>Up to 35 sq.mm</b>	Metre	<b>1000.00</b>	195.00	195000
	1.2 <b>Above 35 sq.mm and Upto 95 sq.mm</b>	Metre	<b>750.00</b>	202.00	151500
	1.3 <b>Above 95 sq.mm and Upto 185 sq.mm</b>	Metre	<b>750.00</b>	210.00	157500
	1.4 <b>Above 185 sq.mm and Upto 400 sq.mm</b>	Metre	<b>500.00</b>	233.00	116500
<b>LAYING OF ADDITIONAL CABLE IN SL.NO:1</b>					
2	Laying of one number additional PVC insulated and PVC sheathed / XLPE armored/unarmored (COPPER /ALUMINIUM) power cable of 1.1KV grade of following sizes direct in ground in the same trench in one tier horizontal formation including excavation ,sand cushioning ,protective covering and refilling the trench etc as required. (cable will be supplied by BHEL free of cost at stores)				
	2.1 <b>Up to 35 sq.mm</b>	Metre	<b>100.00</b>	133.00	13300
	2.2 <b>Above 35 sq.mm and Upto 95 sq.mm</b>	Metre	<b>200.00</b>	141.00	28200
	2.3 <b>Above 95 sq.mm and Upto 185 sq.mm</b>	Metre	<b>500.00</b>	149.00	74500
	2.4 <b>Above 185 sq.mm and Upto 400 sq.mm</b>	Metre	<b>200.00</b>	171.00	34200
<b>LAYING OF CABLE ON WALL SURFACE</b>					
3	Laying and fixing of one number PVC insulated and PVC sheathed / XLPE armored/unarmored (COPPER /ALUMINIUM) power cable of 1.1KV grade of following sizes on surface as required. (cable will be supplied by BHEL free of cost at stores).				
	3.1 <b>Up to 35 sq.mm (Clamped with 1mm thick saddle)</b>	Metre	<b>750.00</b>	24.00	18000
	3.2 <b>Above 35sq.mm and Up to 95 sq.mm (Clamped with 25x3mm MS flat Clamp)</b>	Metre	<b>500.00</b>	70.00	35000
	3.3 <b>Above 95sq.mm and Up to 185 sq.mm (Clamped with 25/40x3mm MS flat Clamp)</b>	Metre	<b>200.00</b>	81.00	16200
	3.4 <b>Above 185sq.mm and Up to 400 sq.mm (Clamped with 40x3mm MS flat Clamp)</b>	Metre	<b>100.00</b>	115.00	11500

SIGNATURE OF THE TENDERER WITH SEAL ADDRESS

SL. NO	DESCRIPTION	UNIT	QUANTITY	Rate in Rs	Amount in Rs
<b>LAYING OF CABLE ON CABLE TRAY</b>					
4	Laying and fixing of one number PVC insulated and PVC sheathed / XLPE armored/unarmored (COPPER /ALUMINIUM) power cable of 1.1KV grade of following sizes on Cable Tray as required. (cable will be supplied by BHEL free of cost at stores).				
	4.1 <b>Up to 35 sq.mm (Clamped with 1mm thick saddle)</b>	Metre	<b>500.00</b>	20.00	10000
	4.2 <b>Above 35sq.mm and Up to 95 sq.mm (Clamped with 25x3mm MS flat Clamp)</b>	Metre	<b>250.00</b>	48.00	12000
	4.3 <b>Above 95sq.mm and Up to 185 sq.mm (Clamped with 25/40x3mm MS flat Clamp)</b>	Metre	<b>200.00</b>	59.00	11800
	4.4 <b>Above 185sq.mm and Up to 400 sq.mm (Clamped with 40x3mm MS flat Clamp)</b>	Metre	<b>100.00</b>	91.00	9100
<b>LAYING OF CABLE IN GROUND WITHOUT SAND AND PROTECTIVE COVERING</b>					
5	Laying of one number PVC insulated and PVC sheathed / XLPE armored/unarmored (COPPER /ALUMINIUM) power cable of 1.1KV grade of following size direct in ground including excavation and refilling the trench, but excluding sand cushioning and protective covering. (cable will be supplied by BHEL free of cost at stores)				
	5.1 <b>Upto 35 sq.mm</b>	Metre	<b>300.00</b>	<b>87.00</b>	26100
	5.2 <b>Above 35 sq.mm and Upto 95 sq.mm</b>	Metre	<b>500.00</b>	<b>95.00</b>	47500
	5.3 <b>Above 95 sq.mm and Upto 185 sq.mm</b>	Metre	<b>500.00</b>	<b>102.00</b>	51000
	5.4 <b>Above 185 sq.mm and Upto 400 sq.mm</b>	Metre	<b>100.00</b>	<b>125.00</b>	12500
<b>LAYING OF CABLE IN RCC/HUME/METAL PIPE</b>					
6	Laying of one number PVC insulated and PVC sheathed / XLPE armored/unarmored (COPPER /ALUMINIUM) power cable of 1.1KV grade of following sizes in the existing RCC/HUME/METAL PIPE (cable will be supplied by BHEL free of cost from stores).				
	6.1 <b>Up to 35 sq.mm</b>	Metre	<b>750.00</b>	<b>16.00</b>	12000
	6.2 <b>Above 35sq.mm and Up to 95 sq.mm</b>	Metre	<b>500.00</b>	<b>25.00</b>	12500
	6.3 <b>Above 95sq.mm and Up to 185 sq.mm</b>	Metre	<b>200.00</b>	<b>33.00</b>	6600
	6.4 <b>Above 185sq.mm and Up to 400 sq.mm</b>	Metre	<b>100.00</b>	<b>58.00</b>	5800
<b>LAYING OF CABLE ON OPEN DUCT</b>					
7	Laying of one number PVC insulated and PVC sheathed / XLPE armored/unarmored (COPPER /ALUMINIUM) power cable of 1.1KV grade of following sizes in the existing masonry open dut as required. (cable will be supplied by BHEL free of cost from stores).				
	7.1 <b>Up to 35 sq.mm</b>	Metre	<b>500.00</b>	<b>12.00</b>	6000
	7.2 <b>Above 35sq.mm and Up to 95 sq.mm</b>	Metre	<b>500.00</b>	<b>20.00</b>	10000

SIGNATURE OF THE TENDERER WITH SEAL ADDRESS



SL. NO	DESCRIPTION	UNIT	QUANTITY	Rate in Rs	Amount in Rs
7.3	Above 95sq.mm and Up to 185 sq.mm	Metre	200.00	27.00	5400
7.4	Above 185sq.mm and Up to 400 sq.mm	Metre	100.00	50.00	5000
<b>INSATALLATION &amp; TESTING</b>					
8	Installation,testing and commissioning of pre-wired Flourescent fitting / CFL fitting of all types, complete with all accessories and tube etc.directly on ceiling / wall, including connection with 1.5sq.mm FR PVC insulation,copper conductor, single core cable and earthing etc, as required. (fitting and lamp will be supplied by BHEL free of cost).	Each	20.00	91.00	1820
9	Installation,testing and commissioning of resistance type ceiling fan regulator, in existing switch box including connection with 1.5sq.mm FRLS PVC insulation,copper conductor, single core cable and earthing the regulator etc, as required. (Regulator will be supplied by BHEL free of cost).	Each	10.00	52.00	520
<b>SUPPLY AND FIXING</b>					
10	Supply and fixing danger notice plate of following sizes, made of mild steel, at least 2 mm thick, and enamelled white on both sides, and with description in single red colour on front side as required.				
10.1	For Medium Voltage 200 mm x 150 mm	Each	10.00	141.00	1410
10.2	For High Voltage 250 mm x 200 mm	Each	10.00	155.00	1550
11	Supply and fixing cable route marker with 10cm x 10cm x 5cm thick G.I plate with inscription there on, bolted / welded to 35mm x 35mm x 6mm angle iron,60cm long and fixing the same in ground as required.	Each	50.00	288.00	14400
12	Supply and fixing of following sizes of Medium class PVC conduit along with accessories in surface / recess including cutting the wall and making good the same in case of recessed conduit as required.				
12.1	20 mm	Metre	150.00	53.00	7950
12.2	32 mm	Metre	50.00	85.00	4250
	50 mm	Metre	50.00	144.00	7200
13	Supply and replacing the defective switch/socket and fixing a new switch / socket on the existing switch box and having equivalent quality of Make : Anchor , GM , Havells.				
13.1	5/6 amps switch.	Each	500.00	33.00	16500
13.2	15/16 amps switch.	Each	50.00	72.00	3600

SIGNATURE OF THE TENDERER WITH SEAL ADDRESS

SL. NO	DESCRIPTION	UNIT	QUANTITY	Rate in Rs	Amount in Rs	
13.3	5/6 amps socket outlet.	Each	500.00	41.00	20500	
13.4	6 pin 15/16 amps socket outlet.	Each	30.00	83.00	2490	
14	Supply and Wiring for circuit / submain wiring along earth wire with the following sizes of FRLS PVC insulated copper conductor single core cable in surface / wall with recessed <b>steel conduit</b> , as required.					
14.1	(2 x 1.5 sq.mm ) + (1 x 1.5 sq.mm Earth wire)	Metre	400.00	175.00	70000	
14.2	(2 x 2.5 sq.mm ) + (1 x 2.5 sq.mm Earth wire)	Metre	750.00	200.00	150000	
15	Supply and Wiring for circuit / submain wiring along earth wire with the following sizes of FRLS PVC insulated copper conductor single core cable in surface / wall with recessed 2mm thick <b>PVC conduit</b> , as required.					
15.1	(2 x 1.5 sq.mm ) + (1 x 1.5 sq.mm Earth wire)	Metre	2500.00	106.00	265000	
15.2	(2 x 2.5 sq.mm ) + (1 x 2.5 sq.mm Earth wire)	Metre	3000.00	131.00	393000	
16	<b>Value of Schedule - A</b>				<b>2054890</b>	
17	<b>CONTRACTOR'S TENDER PERCENTAGE</b>		Indicate %	Note	Please Tick <input type="checkbox"/>	Indicate Amount
				BELOW	<input type="checkbox"/> B1	(-)
			%	ABOVE	<input type="checkbox"/> B2	(+)
				AT PAR	<input type="checkbox"/> B3	(-) 0.00
18	Tender Percentage in Words					
19	Sub Total value of schedule 'A' as per SL . No (16 ± 17 )			Rs.	X	
20	Value of Free Issue Materilas ( APPROXIMATELY)			Rs.	35,00,000	
21	Total (Assessable Value) of Schedule 'A' including free issue Materials as per SL.No (19) + (20)			Rs.	X	
22	Service Tax (on works contract) _____% (Contractor has quote service tax)					
23	Total value of schedule 'A' as per SL. No (19) + (22)			Rs.	X	
<b>Note:</b>						
1. Contractor has to fill applicable service tax in Sl. No 22.						
2. This Un-Price bid should be submitted along with Techno-Commercial Bid.						
3. The rate & amount should be quoted only in the PRICE – BID and to be submitted in a separate sealed cover along with the tender.						

SIGNATURE OF THE TENDERER WITH SEAL ADDRESS

UN - PRICE BID						
Name of the Work: Electrical Petty Works.						
Period of Contract: Two Years						
SCHEDULE - B						
SL. NO		DESCRIPTION	UNIT	QUANTITY	Rate in Rs	Amount in Rs
<b>SUPPLY AND MAKING JOINTS</b>						
1		Supply and making straight through joints with cast resin compound including ferrules and other jointing materials for following size of PVC insulated and PVC sheathed / XLPE <b>aluminium</b> armored/unarmored conductor cable of 1.1KV grade as required.				
	1.1	<b>3 x 50 sq.mm</b>	Each	<b>5.00</b>		
	1.2	<b>3.5 x 50 sq.mm</b>	Each	<b>5.00</b>		
	1.3	<b>3.5 x 70 sq.mm</b>	Each	<b>5.00</b>		
	1.4	<b>3.5 x 95 sq.mm</b>	Each	<b>5.00</b>		
	1.5	<b>3.5 x 185 sq.mm</b>	Each	<b>10.00</b>		
	1.6	<b>3.5 x 300 sq.mm</b>	Each	<b>3.00</b>		
<b>INSTALLATION &amp; TESTING</b>						
2		Installation and testing of 1x400W / 2x400W / 250W /125W HPMV / HPSV / MH light fitting with lamp,of all type on the column / wall / post / tower / roof with down rod, supporting angle, necessary fixtures etc. (Supply of downrod and supporting angle will be contractor scope). (fitting and lamp will be supplied by BHEL free of cost) at stores.	Each	<b>150.00</b>		
3		Installation,testing and commissioning of ceiling fan and regulator including supply and wiring the down rods of standard length (up to 30 cm) with 1.5sq.mm FRLS PVC insulation, copper conductor, single core cable and earthing etc, as required. (Supply of downrod will be contractor scope) (fan will be supplied by BHEL free of cost) at stores.	Each	<b>60.00</b>		
4		Erection of 400/800Amps MAIN PANEL of following sizes a) Necessary MS channel of size 100mmx50mm shall be supplied and provided for the erection of MP atleast 1support for a length of 1 metre. b) The support channels shall be neatly fixed across the cable trench, by welding or grouting. c) The MS channels shall be thoroughly cleaned and painted with one coat of red-oxide and two coat of enamelled paint as required. (The main panel alone will be supplied by BHEL free of cost) ar stores.				
	4.1	2Metre length	Each	<b>1.00</b>		

SL. NO		DESCRIPTION	UNIT	QUANTITY	Rate in Rs	Amount in Rs
	4.2	3Metre length	Each	1.00		
	4.3	4Metre length	Each	1.00		
	4.4	5Metre length	Each	1.00		
5		Fixing of following ways 63A per way TPN HRC fuse distribution board with following rating of ICTPN as incomer with top and bottom entry MS cable adoptor box on suitable iron frame work or iron frame stand to be fixed on the concrete floor with necessary inter-connection,masonry work and etc as required. (Iron frame and adoptor will be contractor scope). (The DB and ICTPN will be supplied by BHEL free of cost) at stores.				
	5.1	4 way DB,100A ICTPN as incomer	Each	3.00		
	5.2	8 way DB,200A ICTPN as incomer	Each	3.00		
6		Fixing of following ways 32A per way TPN HRC fuse distribution board with following rating of ICTPN as incomer with top and bottom entry MS cable adoptor box on suitable iron frame work or iron frame stand to be fixed on the concrete floor with necessary inter-connection,masonry work and etc as required. (Iron frame and adoptor will be contractor scope), (The DB and ICTPN will be supplied by BHEL free of cost) at stores.				
	6.1	4 way DB, 63A ICTPN as incomer	Each	5.00		
	6.2	8 way DB, 100A ICTPN as incomer	Each	5.00		
	6.3	12 way DB, 200 ICTPN as incomer	Each	3.00		
7		Fixing of following ways 16A/20A per way TPN HRC fuse distribution board with following rating of ICTPN as incomer with top and bottom entry MS cable adoptor box on suitable iron frame work or iron frame stand to be fixed on the concrete floor with necessary inter-connection,masonry work and etc as required. (Iron frame and adoptor will be contractor scope), (The DB and ICTPN will be supplied by BHEL free of cost) at stores.				
	7.1	8 way DB, 63A ICTPN as incomer	Each	3.00		
	7.2	12 way DB, 100A ICTPN as incomer	Each	3.00		

SL. NO		DESCRIPTION	UNIT	QUANTITY	Rate in Rs	Amount in Rs
8		Fixing of 300 / 450 / 600mm Sweep, 3 Phase 415V Man cooler along with suitable DOL starter on iron frame work, with 3 pole 6 amps MCB, in 2mm thick MS box, the iron frame and MS box to be fixed on column / wall with necessary fixtures etc. (Man cooler and starter will be supplied by BHEL) at stores, (MS box and MCB will be contractor scope) .	Each	15.00		
9		Installation, testing and commisioning of Exhaust fans up to 510mm sweep single phase by making holes to suit on the wall, required masonary work to making good the damage, including connection as required. (Exhaust fan will be supplied by BHEL) at stores.	Each	10.00		
10		Fixing of following capacity ICTPN/LPTPN type disconnecter fuse switch unit on the existing cubicle panel board with MS cable entry adoptor box (top/bottom) with necessary fixtures etc, including drilling holes in cubicle panel, making connections, etc as required. (supply of Adaptor box is contractor scope). (ICTPN/LPTPN will be supplied by BHEL) at stores.				
	10.1	32 Amp TPN / FP	Each	5.00		
	10.2	63 Amp TPN / FP	Each	5.00		
	10.3	100 Amp TPN	Each	5.00		
	10.4	200 Amp TPN	Each	5.00		
	10.5	315/400 Amp TPN	Each	5.00		
11		Fixing following capacity ICTPN / LPTPN type disconnecter fuse switch unit on suitable iron frame work on floor/wall/column with (2 mm thick) MS cable entry adoptor box on (top and bottom) with necessary inter-connection,masonary work and etc as required. (supply of Adaptor box and iron frame will be contractor scope). (ICTPN/LPTPN will be supplied by BHEL) at stores.				
	11.1	32 Amp TP&N	Each	5.00		
	11.2	63 Amp TP&N	Each	10.00		
	11.3	100 Amp TP&N	Each	5.00		
	11.4	200 Amp TP&N	Each	5.00		
	11.5	315/400 Amp TPN	Each	2.00		

SL. NO	DESCRIPTION	UNIT	QUANTITY	Rate in Rs	Amount in Rs
12	Numbering of ceiling fan / exhaust fan / flourescent fittings as required. Make: nerolac, asian, tractor. (paint, brush will be contractor scope).	Each	50.00		
13	Supply and painting with one coat of red oxide as primer and two coats of synthetic enamel of selected colour on metal surfaces of Transformers/ DB / MP / Isolators / Street Light Pole / Fencing / Steel structures/ Angles / Bracing / Column etc. with Paint having equivalent quality of make:nerolac, asian, tractor.	sq ft	5000.00		
<b>SUPPLY AND FIXING</b>					
14	Supply and fixing of galvanized MS (2mm thick plate) cable tray of size 200mm width and 150mm height with cover on ground using jumber bolt.	Mtr	20		
15	Supply and fixing suitable clamps and necessary fixtures for existing PVC / STEEL (19mm/24mm/36mm)conduits on wall / surface / column.	Metre	50.00		
16	Supplying and fixing of metal box (2mm thick) with cover of following sizes (Nominal size) on surface / wall / recess with Phosphatized and powder painted, locking facility as required.				
16.1	100 mm x 100 mm x 60 mm deep	Each	30.00		
16.2	200 mm x 250 mm x 60 mm deep	Each	75.00		
16.3	200 mm x 150 mm x 100 mm deep	Each	20.00		
	250 mm x 300 mm x 60 mm deep	Each	25.00		
17	Supply and replacing / fixing of following rating of socket and switch on following size of metal box (nominal size) on surface / wall / column / recess with suitable size of phenolic laminated sheet cover in front including providing and fixing ,interconnections,painting etc as required.				
17.1	MS box of 150 mm x 75 mm x 60 mm deep, 5 / 6 Amps socket outlet and flushtype switch	No.	20.00		
17.2	MS box of 180 mm x 100 mm x 60 mm deep, 15 / 16 Amps socket outlet and flushtype switch	No.	75.00		

SL. NO	DESCRIPTION	UNIT	QUANTITY	Rate in Rs	Amount in Rs
18	Supplying and fixing following way, single pole and neutral, sheet steel, MCB distribution board, 240 volts, on surface / wall / column /recess, complete with tinned copper busbar, neutral busbar, earth bar, din bar, detachable gland plate, interconnections, phosphatized and powder painted including earthing, as required.(with out MCB) and having equivalent quality of make:GE,MDS,Siemens, legrand,Havells, Kundan,Fybros.				
	4 way ,single door	Each	5.00		
	18.1 8 way ,single door	Each	5.00		
	18.2 12 way ,single door	Each	5.00		
19	Supplying and fixing 4way, single door, horizontal type three pole and neutral, sheet steel, MCB distribution board, 415 volts, on surface / wall /recess, complete with tinned copper busbar, neutral busbar, earth bar, din bar, detachable gland plate, interconnections, phosphatized and powder painted including earthing, as required.(with out MCB) and having equivalent quality of MCB make:GE, MDS, Siemens, legrand, Havells, Kundan, Fybros.	Each	5.00		
20	Supplying and fixing 5 Amps to 32 Amps rating, 240 / 415 volts, 'C' Curve, MCB suitable for inductive load of following poles in the existing MCB DB, complete with connections, testing and commissioning etc, as required and having equivalent quality of MCB make:GE,MDS,Siemens,legrand,Havells,Kundan, Fybros.				
	20.1 Single pole	Each	50.00		
	20.2 Double pole	Each	25.00		
	20.3 Triple pole	Each	10.00		
	20.4 Triple pole & neutral	Each	10.00		
21	Supplying and fixing following rating double pole MCB, 240 volts, in the existing MCB DB, complete with connections, testing and commissioning etc, as required and having equivalent quality of MCB make:GE,MDS,Siemens,legrand,Havells,Kundan, Fybros.				
	21.1 40 amps	Each	5.00		
	21.2 63 amps	Each	5.00		
22	Supplying and fixing following rating four pole MCB, 415 volts, in the existing MCB DB, complete with connections, testing and commissioning etc, as required and having equivalent quality of MCB make:GE,MDS,Siemens,legrand,Havells,Kundan, Fybros.				
	22.1 40 amps	Each	5.00		
	22.2 63 amps	Each	5.00		

SL. NO	DESCRIPTION	UNIT	QUANTITY	Rate in Rs	Amount in Rs
23	Supply and fixing of following rating of MCB with connection and earthing and necessary fixtures as required and having equivalent quality of MCB. MAKE:GE,MDS,Siemens,legrand,Havells,Kundan, Fybros.				
	23.1 63Amps TPN MCB On the existing distribution board/MS box	Each	5.00		
	23.2 32Amps TPN MCB On the existing distribution board/MS box	Each	5.00		
	23.3 32Amps DP MCB On the existing distribution board/MS box	Each	5.00		
	23.4 25Amps TPN MCB On the existing distribution board/MS box	Each	5.00		
	23.5 25Amps DP MCB On the existing distribution board/MS box	Each	5.00		
24	Supplying and fixing of metal clad socket of Best & Crompton / Sakthi Crown make with plug top along with suitable rating MCB as given, in 2mm thick MS box, on surface / wall / recess / Column / ground, with cover for the socket outlet and complete with connections, testing and commissioning etc, as required and having equivalent quality of MCB. make:GE, MDS, Siemens, legrand, Havells, Kundan, Fybros.				
	24.1 1phase, 3 pin, 10 Amps socket & plug top and 10 Amps DP MCB.	Each	20.00		
	24.2 1phase, 3 pin, 20 Amps socket & plug top and 20 Amps DP MCB.	Each	25.00		
	24.3 3phase, 4 pin, 20 Amps socket & plug top and 20 Amps TP MCB.	Each	25.00		
	24.4 3phase, 4 pin, 30 Amps socket & plug top and 30 Amps TP MCB.	Each	20.00		
25	Supplying and fixing three phase 30 Amps ,415 volt, 5-pin TPN industrial type socket outlet with 4pole and earth metal enclosed plug top along with 30Amps MCB, c curve TPMCB in sheet steel enclosure or in recess, with chinel metal cover, for the socket outlet and complete with connections, testing and commissioning etc, as required and having equivalent quality of MCB make:GE,MDS,Siemens,legrand,Havells,Kundan, Fybros.	Each	25.00		
26	Supply & fixing steel wire mesh for three phase column mounted / tabular / pedestal mancoolers with necessary binding wires etc.,	Each	20.00		
	Supply and laying of following earth strip / wire / bus on surface / wall / recess connections as required.				
	27.1 50x6mm GI flat for earthing.	Metre	200.00		
	27.2 25x6mm GI flat for earthing.	Metre	500.00		



SL. NO		DESCRIPTION	UNIT	QUANTITY	Rate in Rs	Amount in Rs
27	27.3	25mm x 5mm G.I earth strip	Metre	50.00		
	27.4	25x3mm GI flat for earthing.	Metre	500.00		
	27.5	8 SWG GI wire	Metre	600.00		
	27.6	14 SWG G.I wire	Metre	50.00		
	27.7	8 SWG copper wire	Metre	50.00		
	27.8	14 SWG Bare Copper wire	Metre	300.00		
	27.9	25mm x 6 mm copper flat	Metre	20.00		
	27.10	50mm x 6 mm copper flat	Metre	20.00		
28		Supply and fixing of weather proof (2mm thick) MS box of size 200mm height x 240mm length x 150mm depth with one coat of red oxide and 2 coat of alu. paint for street light with 1 No of 15A fuse carrier and 6 way 15A connector.	Each	75.00		
29		Supply and fixing calling bell / buzzer suitable for single phase, 230v, complete as required.	Each	5.00		
30		Supply, Installation, testing and commisioning of following sweep size Exhaust fan, single phase,1420 rpm fan with suitable mounting rings, brackets and resilient rubber cushions and with necessary fixtures and with self closing louvers, by making holes to suit on the wall, making good the damage, including connection as required and having equivalent quality. Make: Almonard, Havells, Crompton, Orient, Khaithan.				
	30.1	450mm sweep	Each	20.00		
	30.2	300mm sweep	Each	10.00		
	30.3	150mm sweep	Each	5.00		
31		Removing the existing old exhaust fan and Supply, Installation, testing and commisioning of following sweep size Exhaust fan, single phase,1420 rpm fan with suitable mounting rings, brackets and resilient rubber cushions and with necessary fixtures and with self closing louvers, on the existing wall, including connection as required and having equivalent quality. Make:Almonard, Havells, Crompton, Orient, Khaithan.				
	31.1	450mm sweep	Each	20.00		
	31.2	300mm sweep	Each	10.00		
	31.3	150mm sweep	Each	5.00		
32		Supply and fixing of Electronic type 5 step speed regulator for AC, single phase, ceiling fan having equivalent quality of make: ANCHOR, USHA, Orient, POLAR, Kundan, FYBROS.	Each	120.00		

SL. NO	DESCRIPTION	UNIT	QUANTITY	Rate in Rs	Amount in Rs
33	Supply and Installation of 230v AC, single phase, double ball bearing, white/ivory colour ceiling fan of following size sweep with mounting ring, brackets and resilient rubber cushions and downrod of standard length (up to 30 cm) and wiring the down rods with 1.5sq.mm FR PVC, connection as required. and having equivalent quality of fan. make: Almonard, Usha, Crompton, Orient, Khaithan. (Fan should not be thread type head).				
	33.1 600mm sweep	Each	5.00		
	33.2 1200 mm sweep	Each	5.00		
34	Supply and Installation of FL / CFL of following rating of lamp fitting with lamp having equivalent quality of make: Havells, Philips, Wipro with fitting and necessary fixtures etc on wall/ceiling.				
	34.1 20W flourescent tube	Each	10.00		
	34.2 23W CFL	Each	10.00		
	34.3 18W CFL	Each	10.00		
	34.4 1x(36/40)W FL patti type fitting with lamp	Each	10.00		
	34.5 1x(36/40)W FL box type fitting with lamp	Each	10.00		
	34.6 2x(36/40)W FL box type fitting with lamp	Each	5.00		
35	Supply, installation, testing and commisioning of wall / column mounting, vertical type, 415V, TPN, MCB distribution board of sheet steel , dust protected duly phosphatized and powder painted, inclusive of 200Amps tinned copper Busbar, comman neutral link, earth bar, din bar for mounting MCB's, gland / knock out plate and with 100Amps, 10KA MCCB as incomer interconnection between incomer MCCB and busbar of following ways as required,without MCB. (where three phase outlets are required) and having equivalent quality of Make:GE, Siemens, MDS, legarnd, Havells .				
	35.1 4 way DB,100amps MCCB as incomer	Each	5.00		
	35.2 8 way DB,100amps MCCB as incomer	Each	2.00		
	35.3 12 way DB, 100amps MCCB as incomer	Each	2.00		
36	Supply and Erection of mettalic street light standard pole of length as follows in cement concrete 1:3:6 fountation with cement contrete collar of size 0.4m dia x 0.5m height to accomodate, pole with pipe bracket, coil earthing, 2 Nos of each 1.5 mtrs long GI pipe embedded on concrete suitable for taking out 2 core 16 / 10 sq.mm. PVCA Al. cable with necessary, looping cable end box, excavation and refilling etc, as required. (The Pole and MS Pipe bracket shall be Fabricated as per BHEL drawing nos:ES:M&S:1,2A and as per IS 2713(Part-I to Part-III)-1980).				
	36.1 Above 4.5 metre and upto 6.5 metre	Each	5.00		

SL. NO	DESCRIPTION	UNIT	QUANTITY	Rate in Rs	Amount in Rs
36.2	Above 8.0 metre and upto 10.0 metre	Each	5.00		
36.3	Above 10.0 metre and upto 12.0 metre	Each	3.00		
<b>END TERMINATION</b>					
37	Supply and making of end termination with brass single compression gland and aluminium lugs for following size of PVC insulated and PVC sheathed / XLPE aluminium armoured/unarmored conductor cable of 1.1KV grade as required				
	37.1	3 x 50 sq.mm	Each	20.00	
	37.2	3 x 300 sq.mm	Each	10.00	
	37.3	3.5 x 50 sq.mm	Each	20.00	
	37.4	3.5 x 70 sq.mm	Each	10.00	
	37.5	3.5 x 95 sq.mm	Each	40.00	
	37.6	3.5 x 185 sq.mm	Each	30.00	
	37.7	3.5 x 300 sq.mm	Each	35.00	
	37.8	4 x 16 sq.mm	Each	54.00	
38	Supply and making of end termination with brass single compression gland and copper lugs for following size of PVC insulated and PVC sheathed / XLPE copper armoured/unarmored conductor cable of 1.1KV grade as required.				
	38.1	3 x 50 sq.mm	Each	5.00	
	38.2	3.5 x 25 sq.mm	Each	80.00	
	38.3	3.5 x 35 sq.mm	Each	70.00	
	38.4	3.5 x 50 sq.mm	Each	10.00	
	38.5	3.5 x 70 sq.mm	Each	5.00	
	38.6	3.5 x 95 sq.mm	Each	10.00	
	38.7	3.5 x 120 sq.mm	Each	5.00	
	38.8	3.5 x 185 sq.mm	Each	10.00	
<b>SUPPLY AND WIRING</b>					
39	Supply and Wiring for light point / fan point / calling bell point with 1.5sq.mm FR PVC insulated copper conductor in surface / wall, with flush type switch, phenolic laminated sheet, suitable size MS box and earthing the point with 1.5sq.mm FR PVC insulated copper cable etc as required.(1 point shall be consider as 7metre distance more than 7metre shall be calculated in running metres as per SL.NO:55 & 56).				
	39.1	PVC conduit (open wiring)	Point	400.00	
	39.2	recessed PVC conduit (conceaed wiring)	Point	10.00	

SL. NO		DESCRIPTION	UNIT	QUANTITY	Rate in Rs	Amount in Rs
	39.3	PVC flat conduit	Point	10.00		
	39.4	using steel conduit	Point	10.00		
40		Supply and Wiring for twin control light point with 1.5sq.mm FR PVC insulated copper conductor in surface / wall, with 2 way flush type switch, phenolic laminated sheet, suitable size MS box and earthing the point with 1.5sq.mm FR PVC insulated copper cable etc as required.				
	40.1	using steel conduit	Point	5.00		
	40.2	PVC conduit	Point	5.00		
41		Rewiring for light point (1 way/2 way) / fan point / exhaust fan / calling bell / socket point with following size FR PVC insulated copper conductor and same size as earth wire in existing surface / wall / recess including dismantling as required.				
	41.1	1.5 sq.mm	Point	10.00		
	41.2	2.5 sqmm	Point	20.00		
<b>MAINTENANCE OF EARTH PIT AND ERECTION OF EARTH PIT</b>						
42		Corroded worn out damaged fasteners should be replaced with GI fasteners of not less than 8 mm by the contractor . If drilling is needed, the contractor shall bring their own drilling machine.	Pit	50.00		
43		Corroded / worn out funnels shall be replaced by the contractor wherever necessary.	Each	30.00		
44		Earthing with G.I pipe of 40mm dia 4500mm long, including accessories, and providing masonry enclosure with cover plate having locking arrangement and watering pipe etc, with charcoal and salt as required.(the size of pit, clamping and connections are as per drawing of BHEL:M&S:EL:PLNG:001-08.)				
	44.1	The Earth pit excavation may have to be done in <b>ordinary soil</b>	Each	5.00		
	44.2	The Earth pit excavation may have to be done in <b>soft rock</b>	Each	5.00		
	44.3	The Earth pit excavation may have to be done in <b>hard rock</b>	Each	25.00		
45		Replacing and fixing of 300 / 450 / 600mm Sweep, 3 Phase 415V Man cooler on existing iron frame, on column / wall with necessary fixtures etc. (Man cooler will be supplied by BHEL)	Each	10.00		

SL. NO	DESCRIPTION	UNIT	QUANTITY	Rate in Rs	Amount in Rs
<b>REMOVING</b>					
46	Removing of one number PVC insulated and PVC sheathed / XLPE armoured (COPPER /ALUMINIUM) power cable of 1.1KV grade of following sizes from underground including excavation, refilling the same trench etc as required.				
	46.1 <b>not exceeding 25sq.mm</b>	Metre	<b>50.00</b>		
	46.2 <b>exceeding 25 sq.mm but not exceeding 120 sq.mm</b>	Metre	<b>50.00</b>		
	46.3 <b>exceeding 120 sq.mm but not exceeding 400 sq.mm</b>	Metre	<b>100.00</b>		
47	Removing of one number PVC insulated and PVC sheathed / XLPE armoured (COPPER /ALUMINIUM) power cable of 1.1KV grade of following sizes from wall / trench / rack / floor.				
	47.1 <b>not exceeding 25sq.mm</b>	Metre	<b>1000.00</b>		
	47.2 <b>exceeding 25 sq.mm but not exceeding 120 sq.mm</b>	Metre	<b>1000.00</b>		
	47.3 <b>exceeding 120 sq.mm but not exceeding 400 sq.mm</b>	Metre	<b>750.00</b>		
48	Removing end termination of PVC insulated and PVC sheathed / XLPE armoured (COPPER /ALUMINIUM) power cable of 1.1KV grade.				
	48.1 <b>not exceeding 25sq.mm</b>	Each	<b>100.00</b>		
	48.2 <b>exceeding 25 sq.mm but not exceeding 120 sq.mm</b>	Each	<b>40.00</b>		
	48.3 <b>exceeding 120 sq.mm but not exceeding 400 sq.mm</b>	Each	<b>40.00</b>		
49	Removing of 1 x 40W, 2 x 40W box / patti type fitting from wall / ceiling and handing over the same to the department.	Each	<b>100.00</b>		
50	Removing of street light 250W HPSV/ HPMV MH / lamp fitting and lamp.	Each	<b>50.00</b>		
51	Removing of ceiling fans with regulator and handing over the same to the department.	Each	<b>50.00</b>		
52	Removing of 300 / 450 / 600mm Sweep, 3 Phase 415V Man cooler along with DOL starter and handing over the same to the department..	Each	<b>10.00</b>		
53	Removing of MCB DB/FDBs of 4/8/12ways 16A/32A/63A,from wall/steel structure etc.,	Each	<b>10.00</b>		
54	Removing of Isolators / Fuse Switch Units of 32/63/100/200/315 and 400A from wall/steel structure etc.,	Each	<b>30.00</b>		
55	Removing of old PVC conduit / steel conduit wirings and wires from surface / wall / recess and handing over to the section.	Metre	<b>1200.00</b>		

SL. NO	DESCRIPTION	UNIT	QUANTITY	Rate in Rs	Amount in Rs
56	Removing of wornout / damaged DSL insulator and replacing new DSL insulator with necessary fixtures. (Insulator will be supplied by BHEL free of cost).	Each	25.00		
<b>REPAIRING</b>					
57	Removing the light fittings from the location, replacing of bulb / ignitor /choke / starter and refixing the same after proving their performance. (All the spares components will be supplied by BHEL free of cost).				
57.1	1x40W FL. Fitting	Each	300.00		
57.2	2x40W(or)2x65W FL. Fitting	Each	50.00		
57.3	2x20 / 3x20 / 4x20 / 2x14 / 2x36 / 3x36W FL / CFL.	Each	50.00		
57.4	1x400W / 2x400W / 250W /125W HPMV / HPSV / MH light fitting	Each	400.00		
57.5	Hi mast light	Each	30.00		
57.6	Flame proof FL. Fitting	Each	5.00		
58	Without removing light fittings from the location, replacing bulb / ignitor /choke and proving their performance.(All the spare components will be supplied by BHEL free of cost) . 1x400W / 2x400W / 250W /125W / 2x14W / 2x36W / 3x36W / 40W FL / CFL / HPMV / HPSV / MH roof / column / wall / pole light fitting.	Each	400.00		
59	Removal, replacing the defective components in the following size fan and refixing the same at the original location after proving their performance. (All the spares components will be supplied by BHEL free of cost)				
59.1	up to510mm Exhaust fan	Each	20.00		
59.2	up to1200mm ceiling fan	Each	150.00		
<b>CLEANING</b>					
60	General cleaning of THREE PHASE column mounted /tubular man cooler in production shop floors.	Each	10.00		
61	General cleaning of SINGLE PHASE ceiling / pedestal fan.	Each	500.00		
62	General cleaning of cubicle cable trench (open the trench cover and cleaning and removing the unwanted items and covering the trench).	cu. metre	1200.00		
<b>MAINTENANCE OF EARTH PIT AND ERECTION OF EARTH PIT</b>					
63	Pouring 60 litres of water(approximately) in the funnel of every earth pit. (The required hose pipe and bucket shall be arranged by the contractor).	Pit	100.00		
64	Measurement of earth electrode resistance, Grid earth resistance values. The contractor shall bring the required periodically calibrated Earth Tester with leads, spikes, tools etc as per relevant IS.	Pit	200.00		

SL. NO	DESCRIPTION	UNIT	QUANTITY	Rate in Rs	Amount in Rs
65	Writing legibly the details of the reading on the earth pit cover. The details will be given by the concerned supervisor. The details shall be written .Good quality paint shall be used for background and white colour paint for lettering. (Paint and brush will be supplied by BHEL free of cost).	Pit	200.00		
66	Earth pits and its surrounding shall be cleaned by the contractor using their own tools.	Pit	200.00		
67	<b>Value of Schedule - B</b>				
68	Value of Free Issue Materilas ( APPROXIMATELY)			<b>Rs.</b>	<b>2750000</b>
69	Total (Assessable Value) of Schedule 'B' including free issue Materials as per SL.No (67)+(68) Rs.				
70	<b>Service Tax (on works contract) _____% (Contractor has quote service tax)</b>				
71	Total Value of Schedule 'B' as per SL. No (67) + (71)				<b>Rs.</b>
72	Grand Total Value of Schedule 'A' + Schedule 'B' as per Sl. No (23) + (71)				<b>Rs.</b>
<b>Note:</b>					
1. Contractor has to fill applicable service tax in SL. No 70.					
2. This Un-Price bid should be submitted along with Techno-Commercial Bid.					
3. The rate & amount should be quoted only in the PRICE – BID and to be submitted in a separate sealed cover along with the tender.					

# **TENDER DOCUMENT**

**TENDER NOTICE NO: BAP: M&S: TE: ELE: 14: 024: DT: 22.11.2014.**

<b>Name of work</b>	Electrical Petty Works at BHEL Ranipet.
<b>Period of Contract</b>	Two Years.

Issued to M/s:

## **PART – II – PRICE BID ( Pages 72 to 89 )**



**MAINTENANCE & SERVICES DEPARTMENT**  
**BHARAT HEAVY ELECTRICALS LIMITED**  
( A Government of India Undertaking )  
**BOILER AUXILIARIES PLANT**  
**INDIRA GANDHI INDUSTRIAL COMPLEX**  
**RANIPET – 632 406**



PRICE BID					
<b>Name of the Work:</b> Electrical Petty Works.					
<b>Period of Contract:</b> Two Years					
SCHEDULE - A					
SL. NO	DESCRIPTION	UNIT	QUANTITY	Rate in Rs	Amount in Rs
<b>LAYING OF CABLE IN UNDERGROUND</b>					
1	Laying of one number PVC insulated and PVC sheathed / XLPE armored/unarmored (COPPER /ALUMINIUM) power cable of 1.1KV grade of following sizes direct in ground including excavation, sand cushioning , protective covering and refilling the trench etc as required. (cable will be supplied by BHEL free of cost at stores)				
	1.1 <b>Up to 35 sq.mm</b>	Metre	<b>1000.00</b>	195.00	195000
	1.2 <b>Above 35 sq.mm and Upto 95 sq.mm</b>	Metre	<b>750.00</b>	202.00	151500
	1.3 <b>Above 95 sq.mm and Upto 185 sq.mm</b>	Metre	<b>750.00</b>	210.00	157500
	1.4 <b>Above 185 sq.mm and Upto 400 sq.mm</b>	Metre	<b>500.00</b>	233.00	116500
<b>LAYING OF ADDITIONAL CABLE IN SL.NO:1</b>					
2	Laying of one number additional PVC insulated and PVC sheathed / XLPE armored/unarmored (COPPER /ALUMINIUM) power cable of 1.1KV grade of following sizes direct in ground in the same trench in one tier horizontal formation including excavation ,sand cushioning ,protective covering and refilling the trench etc as required. (cable will be supplied by BHEL free of cost at stores)				
	2.1 <b>Up to 35 sq.mm</b>	Metre	<b>100.00</b>	133.00	13300
	2.2 <b>Above 35 sq.mm and Upto 95 sq.mm</b>	Metre	<b>200.00</b>	141.00	28200
	2.3 <b>Above 95 sq.mm and Upto 185 sq.mm</b>	Metre	<b>500.00</b>	149.00	74500
	2.4 <b>Above 185 sq.mm and Upto 400 sq.mm</b>	Metre	<b>200.00</b>	171.00	34200
<b>LAYING OF CABLE ON WALL SURFACE</b>					
3	Laying and fixing of one number PVC insulated and PVC sheathed / XLPE armored/unarmored (COPPER /ALUMINIUM) power cable of 1.1KV grade of following sizes on surface as required. (cable will be supplied by BHEL free of cost at stores).				
	3.1 <b>Up to 35 sq.mm (Clamped with 1mm thick saddle)</b>	Metre	<b>750.00</b>	24.00	18000
	3.2 <b>Above 35sq.mm and Up to 95 sq.mm (Clamped with 25x3mm MS flat Clamp)</b>	Metre	<b>500.00</b>	70.00	35000
	3.3 <b>Above 95sq.mm and Up to 185 sq.mm (Clamped with 25/40x3mm MS flat Clamp)</b>	Metre	<b>200.00</b>	81.00	16200
	3.4 <b>Above 185sq.mm and Up to 400 sq.mm (Clamped with 40x3mm MS flat Clamp)</b>	Metre	<b>100.00</b>	115.00	11500

SIGNATURE OF THE TENDERER WITH SEAL ADDRESS

SL. NO	DESCRIPTION	UNIT	QUANTITY	Rate in Rs	Amount in Rs
<b>LAYING OF CABLE ON CABLE TRAY</b>					
4	Laying and fixing of one number PVC insulated and PVC sheathed / XLPE armored/unarmored (COPPER /ALUMINIUM) power cable of 1.1KV grade of following sizes on Cable Tray as required. (cable will be supplied by BHEL free of cost at stores).				
	4.1 <b>Up to 35 sq.mm (Clamped with 1mm thick saddle)</b>		<b>500.00</b>	20.00	10000
	4.2 <b>Above 35sq.mm and Up to 95 sq.mm (Clamped with 25x3mm MS flat Clamp)</b>		<b>250.00</b>	48.00	12000
	4.3 <b>Above 95sq.mm and Up to 185 sq.mm (Clamped with 25/40x3mm MS flat Clamp)</b>		<b>200.00</b>	59.00	11800
	4.4 <b>Above 185sq.mm and Up to 400 sq.mm (Clamped with 40x3mm MS flat Clamp)</b>		<b>100.00</b>	91.00	9100
<b>LAYING OF CABLE IN GROUND WITHOUT SAND AND PROTECTIVE COVERING</b>					
5	Laying of one number PVC insulated and PVC sheathed / XLPE armored/unarmored (COPPER /ALUMINIUM) power cable of 1.1KV grade of following size direct in ground including excavation and refilling the trench, but excluding sand cushioning and protective covering. (cable will be supplied by BHEL free of cost at stores)				
	5.1 <b>Upto 35 sq.mm</b>	Metre	<b>300.00</b>	<b>87.00</b>	26100
	5.2 <b>Above 35 sq.mm and Upto 95 sq.mm</b>	Metre	<b>500.00</b>	<b>95.00</b>	47500
	5.3 <b>Above 95 sq.mm and Upto 185 sq.mm</b>	Metre	<b>500.00</b>	<b>102.00</b>	51000
	5.4 <b>Above 185 sq.mm and Upto 400 sq.mm</b>	Metre	<b>100.00</b>	<b>125.00</b>	12500
<b>LAYING OF CABLE IN RCC/HUME/METAL PIPE</b>					
6	Laying of one number PVC insulated and PVC sheathed / XLPE armored/unarmored (COPPER /ALUMINIUM) power cable of 1.1KV grade of following sizes in the existing RCC/HUME/METAL PIPE (cable will be supplied by BHEL free of cost from stores).				
	6.1 <b>Up to 35 sq.mm</b>	Metre	<b>750.00</b>	<b>16.00</b>	12000
	6.2 <b>Above 35sq.mm and Up to 95 sq.mm</b>	Metre	<b>500.00</b>	<b>25.00</b>	12500
	6.3 <b>Above 95sq.mm and Up to 185 sq.mm</b>	Metre	<b>200.00</b>	<b>33.00</b>	6600
	6.4 <b>Above 185sq.mm and Up to 400 sq.mm</b>	Metre	<b>100.00</b>	<b>58.00</b>	5800
<b>LAYING OF CABLE ON OPEN DUCT</b>					
7	Laying of one number PVC insulated and PVC sheathed / XLPE armored/unarmored (COPPER /ALUMINIUM) power cable of 1.1KV grade of following sizes in the existing masonry open dut as required. (cable will be supplied by BHEL free of cost from stores).				
	7.1 <b>Up to 35 sq.mm</b>	Metre	<b>500.00</b>	<b>12.00</b>	6000
	7.2 <b>Above 35sq.mm and Up to 95 sq.mm</b>	Metre	<b>500.00</b>	<b>20.00</b>	10000

SIGNATURE OF THE TENDERER WITH SEAL ADDRESS

SL. NO	DESCRIPTION	UNIT	QUANTITY	Rate in Rs	Amount in Rs
7.3	Above 95sq.mm and Up to 185 sq.mm	Metre	200.00	27.00	5400
7.4	Above 185sq.mm and Up to 400 sq.mm	Metre	100.00	50.00	5000
<b>INSATALLATION &amp; TESTING</b>					
8	Installation,testing and commissioning of pre-wired Flourescent fitting / CFL fitting of all types, complete with all accessories and tube etc.directly on ceiling / wall, including connection with 1.5sq.mm FR PVC insulation,copper conductor, single core cable and earthing etc, as required. (fitting and lamp will be supplied by BHEL free of cost).	Each	20.00	91.00	1820
9	Installation,testing and commissioning of resistance type ceiling fan regulator, in existing switch box including connection with 1.5sq.mm FRLS PVC insulation,copper conductor, single core cable and earthing the regulator etc, as required. (Regulator will be supplied by BHEL free of cost).	Each	10.00	52.00	520
<b>SUPPLY AND FIXING</b>					
10	Supply and fixing danger notice plate of following sizes, made of mild steel, at least 2 mm thick, and enamelled white on both sides, and with description in single red colour on front side as required.				
10.1	For Medium Voltage 200 mm x 150 mm	Each	10.00	141.00	1410
10.2	For High Voltage 250 mm x 200 mm	Each	10.00	155.00	1550
11	Supply and fixing cable route marker with 10cm x 10cm x 5cm thick G.I plate with inscription there on, bolted / welded to 35mm x 35mm x 6mm angle iron,60cm long and fixing the same in ground as required.	Each	50.00	288.00	14400
12	Supply and fixing of following sizes of Medium class PVC conduit along with accessories in surface / recess including cutting the wall and making good the same in case of recessed conduit as required.				
12.1	20 mm	Metre	150.00	53.00	7950
12.2	32 mm	Metre	50.00	85.00	4250
	50 mm	Metre	50.00	144.00	7200
13	Supply and replacing the defective switch/socket and fixing a new switch / socket on the existing switch box and having equivalent quality of Make : Anchor , GM , Havells.				
13.1	5/6 amps switch.	Each	500.00	33.00	16500
13.2	15/16 amps switch.	Each	50.00	72.00	3600

SIGNATURE OF THE TENDERER WITH SEAL ADDRESS

SL. NO	DESCRIPTION	UNIT	QUANTITY	Rate in Rs	Amount in Rs
13.3	5/6 amps socket outlet.	Each	<b>500.00</b>	41.00	20500
13.4	6 pin 15/16 amps socket outlet.	Each	<b>30.00</b>	83.00	2490
14	Supply and Wiring for circuit / submain wiring along earth wire with the following sizes of FRLS PVC insulated copper conductor single core cable in surface / wall with recessed <b>steel conduit</b> , as required.				
14.1	(2 x 1.5 sq.mm ) + (1 x 1.5 sq.mm Earth wire)	Metre	<b>400.00</b>	175.00	70000
14.2	(2 x 2.5 sq.mm ) + (1 x 2.5 sq.mm Earth wire)	Metre	<b>750.00</b>	200.00	150000
15	Supply and Wiring for circuit / submain wiring along earth wire with the following sizes of FRLS PVC insulated copper conductor single core cable in surface / wall with recessed 2mm thick <b>PVC conduit</b> , as required.				
15.1	(2 x 1.5 sq.mm ) + (1 x 1.5 sq.mm Earth wire)	Metre	<b>2500.00</b>	106.00	265000
15.2	(2 x 2.5 sq.mm ) + (1 x 2.5 sq.mm Earth wire)	Metre	<b>3000.00</b>	131.00	393000
16	<b>Value of Schedule - A</b>				<b>2054890</b>
17	<b>CONTRACTOR'S TENDER PERCENTAGE</b>	Indicate %	Note	Please Tick	Indicate Amount
		_____ %	BELOW	B1	(-)
			ABOVE	B2	(+)
			AT PAR	B3	(=) 0.00
18	Tender Percentage in Words _____				
19	Sub Total value of schedule 'A' as per SL . No (16 ± 17 )			<b>Rs.</b>	
20	Value of Free Issue Materilas ( APPROXIMATELY)			<b>Rs.</b>	35,00,000
21	Total (Assessable Value) of Schedule 'A' including free issue Materials as per SL.No (19) + (20)				<b>Rs.</b>
22	Service Tax (on works contract) _____ %			<b>Rs.</b>	
23	Total value of schedule 'A' as per SL. No (19) + (22)			<b>Rs.</b>	

SIGNATURE OF THE TENDERER WITH SEAL ADDRESS

PRICE BID						
Name of the Work: Electrical Petty Works.						
Period of Contract: Two Years						
SCHEDULE - B						
SL. NO		DESCRIPTION	UNIT	QUANTITY	Rate in Rs	Amount in Rs
<b>SUPPLY AND MAKING JOINTS</b>						
1		Supply and making straight through joints with cast resin compound including ferrules and other jointing materials for following size of PVC insulated and PVC sheathed / XLPE <b>aluminium</b> armored/unarmored conductor cable of 1.1KV grade as required.				
	1.1	<b>3 x 50 sq.mm</b>	Each	<b>5.00</b>		
	1.2	<b>3.5 x 50 sq.mm</b>	Each	<b>5.00</b>		
	1.3	<b>3.5 x 70 sq.mm</b>	Each	<b>5.00</b>		
	1.4	<b>3.5 x 95 sq.mm</b>	Each	<b>5.00</b>		
	1.5	<b>3.5 x 185 sq.mm</b>	Each	<b>10.00</b>		
	1.6	<b>3.5 x 300 sq.mm</b>	Each	<b>3.00</b>		
<b>INSTALLATION &amp; TESTING</b>						
2		Installation and testing of 1x400W / 2x400W / 250W /125W HPMV / HPSV / MH light fitting with lamp,of all type on the column / wall / post / tower / roof with down rod, supporting angle, necessary fixtures etc. (Supply of downrod and supporting angle will be contractor scope). (fitting and lamp will be supplied by BHEL free of cost) at stores.	Each	<b>150.00</b>		
3		Installation,testing and commissioning of ceiling fan and regulator including supply and wiring the down rods of standard length (up to 30 cm) with 1.5sq.mm FRLS PVC insulation, copper conductor, single core cable and earthing etc, as required. (Supply of downrod will be contractor scope) (fan will be supplied by BHEL free of cost) at stores.	Each	<b>60.00</b>		
4		Erection of 400/800Amps MAIN PANEL of following sizes a) Necessary MS channel of size 100mmx50mm shall be supplied and provided for the erection of MP atleast 1support for a length of 1 metre. b) The support channels shall be neatly fixed across the cable trench, by welding or grouting. c) The MS channels shall be thoroughly cleaned and painted with one coat of red-oxide and two coat of enamelled paint as required. (The main panel alone will be supplied by BHEL free of cost) ar stores.				
	4.1	2Metre length	Each	<b>1.00</b>		

SL. NO		DESCRIPTION	UNIT	QUANTITY	Rate in Rs	Amount in Rs
	4.2	3Metre length	Each	1.00		
	4.3	4Metre length	Each	1.00		
	4.4	5Metre length	Each	1.00		
5		Fixing of following ways 63A per way TPN HRC fuse distribution board with following rating of ICTPN as incomer with top and bottom entry MS cable adoptor box on suitable iron frame work or iron frame stand to be fixed on the concrete floor with necessary inter-connection,masonry work and etc as required. (Iron frame and adoptor will be contractor scope). (The DB and ICTPN will be supplied by BHEL free of cost) at stores.				
	5.1	4 way DB,100A ICTPN as incomer	Each	3.00		
	5.2	8 way DB,200A ICTPN as incomer	Each	3.00		
6		Fixing of following ways 32A per way TPN HRC fuse distribution board with following rating of ICTPN as incomer with top and bottom entry MS cable adoptor box on suitable iron frame work or iron frame stand to be fixed on the concrete floor with necessary inter-connection,masonry work and etc as required. (Iron frame and adoptor will be contractor scope), (The DB and ICTPN will be supplied by BHEL free of cost) at stores.				
	6.1	4 way DB, 63A ICTPN as incomer	Each	5.00		
	6.2	8 way DB, 100A ICTPN as incomer	Each	5.00		
	6.3	12 way DB, 200 ICTPN as incomer	Each	3.00		
7		Fixing of following ways 16A/20A per way TPN HRC fuse distribution board with following rating of ICTPN as incomer with top and bottom entry MS cable adoptor box on suitable iron frame work or iron frame stand to be fixed on the concrete floor with necessary inter-connection,masonry work and etc as required. (Iron frame and adoptor will be contractor scope), (The DB and ICTPN will be supplied by BHEL free of cost) at stores.				
	7.1	8 way DB, 63A ICTPN as incomer	Each	3.00		
	7.2	12 way DB, 100A ICTPN as incomer	Each	3.00		

SL. NO		DESCRIPTION	UNIT	QUANTITY	Rate in Rs	Amount in Rs
8		Fixing of 300 / 450 / 600mm Sweep, 3 Phase 415V Man cooler along with suitable DOL starter on iron frame work, with 3 pole 6 amps MCB, in 2mm thick MS box, the iron frame and MS box to be fixed on column / wall with necessary fixtures etc. (Man cooler and starter will be supplied by BHEL) at stores, (MS box and MCB will be contractor scope) .	Each	15.00		
9		Installation, testing and commisioning of Exhaust fans up to 510mm sweep single phase by making holes to suit on the wall, required masonary work to making good the damage, including connection as required. (Exhaust fan will be supplied by BHEL) at stores.	Each	10.00		
10		Fixing of following capacity ICTPN/LPTPN type disconnecter fuse switch unit on the existing cubicle panel board with MS cable entry adoptor box (top/bottom) with necessary fixtures etc, including drilling holes in cubicle panel, making connections, etc as required. (supply of Adaptor box is contractor scope). (ICTPN/LPTPN will be supplied by BHEL) at stores.				
	10.1	32 Amp TPN / FP	Each	5.00		
	10.2	63 Amp TPN / FP	Each	5.00		
	10.3	100 Amp TPN	Each	5.00		
	10.4	200 Amp TPN	Each	5.00		
	10.5	315/400 Amp TPN	Each	5.00		
11		Fixing following capacity ICTPN / LPTPN type disconnecter fuse switch unit on suitable iron frame work on floor/wall/column with (2 mm thick) MS cable entry adoptor box on (top and bottom) with necessary inter-connection,masonary work and etc as required. (supply of Adaptor box and iron frame will be contractor scope). (ICTPN/LPTPN will be supplied by BHEL) at stores.				
	11.1	32 Amp TP&N	Each	5.00		
	11.2	63 Amp TP&N	Each	10.00		
	11.3	100 Amp TP&N	Each	5.00		
	11.4	200 Amp TP&N	Each	5.00		
	11.5	315/400 Amp TPN	Each	2.00		

SL. NO	DESCRIPTION	UNIT	QUANTITY	Rate in Rs	Amount in Rs
12	Numbering of ceiling fan / exhaust fan / flourescent fittings as required. Make: nerolac, asian, tractor. (paint, brush will be contractor scope).	Each	50.00		
13	Supply and painting with one coat of red oxide as primer and two coats of synthetic enamel of selected colour on metal surfaces of Transformers/ DB / MP / Isolators / Street Light Pole / Fencing / Steel structures/ Angles / Bracing / Column etc. with Paint having equivalent quality of make:nerolac, asian, tractor.	sq ft	5000.00		
<b>SUPPLY AND FIXING</b>					
14	Supply and fixing of galvanized MS (2mm thick plate) cable tray of size 200mm width and 150mm height with cover on ground using jumber bolt.	Mtr	20		
15	Supply and fixing suitable clamps and necessary fixtures for existing PVC / STEEL (19mm/24mm/36mm)conduits on wall / surface / column.	Metre	50.00		
16	Supplying and fixing of metal box (2mm thick) with cover of following sizes (Nominal size) on surface / wall / recess with Phosphatized and powder painted, locking facility as required.				
16.1	100 mm x 100 mm x 60 mm deep	Each	30.00		
16.2	200 mm x 250 mm x 60 mm deep	Each	75.00		
16.3	200 mm x 150 mm x 100 mm deep	Each	20.00		
	250 mm x 300 mm x 60 mm deep	Each	25.00		
17	Supply and replacing / fixing of following rating of socket and switch on following size of metal box (nominal size) on surface / wall / column / recess with suitable size of phenolic laminated sheet cover in front including providing and fixing ,interconnections,painting etc as required.				
17.1	MS box of 150 mm x 75 mm x 60 mm deep, 5 / 6 Amps socket outlet and flushtype switch	No.	20.00		
17.2	MS box of 180 mm x 100 mm x 60 mm deep, 15 / 16 Amps socket outlet and flushtype switch	No.	75.00		



SL. NO	DESCRIPTION	UNIT	QUANTITY	Rate in Rs	Amount in Rs
18	Supplying and fixing following way, single pole and neutral, sheet steel, MCB distribution board, 240 volts, on surface / wall / column /recess, complete with tinned copper busbar, neutral busbar, earth bar, din bar, detachable gland plate, interconnections, phosphatized and powder painted including earthing, as required.(with out MCB) and having equivalent quality of make:GE,MDS,Siemens, legrand,Havells, Kundan,Fybros.				
	4 way ,single door	Each	5.00		
	18.1 8 way ,single door	Each	5.00		
	18.2 12 way ,single door	Each	5.00		
19	Supplying and fixing 4way, single door, horizontal type three pole and neutral, sheet steel, MCB distribution board, 415 volts, on surface / wall /recess, complete with tinned copper busbar, neutral busbar, earth bar, din bar, detachable gland plate, interconnections, phosphatized and powder painted including earthing, as required.(with out MCB) and having equivalent quality of MCB make:GE, MDS, Siemens, legrand, Havells, Kundan, Fybros.	Each	5.00		
20	Supplying and fixing 5 Amps to 32 Amps rating, 240 / 415 volts, 'C' Curve, MCB suitable for inductive load of following poles in the existing MCB DB, complete with connections, testing and commissioning etc, as required and having equivalent quality of MCB make:GE,MDS,Siemens,legrand,Havells,Kundan, Fybros.				
	20.1 Single pole	Each	50.00		
	20.2 Double pole	Each	25.00		
	20.3 Triple pole	Each	10.00		
	20.4 Triple pole & neutral	Each	10.00		
21	Supplying and fixing following rating double pole MCB, 240 volts, in the existing MCB DB, complete with connections, testing and commissioning etc, as required and having equivalent quality of MCB make:GE,MDS,Siemens,legrand,Havells,Kundan, Fybros.				
	21.1 40 amps	Each	5.00		
	21.2 63 amps	Each	5.00		
22	Supplying and fixing following rating four pole MCB, 415 volts, in the existing MCB DB, complete with connections, testing and commissioning etc, as required and having equivalent quality of MCB make:GE,MDS,Siemens,legrand,Havells,Kundan, Fybros.				
	22.1 40 amps	Each	5.00		
	22.2 63 amps	Each	5.00		

SL. NO	DESCRIPTION	UNIT	QUANTITY	Rate in Rs	Amount in Rs
23	Supply and fixing of following rating of MCB with connection and earthing and necessary fixtures as required and having equivalent quality of MCB. MAKE:GE,MDS,Siemens,legrand,Havells,Kundan, Fybros.				
	23.1 63Amps TPN MCB On the existing distribution board/MS box	Each	5.00		
	23.2 32Amps TPN MCB On the existing distribution board/MS box	Each	5.00		
	23.3 32Amps DP MCB On the existing distribution board/MS box	Each	5.00		
	23.4 25Amps TPN MCB On the existing distribution board/MS box	Each	5.00		
	23.5 25Amps DP MCB On the existing distribution board/MS box	Each	5.00		
24	Supplying and fixing of metal clad socket of Best & Crompton / Sakthi Crown make with plug top along with suitable rating MCB as given, in 2mm thick MS box, on surface / wall / recess / Column / ground, with cover for the socket outlet and complete with connections, testing and commissioning etc, as required and having equivalent quality of MCB. make:GE, MDS, Siemens, legrand, Havells, Kundan, Fybros.				
	24.1 1phase, 3 pin, 10 Amps socket & plug top and 10 Amps DP MCB.	Each	20.00		
	24.2 1phase, 3 pin, 20 Amps socket & plug top and 20 Amps DP MCB.	Each	25.00		
	24.3 3phase, 4 pin, 20 Amps socket & plug top and 20 Amps TP MCB.	Each	25.00		
	24.4 3phase, 4 pin, 30 Amps socket & plug top and 30 Amps TP MCB.	Each	20.00		
25	Supplying and fixing three phase 30 Amps ,415 volt, 5-pin TPN industrial type socket outlet with 4pole and earth metal enclosed plug top along with 30Amps MCB, c curve TPMCB in sheet steel enclosure or in recess, with chinel metal cover, for the socket outlet and complete with connections, testing and commissioning etc, as required and having equivalent quality of MCB make:GE,MDS,Siemens,legrand,Havells,Kundan, Fybros.	Each	25.00		
26	Supply & fixing steel wire mesh for three phase column mounted / tabular / pedestal mancoolers with necessary binding wires etc.,	Each	20.00		
	Supply and laying of following earth strip / wire / bus on surface / wall / recess connections as required.				
	27.1 50x6mm GI flat for earthing.	Metre	200.00		
	27.2 25x6mm GI flat for earthing.	Metre	500.00		

SL. NO		DESCRIPTION	UNIT	QUANTITY	Rate in Rs	Amount in Rs
27	27.3	25mm x 5mm G.I earth strip	Metre	50.00		
	27.4	25x3mm GI flat for earthing.	Metre	500.00		
	27.5	8 SWG GI wire	Metre	600.00		
	27.6	14 SWG G.I wire	Metre	50.00		
	27.7	8 SWG copper wire	Metre	50.00		
	27.8	14 SWG Bare Copper wire	Metre	300.00		
	27.9	25mm x 6 mm copper flat	Metre	20.00		
	27.10	50mm x 6 mm copper flat	Metre	20.00		
28		Supply and fixing of weather proof (2mm thick) MS box of size 200mm height x 240mm length x 150mm depth with one coat of red oxide and 2 coat of alu. paint for street light with 1 No of 15A fuse carrier and 6 way 15A connector.	Each	75.00		
29		Supply and fixing calling bell / buzzer suitable for single phase, 230v, complete as required.	Each	5.00		
30		Supply, Installation, testing and commissioning of following sweep size Exhaust fan, single phase, 1420 rpm fan with suitable mounting rings, brackets and resilient rubber cushions and with necessary fixtures and with self closing louvers, by making holes to suit on the wall, making good the damage, including connection as required and having equivalent quality. Make: Almonard, Havells, Crompton, Orient, Khaithan.				
	30.1	450mm sweep	Each	20.00		
	30.2	300mm sweep	Each	10.00		
	30.3	150mm sweep	Each	5.00		
31		Removing the existing old exhaust fan and Supply, Installation, testing and commissioning of following sweep size Exhaust fan, single phase, 1420 rpm fan with suitable mounting rings, brackets and resilient rubber cushions and with necessary fixtures and with self closing louvers, on the existing wall, including connection as required and having equivalent quality. Make: Almonard, Havells, Crompton, Orient, Khaithan.				
	31.1	450mm sweep	Each	20.00		
	31.2	300mm sweep	Each	10.00		
	31.3	150mm sweep	Each	5.00		
32		Supply and fixing of Electronic type 5 step speed regulator for AC, single phase, ceiling fan having equivalent quality of make: ANCHOR, USHA, Orient, POLAR, Kundan, FYBROS.	Each	120.00		

SL. NO	DESCRIPTION	UNIT	QUANTITY	Rate in Rs	Amount in Rs
33	Supply and Installation of 230v AC, single phase, double ball bearing, white/ivory colour ceiling fan of following size sweep with mounting ring, brackets and resilient rubber cushions and downrod of standard length (up to 30 cm) and wiring the down rods with 1.5sq.mm FR PVC, connection as required. and having equivalent quality of fan. make: Almonard, Usha, Crompton, Orient, Khaithan. (Fan should not be thread type head).				
	33.1 600mm sweep	Each	5.00		
	33.2 1200 mm sweep	Each	5.00		
34	Supply and Installation of FL / CFL of following rating of lamp fitting with lamp having equivalent quality of make: Havells, Philips, Wipro with fitting and necessary fixtures etc on wall/ceiling.				
	34.1 20W flourescent tube	Each	10.00		
	34.2 23W CFL	Each	10.00		
	34.3 18W CFL	Each	10.00		
	34.4 1x(36/40)W FL patti type fitting with lamp	Each	10.00		
	34.5 1x(36/40)W FL box type fitting with lamp	Each	10.00		
	34.6 2x(36/40)W FL box type fitting with lamp	Each	5.00		
35	Supply, installation, testing and commisioning of wall / column mounting, vertical type, 415V, TPN, MCB distribution board of sheet steel , dust protected duly phosphatized and powder painted, inclusive of 200Amps tinned copper Busbar, comman neutral link, earth bar, din bar for mounting MCB's, gland / knock out plate and with 100Amps, 10KA MCCB as incomer interconnection between incomer MCCB and busbar of following ways as required,without MCB. (where three phase outlets are required) and having equivalent quality of Make:GE, Siemens, MDS, legarnd, Havells .				
	35.1 4 way DB,100amps MCCB as incomer	Each	5.00		
	35.2 8 way DB,100amps MCCB as incomer	Each	2.00		
	35.3 12 way DB, 100amps MCCB as incomer	Each	2.00		
36	Supply and Erection of mettalic street light standard pole of length as follows in cement concrete 1:3:6 fountation with cement contrete collar of size 0.4m dia x 0.5m height to accomodate, pole with pipe bracket, coil earthing, 2 Nos of each 1.5 mtrs long GI pipe embedded on concrete suitable for taking out 2 core 16 / 10 sq.mm. PVCA Al. cable with necessary, looping cable end box, excavation and refilling etc, as required. (The Pole and MS Pipe bracket shall be Fabricated as per BHEL drawing nos:ES:M&S:1,2A and as per IS 2713(Part-I to Part-III)-1980).				
	36.1 Above 4.5 metre and upto 6.5 metre	Each	5.00		

SL. NO		DESCRIPTION	UNIT	QUANTITY	Rate in Rs	Amount in Rs
	36.2	Above 8.0 metre and upto 10.0 metre	Each	5.00		
	36.3	Above 10.0 metre and upto 12.0 metre	Each	3.00		
<b>END TERMINATION</b>						
37		Supply and making of end termination with brass single compression gland and aluminium lugs for following size of PVC insulated and PVC sheathed / XLPE aluminium armoured/unarmored conductor cable of 1.1KV grade as required				
	37.1	3 x 50 sq.mm	Each	20.00		
	37.2	3 x 300 sq.mm	Each	10.00		
	37.3	3.5 x 50 sq.mm	Each	20.00		
	37.4	3.5 x 70 sq.mm	Each	10.00		
	37.5	3.5 x 95 sq.mm	Each	40.00		
	37.6	3.5 x 185 sq.mm	Each	30.00		
	37.7	3.5 x 300 sq.mm	Each	35.00		
	37.8	4 x 16 sq.mm	Each	54.00		
38		Supply and making of end termination with brass single compression gland and copper lugs for following size of PVC insulated and PVC sheathed / XLPE copper armoured/unarmored conductor cable of 1.1KV grade as required.				
	38.1	3 x 50 sq.mm	Each	5.00		
	38.2	3.5 x 25 sq.mm	Each	80.00		
	38.3	3.5 x 35 sq.mm	Each	70.00		
	38.4	3.5 x 50 sq.mm	Each	10.00		
	38.5	3.5 x 70 sq.mm	Each	5.00		
	38.6	3.5 x 95 sq.mm	Each	10.00		
	38.7	3.5 x 120 sq.mm	Each	5.00		
	38.8	3.5 x 185 sq.mm	Each	10.00		
<b>SUPPLY AND WIRING</b>						
39		Supply and Wiring for light point / fan point / calling bell point with 1.5sq.mm FR PVC insulated copper conductor in surface / wall, with flush type switch, phenolic laminated sheet, suitable size MS box and earthing the point with 1.5sq.mm FR PVC insulated copper cable etc as required.(1 point shall be consider as 7metre distance more than 7metre shall be calculated in running metres as per SL.NO:55 & 56).				
	39.1	PVC conduit (open wiring)	Point	400.00		
	39.2	recessed PVC conduit (conceaed wiring)	Point	10.00		

SL. NO		DESCRIPTION	UNIT	QUANTITY	Rate in Rs	Amount in Rs
	39.3	PVC flat conduit	Point	10.00		
	39.4	using steel conduit	Point	10.00		
40		Supply and Wiring for twin control light point with 1.5sq.mm FR PVC insulated copper conductor in surface / wall,with 2 way flush type switch, phenolic laminated sheet, suitable size MS box and earthing the point with 1.5sq.mm FR PVC insulated copper cable etc as required.				
	40.1	using steel conduit	Point	5.00		
	40.2	PVC conduit	Point	5.00		
41		Rewiring for light point (1 way/2 way) / fan point / exhaust fan / calling bell / socket point with following size FR PVC insulated copper conductor and same size as earth wire in existing surface / wall / recess including dismantling as required.				
	41.1	1.5 sq.mm	Point	10.00		
	41.2	2.5 sqmm	Point	20.00		
<b>MAINTENANCE OF EARTH PIT AND ERECTION OF EARTH PIT</b>						
42		Corroded worn out damaged fasteners should be replaced with GI fasteners of not less than 8 mm by the contractor . If drilling is needed, the contractor shall bring their own drilling machine.	Pit	50.00		
43		Corroded / worn out funnels shall be replaced by the contractor wherever necessary.	Each	30.00		
44		Earthing with G.I pipe of 40mm dia 4500mm long, including accessories, and providing masonry enclosure with cover plate having locking arrangement and watering pipe etc, with charcoal and salt as required.(the size of pit,clamping and connections are as per drawing of BHEL:M&S:EL:PLNG:001-08.)				
	44.1	The Earth pit excavation may have to be done in <b>ordinary soil</b>	Each	5.00		
	44.2	The Earth pit excavation may have to be done in <b>soft rock</b>	Each	5.00		
	44.3	The Earth pit excavation may have to be done in <b>hard rock</b>	Each	25.00		
45		Replacing and fixing of 300 / 450 / 600mm Sweep, 3 Phase 415V Man cooler on existing iron frame, on column / wall with necessary fixtures etc. (Man cooler will be supplied by BHEL)	Each	10.00		

SL. NO	DESCRIPTION	UNIT	QUANTITY	Rate in Rs	Amount in Rs
<b>REMOVING</b>					
46	Removing of one number PVC insulated and PVC sheathed / XLPE armoured (COPPER /ALUMINIUM) power cable of 1.1KV grade of following sizes from underground including excavation, refilling the same trench etc as required.				
	46.1 <b>not exceeding 25sq.mm</b>	Metre	<b>50.00</b>		
	46.2 <b>exceeding 25 sq.mm but not exceeding 120 sq.mm</b>	Metre	<b>50.00</b>		
	46.3 <b>exceeding 120 sq.mm but not exceeding 400 sq.mm</b>	Metre	<b>100.00</b>		
47	Removing of one number PVC insulated and PVC sheathed / XLPE armoured (COPPER /ALUMINIUM) power cable of 1.1KV grade of following sizes from wall / trench / rack / floor.				
	47.1 <b>not exceeding 25sq.mm</b>	Metre	<b>1000.00</b>		
	47.2 <b>exceeding 25 sq.mm but not exceeding 120 sq.mm</b>	Metre	<b>1000.00</b>		
	47.3 <b>exceeding 120 sq.mm but not exceeding 400 sq.mm</b>	Metre	<b>750.00</b>		
48	Removing end termination of PVC insulated and PVC sheathed / XLPE armoured (COPPER /ALUMINIUM) power cable of 1.1KV grade.				
	48.1 <b>not exceeding 25sq.mm</b>	Each	<b>100.00</b>		
	48.2 <b>exceeding 25 sq.mm but not exceeding 120 sq.mm</b>	Each	<b>40.00</b>		
	48.3 <b>exceeding 120 sq.mm but not exceeding 400 sq.mm</b>	Each	<b>40.00</b>		
49	Removing of 1 x 40W, 2 x 40W box / patti type fitting from wall / ceiling and handing over the same to the department.	Each	<b>100.00</b>		
50	Removing of street light 250W HPSV/ HPMV MH / lamp fitting and lamp.	Each	<b>50.00</b>		
51	Removing of ceiling fans with regulator and handing over the same to the department.	Each	<b>50.00</b>		
52	Removing of 300 / 450 / 600mm Sweep, 3 Phase 415V Man cooler along with DOL starter and handing over the same to the department..	Each	<b>10.00</b>		
53	Removing of MCB DB/FDBs of 4/8/12ways 16A/32A/63A,from wall/steel structure etc.,	Each	<b>10.00</b>		
54	Removing of Isolators / Fuse Switch Units of 32/63/100/200/315 and 400A from wall/steel structure etc.,	Each	<b>30.00</b>		
55	Removing of old PVC conduit / steel conduit wirings and wires from surface / wall / recess and handing over to the section.	Metre	<b>1200.00</b>		

SL. NO	DESCRIPTION	UNIT	QUANTITY	Rate in Rs	Amount in Rs
56	Removing of wornout / damaged DSL insulator and replacing new DSL insulator with necessary fixtures. (Insulator will be supplied by BHEL free of cost).	Each	25.00		
<b>REPAIRING</b>					
57	Removing the light fittings from the location, replacing of bulb / ignitor /choke / starter and refixing the same after proving their performance. (All the spares components will be supplied by BHEL free of cost).				
	57.1 1x40W FL. Fitting	Each	300.00		
	57.2 2x40W(or)2x65W FL. Fitting	Each	50.00		
	57.3 2x20 / 3x20 / 4x20 / 2x14 / 2x36 / 3x36W FL / CFL.	Each	50.00		
	57.4 1x400W / 2x400W / 250W /125W HPMV / HPSV / MH light fitting	Each	400.00		
	57.5 Hi mast light	Each	30.00		
	57.6 Flame proof FL. Fitting	Each	5.00		
58	Without removing light fittings from the location, replacing bulb / ignitor /choke and proving their performance.(All the spare components will be supplied by BHEL free of cost) . 1x400W / 2x400W / 250W /125W / 2x14W / 2x36W / 3x36W / 40W FL / CFL / HPMV / HPSV / MH roof / column / wall / pole light fitting.	Each	400.00		
59	Removal, replacing the defective components in the following size fan and refixing the same at the original location after proving their performance. (All the spares components will be supplied by BHEL free of cost)				
	59.1 up to510mm Exhaust fan	Each	20.00		
	59.2 up to1200mm ceiling fan	Each	150.00		
<b>CLEANING</b>					
60	General cleaning of THREE PHASE column mounted /tubular man cooler in production shop floors.	Each	10.00		
61	General cleaning of SINGLE PHASE ceiling / pedestal fan.	Each	500.00		
62	General cleaning of cubicle cable trench (open the trench cover and cleaning and removing the unwanted items and covering the trench).	cu. metre	1200.00		
<b>MAINTENANCE OF EARTH PIT AND ERECTION OF EARTH PIT</b>					
63	Pouring 60 litres of water(approximately) in the funnel of every earth pit. (The required hose pipe and bucket shall be arranged by the contractor).	Pit	100.00		
64	Measurement of earth electrode resistance, Grid earth resistance values. The contractor shall bring the required periodically calibrated Earth Tester with leads, spikes, tools etc as per relevant IS.	Pit	200.00		



SL. NO	DESCRIPTION	UNIT	QUANTITY	Rate in Rs	Amount in Rs
65	Writing legibly the details of the reading on the earth pit cover. The details will be given by the concerned supervisor. The details shall be written .Good quality paint shall be used for background and white colour paint for lettering. (Paint and brush will be supplied by BHEL free of cost).	Pit	200.00		
66	Earth pits and its surrounding shall be cleaned by the contractor using their own tools.	Pit	200.00		
67	<b>Value of Schedule - B</b>				
68	Value of Free Issue Materilas ( APPROXIMATELY)			<b>Rs.</b>	<b>2750000</b>
69	Total (Assessable Value) of Schedule 'B' including free issue Materials as per SL.No <b>(67)+(68) Rs.</b>				
70	Service Tax (on works contract)_____%			<b>Rs.</b>	
71	Total Value of Schedule 'B' as per SL. No <b>(67) + (70)</b>				<b>Rs.</b>
72	Grand Total Value of Schedule 'A' + Schedule 'B' as per Sl. No <b>(23) + (71)</b>				<b>Rs.</b>

## **SAFETY RULES**

1. The Contractor must inspect the area of work to decide the safety precautions necessary for executing this contract.
2. Whenever people work at height more than six feet, platform shall be provided or the workers shall wear safety belt to avoid fall from the height.
3. Wherever any area declared dangerous, the workers shall not be allowed to work till a written clearance is obtained from appropriate authorities.
4. No material of any kind shall be dropped or allowed to be dropped from any height.
5. Defective ladders shall not be used at all.
6. Inflammable materials shall not be stored near places where the sparks are likely to occur.
7. The necessary safety equipments such as gloves, safety belt, helmet, safety boot etc must be issued to the workmen and strictly to be used while carryout the work. If Personal Protection Equipments not provided by the contractor, BHEL shall provide the required PPEs on chargeable basis, depending upon the stock availability.
8. If the contractor's workmen found violating the safety precautions, punitive action will be taken and or a penalty of Rs.500/- will be imposed and deducted from the contractor bill for each violation.
9. The working area shall be kept clean and free from all obstructions.
10. All safety precautions are to be taken by the contractor at his cost.

These safety measures shall be deemed to form an integral part of the Work Order/ Agreement.



**ACCEPTANCE FOR ELECTRONIC FUND TRANSFER / RTGS TRANSFER**

01	<b>NAME &amp; ADDRESS OF THE SUPPLIER / VENDOR PHONE NO. WITH STD CODE</b>	
02	<b>VENDOR CODE</b> (as in WORK ORDER)	<input type="text"/>
03	<b>Details of Bank Account:</b>	
A)	<b>NAME &amp; ADDRESS OF THE BANK</b> (WITH PIN CODE)	
B)	<b>BANK TELEPHONE NUMBER</b> (WITH STD CODE)	<input type="text"/>
C)	<b>BANK BRANCH CODE:</b>	<input type="text"/>
D)	<b>MICR CODE</b>	<input type="text"/>
E)	<b>ACCOUNT NUMBER</b>	<input type="text"/>
F)	<b>TYPE OF ACCOUNT</b>	CURRENT / OD / CASH CREDIT
G)	<b>VENDOR NAME AS PER BANK RECORDS</b>	
H)	<b>BANK BRANCH RTGS IFSC CODE</b>	<input type="text"/>
I)	<b>BANK BRANCH NEFT IFSC CODE</b>	<input type="text"/>
J)	<b>VENDOR'S EMAIL ID</b> (give two ids)	<input type="text"/> <input type="text"/>
K)	<b>NAME OF AUTHORISED SIGNATORY</b>	

**CERTIFICATE**

I / We hereby agree to receive the payments due from BHARAT HEAVY ELECTRICALS LIMITED, RANIPET by the National Electronic Funds Transfer and/or RTGS Transfer mode by credit to my / our above mentioned Bank Account. I / We also agree that payments made to the above mentioned Account is a valid discharge of the liability of Bharat Heavy Electricals Limited, Ranipet. I / we also agree to bear the applicable Bank Charges for the above mode of transfer.

AUTHORISED SIGNATORY OF VENDOR WITH SEAL

**Banker's Certification**

We confirm that we are enabled for receiving RTGS and NEFT credits and we further confirm that the account number of \_\_\_\_\_ (name of account holder), the signature of the authorized signatory and the MICR and IFSC codes of our Branch mentioned above are correct.

PLACE:

DATE:

\_\_\_\_\_  
(Manager / Officer's  
Signature Under Bank stamp)  
Authorisation No. \_\_\_\_\_

Note: This EFT Form is to be submitted duly filled in manually in all fields and duly signed by Authorised Signatory and certified by Banker.