

BHARAT HEAVY ELECTRICALS LIMITED
ESTATE OFFICE BHEL TOWNSHIP, SECTOR-17 NOIDA- 201301



TENDER DOCUMENT

FOR

**PROVIDING AND FIXING OF ALUMINIUM WINDOWS AT
COMMUNITY CENTRE IN BHEL TOWNSHIP, SECTOR- 17,
NOIDA**

NIT No.10: AA: NOI: ADMN: Aluminium-Window: 112: 2016-17
Dated: 22.06.2016

CONTENTS

- 1- Notice Inviting Open Tender
- 2- Techno commercial Bid - Part A
- 3- Price Bid - Part B

LAST DATE FOR SUBMISSION: 07.07.2016 AT 15:00 Hrs.



भारत हेवी इलेक्ट्रिकल्स लिमिटेड
Bharat Heavy Electricals Ltd.

सम्पदा कार्यालय , सेक्टर - 17, नॉएडा - 201301 (यु. पी.) भारत
BHEL Township : Estate Office, Sector-17, Noida-201 301 (UP) INDIA

NOTICE FOR INVITING OPEN TENDER

Sealed tenders are invited in two part bid for the following work in BHEL Township, Sec-17, Noida.

Name of Work : **PROVIDING AND FIXING OF ALUMINIUM WINDOWS AT
COMMUNITY CENTRE IN BHEL TOWNSHIP, SECTOR- 17,
NOIDA**
NIT No. : **10: AA: NOI: ADMN: Aluminium-Window: 112: 2016-17**
Dated: 22.06.2016

Period of Completion : 01 Month.
EMD : NIL

DATE OF SUBMISSION & OPENING OF TENDER

Last date for submission of sealed tender at : **07/07/2016** at **1500 Hrs.**
Estate Office, BHEL Township, Sector-17, Noida
Date of opening the tender : **07/07/2016** at **1515 Hrs.**
Venue for opening of Tender : **Estate Office, BHEL
Township, Sector-17,
Noida**

The Tender Document may be obtained from the office of Engineer (HR-TAX), Estate office, Sector-17, Noida free of cost or may be downloaded from BHEL web site (www.bhel.com) or from CPP portal (<http://eprocure.gov.in>). The sealed tender may be sent either by registered post/ Speed Post/ Courier Services or by hand in the office of Engineer (HR-TAX), between 9.00 AM to 5.30 PM on any working day latest by **07/07/2016** at 3:00 PM. In case of any clarification the bidder can contact undersigned on Tel. No.-0120-6740997 or at e-mail: ujjwal@bhel.in.

(Ujjwal Tomar)
Engineer (HR-TAX)
On behalf of "BHEL"

PART 'A' – TECHNO- COMMERCIAL BID

A. INSTRUCTIONS FOR THE BIDDERS:

1. The offer shall be submitted as per the instructions of tender document. Only one set of tender document duly signed & stamped on each page shall be submitted as detailed further. Tenderer should note specifically that all pages of tender document, including the NIT page for this particular tender shall be submitted by them (after signing/ stamping on each page) as a part of their offer. Price shall not be mentioned by them anywhere in the techno-commercial portion of offer, except in the relevant price bid and submitted in separate sealed envelope. In case of any clarification, bidder may contact this office.
2. Tender documents are also available on BHEL web site (www.bhel.com) & on CPP Portal (<http://eprocure.gov.in/cppp/>) which can be downloaded and used as tender document for submitting the bid.
3. All documents submitted by the Tenderer in his tender may be accompanied with a covering letter giving index interlinking all the documents.
4. No overwriting / correction in tender documents by tenderer shall be allowed. However if correction is unavoidable, the same must be signed.
5. Tender must be submitted in two parts, i.e., (i) Techno-Commercial Bid along with un-price bid (Annexure-E-1) and (ii) Price Bid. The tenderer must submit their tenders in two separate sealed envelopes prominently super scribed as Part – A 'Techno- commercial bid' and Part-B 'Price Bid' along with NIT No. & due date written on each of the envelope. These two separate envelopes shall together be kept in third envelop super scribed with name of Work, NIT No. & due date of opening.
6. Techno-commercial bid should contain all the documents in proof of Pre- qualifying criteria, signed tender document having NIT page, Instructions for tenderer, general conditions, Special Conditions, Contractor's Obligations, un-price bid, all the annexure duly filled & signed by the tenderer.
7. The tenderer shall submit the Bank details along with a cancelled cheque for payment through NEFT/RTGS.
8. Price Bid should contain only the "Part-B, Price Bid Format" after quoting the rates as specified in the Price bid format.
9. Rate shall be quoted for each item inclusive of all taxes but exclusive of service tax which shall be quoted separately in same price bid format. Rates must be quoted in figures as well as in words.
10. **On the date of opening of tender, only Techno-Commercial Bid shall alone be opened.**
11. BHEL reserves the right to accept or reject any or all offers without assigning any reason thereof. Also BHEL shall not entertain any correspondence from bidders in this matter.
12. In case any typing error/other clerical errors is noticed by the tenderer, in the tender documents, the same must be pointed out and got clarified before submission of offer, or else, BHEL's interpretation shall prevail & shall be binding on the tenderer.
13. The Tenderer should accept all terms & conditions of the tender unconditionally. Tenders with deviations from terms and conditions are likely to be rejected.
14. **Tenderers are requested to go through the scope of work, visit the site/location etc. and get fully acquainted with the work place and prevailing working conditions to get all their doubts clarified regarding the above work before submitting the offer. Engineer-in-charge's decision will be full and final in the event of any. Any queries regarding this tender may be clarified from Engineer (HR-TAX), on Telephone No. 0120- 6740997 or e-mail : ujjwal@bhel.in.**
15. The tenderers or their representative may attend the opening of techno-commercial bid (Part-A) and the technically qualified tenderers or their representative may attend the opening of Price bid (Part B), if the so desire. The tenders (both the parts) shall be opened on schedule date & time even if the bidders or their representative are not present.

B. PRE QUALIFYING CRITERIA:

- 1) The bidder should have **PAN No., TIN Registration No., & Service Tax Registration No.**
- 2) The bidder's average annual financial turnover during the last three financial years ending 31st March'15 should be at least Rs **0.44 lakhs**.
- 3) The experience of having successfully completed similar Works (**Similar work shall mean execution of Civil renovation/construction works**) during last 7 years ending on **31.05.2016** should be either of the following:-
 - a) Three similar completed jobs/ services costing not less than Rs. **0.59 Lakhs** each.

Or

- b) Two similar completed jobs/ services costing not less than Rs. **0.74 Lakhs** each.

Or

- c) One similar completed jobs/ services costing not less than Rs. **1.18 Lakhs**.

4) **DOCUMENTS REQUIRED IN SUPPORT OF PRE-QUALIFYING REQUIREMENT:**

- a) **Complete tender document in all respects duly signed & stamped on each and every page as a token of acceptance of all the terms and conditions of tender.**
- b) Self-attested copies of Balance Sheet and Profits & Loss Account statements of last three financial years i.e. FY 2012-13, 2013-14 & 2014-15 (AY 2013-14, 2014-15 & 2015-16) duly verified by CA .
- c) Self-attested copies of acknowledgements of IT return of last three financial years i.e. FY 2012-13, 2013-14 & 2014-15 (AY 2013-14, 2014-15 & 2015-16)
- d) Self-attested copies of Work Orders/ Award letters along with certificates of completion in support of proof of experience for the works executed by the bidders during last 7 years ending on 31.05.2016. BHEL reserves the right to cross check the documents from the issuing department/ company.
- e) Self-attested copies of the **PAN card, Certificate of TIN No and Service Tax Registration No.**
- f) The Bidder must Submit a declaration (enclosed at Annexure –E2), that no case is pending with the police/ court against the proprietor/ firm/ partner or the company (Agency). As well as the bidder has not been suspended / blacklisted by any organization.
- g) No deviation certificate as per Annexure –E3 (enclosed) must be signed and stamped.
- h) Bidder must submit the technical details in the enclosed format (Annexure-E4).
- i) Bidder must submit the bidder's details in the enclosed format (Annexure-E5)
- j) Bidder must submit the check list enclosed at Annexure-E6 after duly filled and signed.

C. GENERAL TERMS & CONDITIONS:-

- 1) Tenders received late /in open condition / not meeting the tender condition / incomplete in any respect are likely to be rejected.
- 2) BHEL will not be responsible for the postal delay under any circumstances for non-receipt of Tenders by due date & time.
- 3) BHEL has the right to reject all or any of the tenders and accept any tender(s) irrespective of its / their being the lowest / highest.
- 4) If any information/ documents submitted by the tenderer are found false/fake at any stage, the tender will be cancelled.
- 5) The offer of the bidders who are on the banned list as also the offer of the bidders, who engage the services of the banned firms, shall be rejected. The list of the banned firms is available on BHEL web site **www.bhel.in**
- 6) The Tenderers are required to quote for the complete scope of work. Tenders for part of the work or incomplete in any respect are liable to be rejected.
- 7) Rates quoted by the bidder will be firm for the contract period or extended period of contract. No price variation and escalation due to increase in labour / material cost will be allowed.
- 8) The rates quoted by the bidder are deemed to be inclusive of all, cost of site clearance and any other incidental works required to complete the work and inclusive of all the taxes but excluding Service Tax. Service Tax shall be quoted extra in the same price bid format.
- 9) The rate should be indicated both in words and figures. All entries in the Tenders must be written in ink or typewritten. Over-writing should be avoided. Corrections, if any, should be attested with signature by the bidder.
- 10) **VALIDITY OF RATES: Validity of rates will be 90 days from the date of opening of the techno-commercial bid.**
- 11) **EVALUTION CRITERIA:** The criteria of evaluation of techno-commercial bids shall be on the basis of documents submitted by the tenderers. BHEL may finalize successful tenderer by either **opening of sealed price bid** or conducting **online Reverse Auction**. Date of opening of sealed Price Bid / conducting of online Reverse Auction will be intimated, by post or e-mail separately to the Tenderers who qualify in the Techno-Commercial bid. The decision of BHEL will be final in this regard. In case of opening of Price Bid, evaluation of bid will be on total cost to 'BHEL'. Evaluation of Price Bid will be done on overall L-1 rate inclusive all including Service tax (on Sl.No.-14(a) or 14 (b) of Price Format). In case of tie between the rates of two or more bidders, the Snap bidding system will be followed to arrive the L-1 bidder.

- 12) **REVERSE AUCTION**: BHEL reserves the right to go for Reverse Auction (RA) instead of opening the sealed envelope price bid, submitted by the bidder. This will be decided after techno-commercial evaluation. All bidders to give their acceptance for participation in RA. Non-acceptance to participate in RA may result in non-consideration of their bids, in case BHEL decides to go for RA. In case BHEL decides to go for Reverse Auction, only those bidders who have given their acceptance to participate in RA will be allowed to participate in the Reverse Auction. Those bidders who have given their acceptance to participate in Reverse Auction will have to necessarily submit online sealed bid in the Reverse Auction. Non-submission of online sealed bid by the bidder will be considered as tampering of the tender process and will invite action by BHEL as per extant guidelines in vogue. The Reverse Auction shall be conducted by a Service Provider (empanelled with BHEL) as per the Business Rules and Terms & Conditions.
- 13) **CORRECTION OF ARITHMETIC ERRORS**: Provided that the bid is substantially responsive, BHEL shall correct arithmetical errors on the following basis:
- If there is a discrepancy between the unit price and the total price that is obtained by multiplying the unit price and quantity, the unit price shall prevail and the total price shall be corrected, unless in the opinion of the BHEL there is an obvious misplacement of the decimal point in the unit price, in which case the total price as quoted shall govern and the unit price shall be corrected.
 - If there is an error in a total corresponding to the addition or subtraction of subtotals, the subtotals shall prevail and the total shall be corrected.
 - If there is a discrepancy between words and figures, the amount in words shall prevail, unless the amount expressed in words is related to an arithmetic error, in which case the amount in figures shall prevail subject to (a) and (b) above.
 - If any bidder does not accept the correction of errors, their bids are liable to be disqualified.
- 14) **CONTRACT AGREEMENT**: A contract agreement shall be signed before the start of work on a non-Judicial stamp paper of Rs 100/-. The contract agreement shall be deemed to have become effective from the forenoon of date of award, and will remain in force for a period 01 Month and then after for maintenance period of 06 months. However, this Agreement may be terminated earlier by BHEL at any time by giving one week notice to the Contractor due to any failure on the part of the contractor in discharging his obligations under the contract, without prejudice to the rights of BHEL to recover any money becoming due under this Agreement. In such a case, the Contractor shall not be entitled to any compensation thereof. The decision of BHEL about the failure on the part of the Contractor shall be final and binding on the Contractor.
- 15) **COMPLETION PERIOD**: The work completion period will be **01 Month from the date of award work** order. The Entire work has to be completed within the contract period failing which the liquidated damages (L.D.) will be imposed.
- 16) **QUANTITY VARIATION**: The quantity of any item mentioned in the BOQ may vary $\pm 15\%$ during execution of work due to site requirement.
- 17) **SUBLETING**: The Contractor shall not sublet, transfer or assign the full work or any part thereof to any other person/company/organization. In case it is found that the work has been sublet, the contract shall be terminated immediately & Security Deposit shall be forfeited.
- 18) **EPF & ESI**: The contractor should have **PF code number & ESI code number** before the start of work. However, in case of not having any or both the documents, the contractor shall arrange & submit the documents before claiming first running bill.
- 19) Accommodation in any manner will not be provided to the workers of the contractor deployed in the execution of work.
- 20) The contractor will be responsible for the quality of the work and it is to be **guaranteed for a period of 06 months from the date of actual completion of contract**.
- 21) Period of guarantee/ maintenance shall mean the period of **06 months** which will be calculated from the date of actual completion of the works certified by the Engineer-in-charge in accordance with conditions of the contract. The period of maintenance shall always be reckoned from the date of completion of the whole of the works as accepted / taken over by Engineer-in-charge.
- 22) **WATER & ELECTRICITY**: Water and electricity shall be supplied to the contractor by BHEL subject to the following conditions:-
- Water & Electricity shall be provided free of cost.
 - Contractor shall make his/ their own arrangement of water/ electricity connection and laying of pipelines/ connection from existing main of source of supply as directed by Engineer Incharge.
 - BHEL do not guaranty to maintain uninterrupted supply of water/ electricity and it will be incumbent on the contractor to make alternative arrangement for proper supply of the same at his/ their own cost

in the event of any break down in the government water/ electricity mains so that the progress of his/ their work is not held up for the want of the same. No claim of damage or refund will be entertained on account of such break down.

23) **STORES AND MATERIALS ON SITE:**

- a) The contractor shall, during the progress of work, provide, erect and maintain at his own expense all necessary temporary work-shops, stores etc. required for the proper and efficient execution of work. The location & size of the store shall have the approval of the Engineer-in-Charge and the contractor shall at all times keep them tidy in a clean and sanitary condition to the entire satisfaction of the Engineer-in-Charge.
- b) All materials for the work are to be deposited by the contractor only in places to be indicated by the Engineer-in-Charge.
- c) The safety & security of the contractor's materials will be the responsibility of contractor himself. BHEL will not provide any compensation due to theft or loss of contractor's materials.
- d) The stores provided by the contractor will not be utilized as the accommodation for the workers or for any other purpose.
- e) Contractor will remove the temporary stores/ structure before claiming the final bill.

24) **PAYMENT TERMS:**

- a) Payment shall be made for the actual executed quantity of work after recording joint measurement on Measurement Book (MB) by Engineer-in-Charge.
- b) Measurement shall be recorded in measurement book (MB) maintained by the Engineer-in-Charge who shall make entries regarding the work executed by the contractor under different items of bill of quantity (BOQ). These entries will be counter-signed by the contractor.
- c) For measurement of work the norms of Indian Standards (IS) as mentioned in CPWD specifications for each items of work shall be followed.
- d) Measurement shall be taken jointly by Engineer-in-Charge or his representative on the part of the BHEL & the contractor.
- e) The contractor shall provide assistance with appliances and other things necessary for measurement without extra charge.
- f) If the contractor / his representative fails to attend when required for measurement, the Engineer-in-Charge shall have power to proceed by himself to take measurements and in that case, these measurements shall be accepted by the contractor as final.
- g) No advance payment or the payment for mobilization of work will be made to the contractor.
- h) No payment shall be made for the work done without the permission of Engineer-in-Charge.
- i) Running bills payment (If demanded by contractor) against the work executed shall be made to the contractor. However only one running bill will be accepted in a month.
- j) The payment of final bill will be made only after obtaining certificate of satisfactory completion of the work by the Engineer-in-Charge, clearance of the site & clearance of all the liabilities on contractor's part. No claim will be entertained after signing the final bill.
- k) Bills raised by the Contractor shall be certified by the official in-charge of BHEL and the payments will be made within three weeks by NEFT/RTGS from the date of receipt of in discrepant bill.
- l) The contractor shall not be entitled to any interest with respect to any money which may be due to him from BHEL.
- m) All payment will be subject to deduction of taxes at source as per rules.
- n) Any tax incurred on purchase of materials by the contractor in respect of this contract shall be treated as included in the charges and BHEL will not entertain any additional claim whatsoever in this respect.
- o) The Service Tax shall be paid as per the quoted rate of Service Tax (at Sl. No.- 12 (a) or 13) of Price Format). No payment of Service Tax will be made if not quoted by the tenderer in the Price Format.

25) **PROGRESS OF WORK AND PENALTY FOR DELAY:**

- a) The project is time bound and works shall have to be carried out at desired pace throughout the execution period so as to complete the work in the stipulated time.
- b) In case there is a delay attributable to contractor in completing the work in 01 Month, L.D. will be imposed @ ½ % (i.e. 0.5 %) per week of delay. However, the total penalty due to delay will be up to maximum 10% of total contract value. LD will be calculated on the total contract value.

- 26) **L.D. FOR BAD QUALITY OF WORK:** If the quality of work is not satisfactory, BHEL reserves the right to impose the LD up to maximum 10% of the contract value.
- 27) Tender LD i.e. for delay as well as quality is to be considered in TOTO i.e. total LD shall be 20% of the contract value.
- 28) Regular meeting (fortnightly or as decided by BHEL) shall be held between BHEL and contractor to review the issues related to progress, penalty, quality and any other aspect.
- 29) The contractor shall have to deploy sufficient number of skilled, semi-skilled and unskilled manpower for quality and timely completion of the work.
- 30) No excuses like hindrance because of extreme weather conditions, non-availability of labour and material etc. will be entertained for not completing the work in time.
- 31) All necessary precautions with respect to safety at site and environmental aspects and their impacts shall have to be taken by the contractor for activities performed by his workers.
- 32) In case of any dispute, the decision taken by BHEL Management will be final and binding on the contractor.
- 33) No party shall be permitted to tender for work in BHEL in which any of their near relatives is an employee connected with the award and execution of the contract. They shall also intimate the names of persons who are working with them in any capacity or subsequently employed by them and who are near relatives of any employee of the BHEL. Any violation of this condition which comes to the Notice of the BHEL after the contract is awarded will entitle the BHEL to treat the contractors as having committed a breach of contract and to exercise all the rights and remedies available to the BHEL on account thereof.
- 34) MSE suppliers can avail the intended benefits only if they submit along with the offer, attested copies of either EM II certificate having deemed validity (five years from the date of issue of acknowledgement in EM II) or valid NSIC certificate or EM II certificate along with attested copy of a CA certificate (Format enclosed at Annexure -1 where deemed validity of EM II certificate of five years has expired) applicable for the relevant financial year (latest audited). Date to be reckoned for determining the deemed validity will be the date of bid opening (Part 1 in case of two part bid). On submission of such document will lead to consideration of their bid at par with other bidders. No benefits shall be applicable for this enquiry if any deficiency in the above required document are not submitted before price bid opening. If the tender is to be submitted through e-procurement portal, then the above required documents are to be uploaded on the portal . documents should be notarized or attested by a Gazetted officer.
- 35) **SECURITY DEPOSIT:**
- a) The security deposit shall be collected from the successful tenderer. The rate of Security Deposit will be as below :
- Upto Rs. 10 lakhs : 10% of work order value**
Above Rs. 10 lakhs & upto Rs. 50 lakhs: Rs. 1 Lakh + 7.5 % of the amount exceeding 10 lakhs
Above Rs. 50 lakhs: Rs 4 lakhs + 5% of amount exceeding Rs 50 lakhs
- The security deposit should be collected before start of work by the contractor.
- b) Security deposit may be furnished in any one of the following forms:
- i) Cash (as permissible under the Income Tax Act)
 - ii) Pay order / demand draft in favour of BHEL.
 - iii) Local cheques of schedule banks, subject to realization.
 - iv) Securities available from Post Offices such as National Saving Certificates, Kisan Vikas Patras etc. (Certificate should be held in the name of the contractor furnishing the security and duly pledged in favour of BHEL and discharged on the back).
 - v) Bank Guarantee from Schedule Banks/ Public Financial Institutions as defined in the Companies Act. The Bank Guarantee format should have the approval of BHEL.
 - vi) Fixed deposit Receipt issued by Schedule Banks/ Public Financial Institutions as defined in the Companies Act. The FDR should be in the name of the contractor, A/C BHEL, duly discharged on the back.
 - vii) Security deposit can also be recovered at the rate of 10% from the running bills. However in such cases at least 50% of the Security Deposit should be deposited before start of the work and balance 50% may be recovered from the running bills.
 - viii) The Security Deposit shall not carry any interest.

(Acceptance of Security Deposit against Sl.No. (iv) & (vi) above will be subject to hypothecation or endorsement on the documents in favour of BHEL. However, BHEL will not be liable or responsible in any manner for the collection of interest or renewal of the documents or in any other matter connected therewith).

- c) The security deposit will be released only after completion of Guarantee/ Maintenance period of **six months** from the date of actual completion of work.
 - d) Failure to pay the security deposit shall be treated as failure to discharge the duties under the contract and shall result in cancellation of the contract and the contractor shall be liable to compensate BHEL for any losses incurred by BHEL. BHEL reserves the right to appropriate any part / whole of the amount of the security deposit without prejudice to other claims against the contractor for losses suffered by BHEL due to failures on the part of the contractor, due to termination of contract or contractor becoming disqualified because of liquidation / insolvency. The decision of BHEL in respect of such losses, damages, charges, expenses or costs, shall be final and binding to the contractor.
- 36) **TERMINATION OF CONTRACT ON DEATH:** Without prejudice to any of the rights or remedies under this contract, if the contractor dies, the accepting officer shall have the option of terminating the contract without compensation to the contractor's survivors.
- 37) **RECOVERY FROM CONTRACTOR:** Whenever under the contract, any sum of money shall be recoverable from or payable by the contractor, the same may be deducted from any sum then due or which at any time thereafter may become due to the contractor under the contract or under any other contract with BHEL or from his security deposit, or the contractor shall pay the claim on demand without any terms & conditions.
- 38) **POST TECHNICAL AUDIT OF WORK AND BILLS:** BHEL reserves the right to carry out a post payment audit and technical examination of the work and final bill including all supporting vouchers, abstracts etc. and to enforce recovery of any sums becoming due as a result thereof in the manner provided into the proceeding sub-paragraph provided however, that no such recovery shall be enforced after three years of passing the final bill.
- 39) **ARBITRATION / CONCILIATION:** In the event of any dispute arising between the parties hereafter referred as BHEL and Contractor in respect of or connected with this contract, General & Special terms & conditions of tender, then the same shall be referred to Arbitration and Arbitrator will be nominated by the Head of Administration of BHEL Corp. Office, New Delhi, whose decision shall be final and binding on both the parties. However, any differences or doubt pertaining to meaning/ interpretation of any phrase word used in terms or in the schedule of services, their nature and manner of rendering of such services shall be the excepted matter and be referred to the Head of Administration of BHEL Corp. Office, New Delhi, whose decision shall be the final and binding. The provisions of Arbitration and Conciliation Act, 1996 or any statutory modification and re-enactment thereof will apply to such arbitration provided however, in all matters the venue of proceedings will be Delhi and only Delhi or appropriate Courts will have jurisdiction over the same.
- 40) **RISK CLAUSE:** BHEL reserves the right to terminate the contract due to any failure on the part of the Contractor in discharging his obligations under the contract or in the event of his becoming insolvent or going into liquidation. The decision of the BHEL about the failure on the part of the Contractor shall be final and binding on the Contractor. In the event of any failure on the part of the Contractor, BHEL shall have the right without any prejudice to get the work done through any other alternate agency at the risk and cost of Contractor. The additional cost including loss, if any incurred by BHEL will be recovered from the Contractor.

D. SPECIAL TERMS & CONDITIONS RELATED TO THE SUBJECT WORK:

- 1) The subject work shall be carried out up to the satisfaction of Engineer-in-charge.
- 2) The work will be carried out as per BOQ enclosed and as per latest CPWD Specifications for all the works. In case of any doubt regarding the specification and its quality of work, Engineer in Charge's clarification and decision will be final and binding on the contractor.
- 3) All the materials shall be arranged by the contractor. No materials shall be issued from BHEL.
- 4) All tools and tackles required for proper completion of work shall be arranged by contractor.
- 5) After completion of the work at the site, contractor will remove all unwanted material/ rubbish from the site with no extra claim.
- 6) Proper curing of all the cement work as per specifications shall be done by contractor on no extra claim.
- 7) The Typical drawings of the subject work are enclosed at Annexure-E7. It may be noted that these are rough drawings for indicative purpose only.

- 8) **CARE OF BUILDINGS:** Care shall be taken by the contractor to avoid damage to the existing buildings during execution of work. He shall be responsible for repairing all the damages and restoring the same to their original finish at his cost. He shall also remove at his costs all unwanted and waste materials arising out of his work from the site.
- 9) **QUALITY OF MATERIALS:** All materials supplied by the contractor shall be new. They shall be such design, size and materials as given in BOQ and to satisfactorily function.
- 10) **INSPECTION OF MATERIALS:** All the materials delivered by the contractor at site shall be inspected and verified by Engineer-in-charge before use.
- 11) **WORKMANSHIP:** Good workmanship is an essential requirement to be complied with. The entire work shall conform to sound engineering practice. In case of bad workmanship re-work will be done by the contractor on no extra claim
- 12) **SUPERVISION OF WORK:** The contractor will deploy sufficient numbers of Supervisors/ Engineers of appropriate qualification and experience to ensure proper execution of work. They will carry out instructions of Engineer-in-charge and other senior officers of BHEL during the progress of work.
- 13) **GUARANTEE / MAINTENANCE PERIOD:** The work shall be guaranteed against any inferior quality/ workmanship. The guarantee / maintenance period will be for a period of **6 months** from the date of actual completion of contract. The full Security Deposit (SD) amount shall be retained for the guarantee/ maintenance period and it shall be released after satisfactory carrying out all rectification/ repaired works as informed by the Engineer-in-charge. In case of not attending any rectification/ repairing work by the contractor, the rectification work will be carried out by any outside agency and recovery will be done from the contractor.

E. CONTRACTOR'S OBLIGATION:

- 1) The Bidder along with its associate/collaborators/sub-contractors/sub-vendors/consultants/service providers shall strictly adhere to BHEL Fraud Prevention Policy displayed on BHEL website <http://www.bhel.com> and shall immediately bring to the notice of BHEL Management about any fraud or suspected fraud as soon as it comes to their notice.
- 2) Contractor shall supervise the Work allotted to him to be carried out by his workforce. The contractor shall visit the site every day to ensure the work is carried out in fast pace for completion within schedule time.
- 3) Contractor to ensure that the workforce deployed in the premises of BHEL are physically and mentally fit and do not have any criminal record. Such employees should possess requisite skill, proficiency, qualification, experience etc.
- 4) The workforce deployed by the contractor shall be hail and healthy and should not be suffering from any communicable diseases.
- 5) Contractor to accept full and exclusive liability for the wages, Allowances, PF, ESI, for the workforce deployed by the contractor and other obligation referred under the law at present and any future taxes imposed by the Government / Local Bodies.
- 6) BHEL will have no liability whatsoever concerning the persons deployed by the contractor for the purpose. The contractor shall keep the Company indemnified against all losses or damages or liability arising out of or imposed in the course of employment of persons by the contractor.
- 7) Statutory requirement of the local authority / State Govt. / Central Govt. shall be responsibility of the contractor.
- 8) The contractor will be solely responsible for any unlawful act of their workforce while on duty. In case of theft or loss of Company's property take place due to the negligence or carelessness of workforce, the contractor will be responsible and shall make good of the same.
- 9) The Contractor shall duly comply with all acts, laws, or other statutory rules, regulations, bye-laws applicable or which might be applicable to with regard to the performance of the contract included herein or concerning this Agreement but not limited to Minimum Wages Act- 1948, Contract Labour (Regulation & Abolition) Act, 1970, Industrial Dispute Act, 1947, Workmen's Compensation Act 1923, Employees' State Insurance Act 1948 (to the extent as may be applicable, if any), Employees' Provident Fund and Misc. Provisions Act, 1952 and the amendments made thereafter to these Acts / Laws and from time to time take such steps as may be deemed necessary in this regard. The Contractor shall keep the Company Indemnified against all penalties, claims and liabilities of every kind under or for any violation of such acts, laws or regulations etc. by him or his workers.

- 10) In case, while on duty and during the course of engagement in work premises of the Company under this Agreement, if any of the Contractor's workforce suffers with any injury / indisposition due to accident or other natural calamities, the Contractor shall ensure that immediate and adequate medical aid viz., first -aid and subsequent treatment facilities are provided to the person(s) concerned free of cost without fail. In addition, the Contractor shall also be liable for meeting with statutory liabilities like ESI etc. in respect to his workers.
- 11) The Contractor shall be fully responsible for the timely payment of wages, Allowances, Bonus or any other benefits payable under the aforesaid Acts, Laws and regulations to the workforce engaged by him at the work premises of the Company. Contractor shall also be fully responsible for timely deposit of PF and ESI with the appropriate authority including submission of return of PF & ESI and issue of PF slip issued by the PF Authority. The Company shall not be responsible for these payments or any other liability on this account. The Contractor shall also indemnify and compensate the Company for any liability incurred by the Company, if any, including costs incurred thereon. In that event the nominated officer of the Company shall be entitled to recover the amount so paid, from the contractor, including forfeiture of the Security Deposit; and, if the sum so payable and / the Security Deposit is less than the Company's claim, it shall be lawful for the Company to recover the balance amount as a debt from the Contractor.
- 12) The Contractor shall indemnify and compensate the Company, if the Company as Principal Employer under the Contract Labour (Regulation and Abolition) Act, 1970 becomes liable to assume any liability towards the workforce engaged by the contractor. In that event, the provisions relating to recover as provided in relevant clauses of the said Act shall be applicable in Toto.
- 13) The Contractor shall be held responsible for any damage / loss to the work premises /or the properties of the Company (i.e. missing or broken fittings, equipments, furniture etc. and loss of such things) caused due to the negligence of his work force and shall have to replace the same at his own cost. The decision of the Engineer-in-charge shall be final and binding on the Contractor.
- 14) The contractor shall hand over a copy of all legal and statutory documents and records to BHEL for fulfilling any future requirement with the statutory authority.
- 15) The contractor shall abide by all the rules / regulations / status imposed by the Govt. or other concerned authorities. The contractor will be responsible for workmen's compensation & other requirements of local Municipalities / Govt. or any other law regulating bodies
- 16) Contractor to maintain appropriate records of his employees deployed to carry out the job (s).
- 17) Contractor to get all his employees insured against all type of risks at his own cost.
- 18) Contractor to ensure that all precautions are taken for safety of his employees and equipments.
- 19) In the event of termination of contract for any reason whatsoever, the contractor shall withdraw all his employees from the site of BHEL. In case contractor decides to terminate services of his employees, he should settle all terminal dues including retrenchment compensation.
- 20) The successful tenderer must comply to all statutory labour law regulations applicable to this contract like minimum wages act, timely payment of wages etc. including taking of insurance cover etc. for workers employed for this contract. Any obligation on account of the above will be the liability of the successful tenderer.
- 21) In case of any objection from any statutory / local authority, the contractor has to liaison with them for smooth progress of work.
- 22) The Contractor shall ensure proper conduct and behavior of the workforce engaged by him on the site and shall remove with immediate effect, the engagement of such person(s) who does/do not conduct himself / themselves properly or misbehave(s) with the residents of township or the staff of Estate office.

(Ujjwal Tomar)
Engineer (HR-TAX)
On behalf of "BHEL"

UN-PRICE BID

**Name of Work : PROVIDING AND FIXING OF ALUMINIUM WINDOWS AT
COMMUNITY CENTRE IN BHEL TOWNSHIP, SECTOR- 17,
NOIDA**

NIT No. : 10: AA: NOI: ADMN: Aluminium-Window: 112: 2016-17
Dated: 22.06.2016

S. No.	Description of Item	Unit	Qty.	Rate	Amount
1	Dismantling doors, windows and clerestory window (steel or wood) including chowkhata, architrave, holdfasts etc, complete and stacking within 50 metres lead : Of area 3 sq.metres and below	each	8.00	XXXX	XXXXXX
2	Repairs to plaster of thickness 12 mm to 20 mm in patches of area 2.5 sq. meters and under, including cutting the patch in proper shape, raking out joints and preparing and plastering the surface of the walls complete, including disposal of rubbish to the dumping ground within 50 metres lead ,With cement mortar 1:4 (Icement: 4 coarse sand)	sqm	30.00	XXXX	XXXXXX
3	Providing and fixing aluminium work for doors, windows, ventilators and partitions with extruded built up standard tubular sections/ appropriate Z sections and other sections of approved make conforming to IS: 733 and IS: 1285, fixing with dash fasteners of required dia and size, including necessary filling up the gaps at junctions, i.e. at top, bottom and sides with required EPDM rubber/ neoprene gasket etc. Aluminium sections shall be smooth, rust free, straight, mitred and jointed mechanically wherever required including cleat angle, Aluminium snap beading for glazing / paneling, C.P. brass / stainless steel screws, all complete as per architectural drawings and the directions of Engineer-in-charge. (Glazing, paneling and dash fasteners to be paid for separately) For fixed portion Anodised aluminium (anodised transparent or dyed to required shade according to IS: 1868, Minimum anodic coating of grade AC 15)	kg	55.00	XXXX	XXXXXX
4	Providing and fixing aluminium work for doors, windows, ventilators and partitions with extruded built up standard tubular sections/ appropriate Z sections and other sections of approved make conforming to IS: 733 and IS: 1285, fixing with dash fasteners of required dia and size, including necessary filling up the gaps at junctions, i.e. at top, bottom and sides with required EPDM rubber/ neoprene gasket etc. Aluminium sections shall be smooth, rust free, straight, mitred and jointed mechanically wherever required including cleat angle, Aluminium snap beading for glazing / paneling, C.P. brass / stainless steel screws, all complete as per architectural drawings and the directions of Engineer-in-charge. (Glazing, paneling and dash fasteners to be paid for separately) For shutters of doors, windows & ventilators including providing and fixing hinges/ pivots and making provision for fixing of fittings wherever required including the cost of EPDM rubber / neoprene gasket required (Fittings shall be paid for separately) Anodised aluminium (anodised transparent or dyed to required shade according to IS: 1868, Minimum anodic coating of grade AC 15)	kg	150.00	XXXX	XXXXXX

5	Providing and fixing glazing in aluminium door, window, ventilator shutters and partitions etc. with EPDM rubber / neoprene gasket etc. complete as per the architectural drawings and the directions of engineer-in-charge (Cost of aluminium snap beading shall be paid in basic item) With float glass panes of 4.0 mm thickness	sqm	12.00	XXXX	XXXXXX
6	Providing and fixing fly proof galvanized M.S. wire gauge to windows and clerestory windows using wire gauge with average width of aperture 1.4 mm in both directions with wire of dia 0.63 mm all complete. With 12 mm mild steel U beading	sqm	12.00	XXXX	XXXXXX
7	Providing and fixing anodised aluminium grill (anodised transparent or dyed to required shade according to IS: 1868 with minimum anodic coating of grade AC 15) of approved design/pattern, with approved standard section and fixed to the existing window frame with C.P. brass/ stainless steel screws @ 200 mm centre to centre, including cutting the grill to proper opening size for fixing and operation of handles and fixing approved anodised aluminium standard section around the opening, all complete as per requirement and direction of Engineer-in-charge. (Only weight of grill to be measured for payment).	kg	45.00	XXXX	XXXXXX
8	Providing and fixing aluminium tower bolts, ISI marked, anodised (anodic coating not less than grade AC 10 as per IS : 1868) transparent or dyed to required colour or shade, with necessary screws etc. complete, 100x10 mm	each	60.00	XXXX	XXXXXX
9	Providing and fixing aluminium handles, ISI marked, anodised (anodic coating not less than grade AC 10 as per IS : 1868) transparent or dyed to required colour or shade, with necessary screws etc. complete, 100 mm	each	60.00	XXXX	XXXXXX
10	Providing and fixing aluminium casement stays, ISI marked, anodised (anodic coating not less than grade AC 10 as per IS : 1868) transparent or dyed to required colour and shade, with necessary screws etc. complete.	each	30.00	XXXX	XXXXXX
11	Total Amount Rs.				XXXXXX
12 (a)	In case, as per the current status the party (service provider) is an Individual, HUF, or partnership firm including AOP	Service Tax (on.....% of total amount of SI No. 11) to be payable by party (.....%) (Rs)			XXXXXX
12 (b)		Service Tax (on.....% of total amount of SI No. 11) to be payable by BHEL (.....%) (Rs)			XXXXXX
13	In case, as per the current status the party is a Private or Public limited Company	Service Tax (on.....% of total amount of SI No. 11) to be payable by party (.....%) (Rs)			XXXXXX
14 (a)	Total Amount inclusive of Service Tax	In case of Individual, HUF, or partnership firm including AOP (Total of 11+12a+12b) (Rs)			XXXXXX
14 (b)		In case of Private or Public limited Company (Total of 11+13) (Rs)			XXXXXX

(Signature & seal of the contractor)

DECLARATION

I / We, do hereby declare that there is no case with the Police/Court/Regulatory authorities against the proprietor/firm/partner. Also I/We have not been suspended / delisted / blacklisted by any other Govt. Ministry / Department/Public Sector Undertaking/ Autonomous Body/Financial institution/Court. We also certify that either our firm or any of the partners are not involved in any scam or disciplinary proceedings settled or pending adjudication

(Signature & seal of the contractor)

Place:

Date:

ESTATE OFFICE: BHEL TOWNSHIP: NOIDA

**Name of Work : PROVIDING AND FIXING OF ALUMINIUM WINDOWS AT
COMMUNITY CENTRE IN BHEL TOWNSHIP, SECTOR- 17,
NOIDA**

**NIT No. : 10: AA: NOI: ADMN: Aluminium-Window: 112: 2016-17
Dated: 22.06.2016**

No Deviation Certificate

Notwithstanding anything mentioned in our bid, we hereby accept all the terms and conditions of the above tender and there is no deviation in the terms & conditions of tender. We confirm that the offer submitted by is confirming to all the terms and conditions mentioned in the tender document. We hereby undertake and confirm that we have understood the scope of services properly and shall carry out the job as mentioned in this tender.

(Signature & seal of the contractor)

TECHNICAL DETAILS

TURNOVER (F.Y.)	Rs. Lacs		
	2012-13	2013-14	2014-15

EXPERIENCE	No. of Work	Value	Customer's Name

SIMILAR WORKS	Nature of Works	No. of works	Value	Customer's Name

EPF Registration number	
ESI Registration number	
PAN Card No.	
Service Tax No.	
TIN No.	

Income Tax Return (F.Y.)	2012-13	2013-14	2014-15
Details of manpower			

(Signature & seal of the contractor)

BIDDER'S DETAILS

Name of the Contractor /Party/ Firm	
Name of Representative	
Postal Address	
Phone/ Landline Nos.	
Mobile Nos.	
Fax No.	
E-Mail Address	
Web Site Address (If Any)	
Bank details for payment through NEFT/RTGS	Name of Bank: Branch: Account No.: IFSC No.: MICR No.:

Note: Submit a canceled cheque for verification of above bank details.

(Signature & seal of the contractor)

**CHECK-LIST (TECHNICAL BID)
SUMMARY OF COMPLIANCE TO REQUIREMENT OF TENDER**

Sl. No.	Description of requirement	Yes/ No/NA	Page No.
1	Details of work experience, satisfactory work performance certificates.		
2	Copies of the Balance sheet and Profit & Loss account statement of last three financial years i.e. FY 2012-13, 2013-14 & 2014-15 (AY 2013-14, 2014-15 & 2015-16) duly verified by CA		
3	Acknowledgement of IT returns (ITR) of last three financial years i.e. FY 2012-13, 2013-14 & 2014-15 (AY 2013-14, 2014-15 & 2015-16)		
4	Copy of the PAN card.		
5	Copy of TIN No. registration certificate		
6	Copy of Service Tax registration certificate		
7	Copy of EPF Registration and details		
8	Copy of ESI Registration and details		
9	Declaration enclosed at Annexure – E2		
10	No deviation certificate enclosed at Annexure – E3		
11	Technical details as per Annexure-E4		
12	Bidder's detail as per Annexure- E5		
13	All the pages of tender document have been signed		
14	Sealed envelope of price bid submitted.		

(Signature & seal of the contractor)

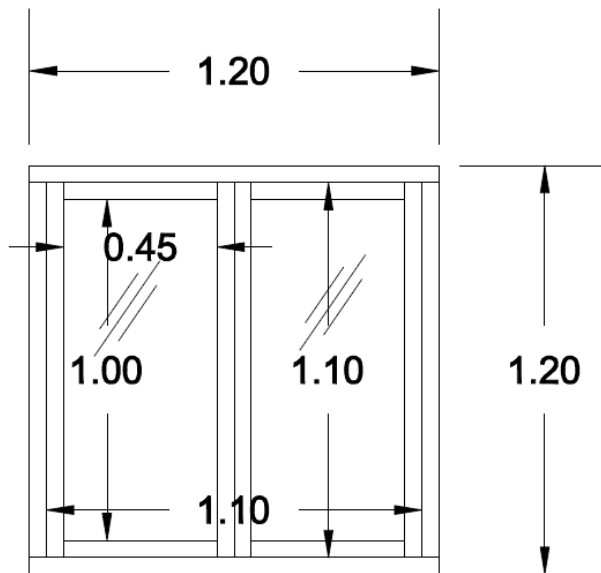

WINDOW LOBY AREA

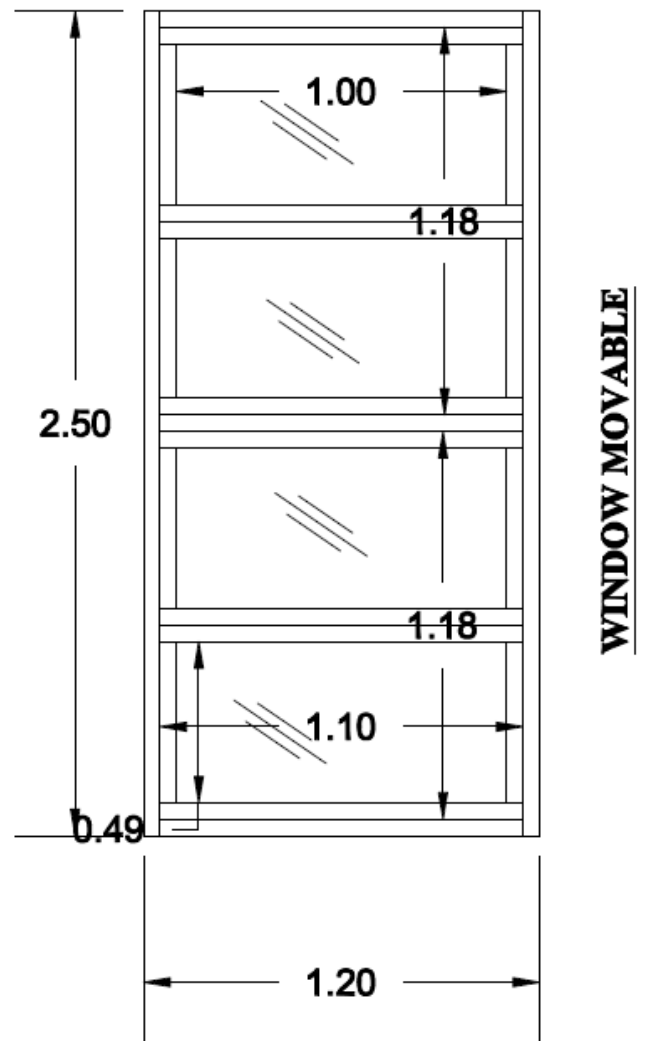

WINDOW MOVABLE

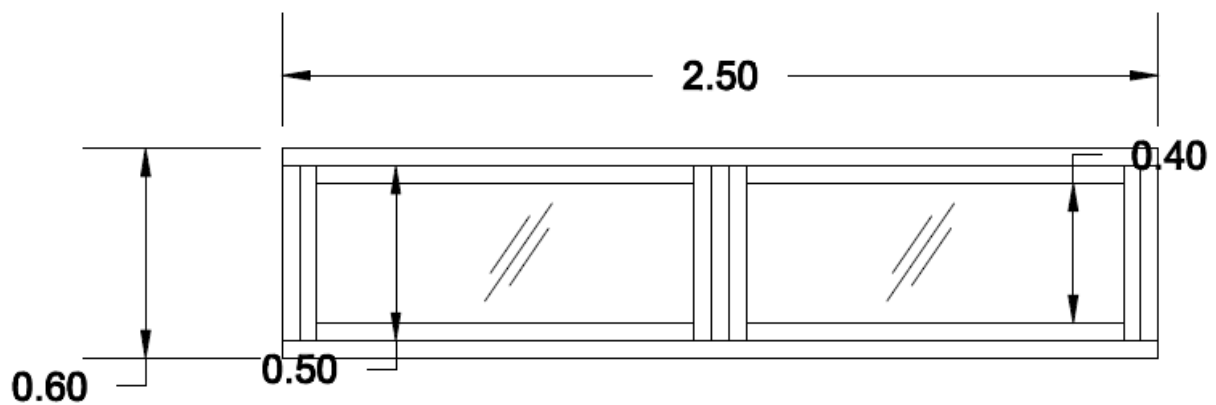

WINDOW FIXED